

1985

Thunderbird





Donald E. Petersen
President

Ford Motor Company
The American Road
Dearborn, Michigan 48121



Dear New Car Buyer:

Quality is Job 1 at Ford Motor Company. This isn't just a phrase. It's a commitment to total quality.

Total quality begins with the design and engineering of our cars and continues through the life of the product. We plan them with a vision of the customer — of you — sitting behind the wheel of a new car.

Total quality will be apparent to you through functional performance, overall vehicle integrity, the "look and feel" of materials, satisfying aesthetics, safety, serviceability and cost of ownership.

Total quality requires continuous improvement in everything we do. Every employee at Ford Motor Company is involved in the process of meeting your needs and expectations.

I think the 1985 Thunderbird is an excellent example of the quality I'm talking about. A driver's car, its exterior styling is not only distinctive, but functional, contributing to handling capability and fuel economy. And, for the performance-oriented driver, Turbo Coupe is an exhilarating road car.

I invite you to look over our new 1985 Ford cars in your dealer's showroom. Test drive them on the road. When you do, I think you'll understand all that's involved in the total quality concept at Ford Motor Company.

Donald E. Petersen
President
Ford Motor Company

Thunderbird for 1985



Thunderbird, perhaps more than other cars, begs to be driven. Because the way it looks improves the way it drives. And the way it drives, with its gas-filled shocks and MacPherson front suspension, is something that should be experienced.

Contents

| | |
|--|-------|
| Quality and Workmanship | 4-5 |
| Ride and Handling | 6-7 |
| Power and Efficiency | 8-9 |
| Thunderbird Environment | 10-11 |
| Thunderbird | 14 |
| Thunderbird élan. | 15 |
| FILA Thunderbird | 16 |
| Thunderbird Turbo Coupe | 17 |
| Features, Options, Colors and Trims | 18-19 |
| Safety Features | 20 |
| Owner Information | 21 |

Front and back covers: standard Thunderbird (some equipment shown may be optional)

In the standard **Thunderbird**, design technology creates an aerodynamically efficient shape — a driver's car with 5-passenger comfort and an impressive list of standard equipment.

Thunderbird élan offers a luxuriously appointed interior compartment as well as a number of standard convenience items. Pure Thunderbird, élan provides those appreciated extras.

The **FILA Thunderbird** includes many of the comfort and convenience features of the élan, and adds styling touches inspired by the world-famous sportswear. **FILA** is a very personal Thunderbird.

Thunderbird Turbo Coupe is performance. The 2.3 liter turbocharged engine is the heart of this world-class touring car which offers sophisticated performance equipment and a high level of standard features.

A word about this catalog: Some of the equipment shown or described throughout the catalog is available at extra cost.

Quality and Workmanship

Ford Motor Company is committed to building cars that meet the high quality standards expected by those who drive them.

Every aspect of the car's design has a purpose, whether it be aerodynamic efficiency or interior comfort.

Engineering systems — the engine and suspension, for example — are

manufactured and assembled under strict quality controls.

The hood, doors, decklid, moldings — everything has stringent fit tolerances. The paint finish is smooth and lustrous.

Behind the quality of every Ford car are the dedicated people who produce it.

Design and engineering, where quality begins.

Quality demands that before a car can be built right, it must first be designed and engineered right.



Today, engineers can measure with amazing accuracy how a car responds to actual on-road conditions long before it is built. It's done with simulations of full-scale vehicles and individual components in action on computer screens.

Vehicles can be driven around pylons at various speeds, climb steep grades, run over potholes, just as they would be in real testing at a proving ground. The computer displays in close detail the intricate movements of the suspension and other systems. They're evaluated to high standards of performance, redesigned and retested if necessary.

Even with this advanced technology, however, the art of automotive design and engineering remains in the hands of designers and engineers. The computer is there to assist them.

Withstanding stress. The ultimate test of a car's quality.

Drivers expect their cars to function properly in everyday use. So Ford cars are road-tested over hundreds of thousands of miles, are subjected to extreme stress and load conditions over paved and unpaved surfaces, up and down steep grades, through corrosive salt baths. They run the full course of demanding acceleration, cornering and braking maneuvers.

But even before these road tests, Ford engineers put prototype cars through numerous laboratory tests. The Electrodynamic Actuator, for example, drives a car continuously under a variety of road and weather conditions. One objective is to eliminate squeaks and rattles caused by bumps and jolts and the effects of hot and cold temperatures.



Computers, robots and lasers in manufacturing and assembly.

Monitoring engine performance, checking electrical systems for accuracy, helping ensure smooth paint applications for finish quality — these are some of the vital roles that computers play in the assembly of Ford cars.

Ford places great importance also on robotics to achieve high quality in fit, finish and function. Robots are programmed to provide consistency and control to an extraordinary degree. They can do the 2,000 welds on a car's body quickly, completely, with the precision the blueprints demand.

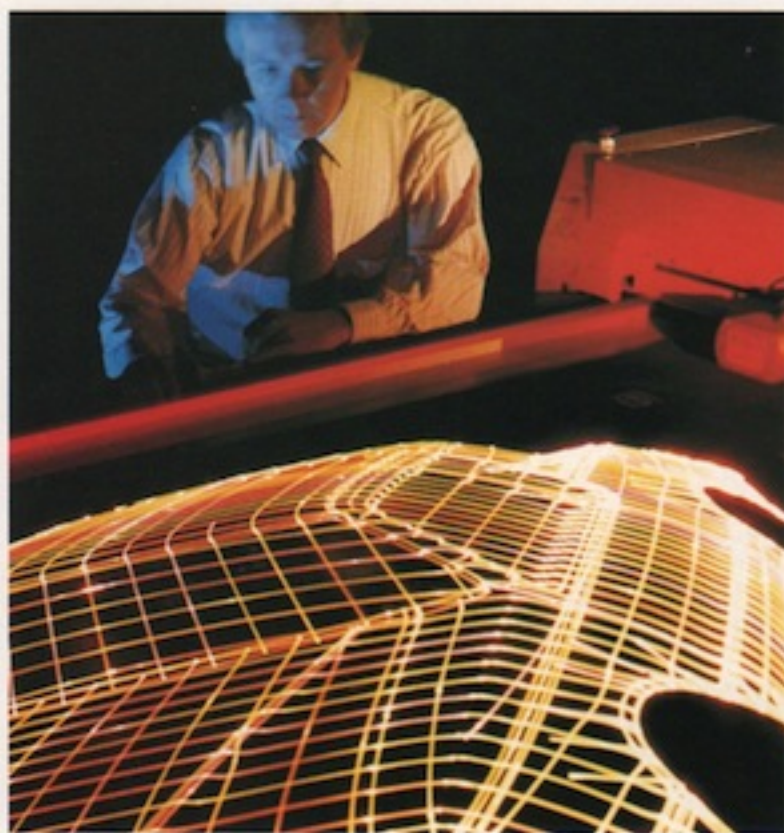

The laser, another advanced-technology tool, helps improve quality by providing accurate measurement of everything from engine castings and door margins to nuts and bolts and fasteners.

Special quality steps: Corrosion protection.

Ford takes tough measures to protect its cars against the damaging effects of corrosion. Galvanized steel is used for important underbody and structural parts. Pre-coated steel, featuring corrosion inhibitors, is also used in major body panels. Special treatments are applied to selected areas of the body structure.

Ingenuity and teamwork. The essential ingredients of high quality.

At Ford, striving for high quality is a team effort. This is nowhere more evident than in the hundreds of recommendations for quality improvements submitted every year by more than 1,100 Employee Involvement (EI) groups in 65 Ford plants across America.

In addition to the EI groups, there are "durability-reliability" teams specially trained to carry out extensive quality control programs before production begins, and "quality" teams whose primary responsibility is quality improvement after production gets under way.



With all the technology and resources at work producing quality products, the people at Ford realize that quality is a never-ending preoccupation. This attitude is essential to Ford's total commitment to quality.



Left: standard Thunderbird shown with optional wide bodyside moldings, dual bodyside and decklid accent stripes, hood stripes, dual electric remote-control mirrors, rear window defroster, automatic dimming rearview mirror, illuminated entry system, alloy wheels, P215/70 HR 14 BSW performance tires, and special handling package.

Ride and Handling

Modified MacPherson front suspension

The MacPherson design is recognized for the quality of its ride characteristics and its contribution to vehicle handling. In Thunderbird, it's combined with a four-bar link rear suspension. The suspension geometry provides good overall stability, steering and handling.

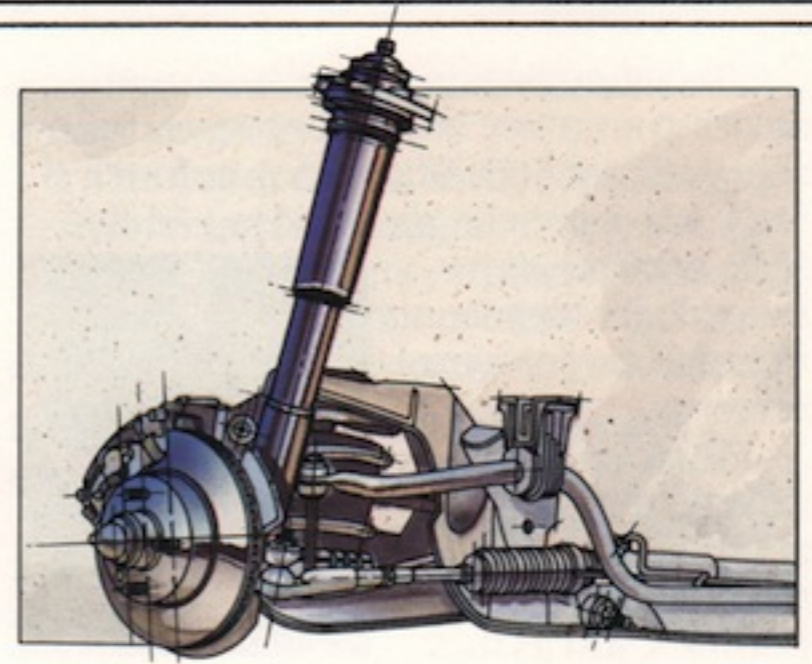

At left: Modified MacPherson front suspension incorporates gas-filled shock absorbers.

Gas-filled struts and shock absorbers

Thunderbird's struts/shock absorbers contain a low-pressure charge of nitrogen gas which suppresses foaming of the hydraulic fluid due to rapid bumps or similar agitation. This means the ride is smooth under normal circumstances, yet firm enough for rough conditions.

Power rack and pinion steering

Rack and pinion steering is synonymous with performance and crisp handling. That's why it was chosen for Thunderbird, with the added convenience of power assist and variable ratio. Variable ratio means a stable steering feel at highway speeds with fewer turns of the wheel required for turning and parking maneuvers. These three elements — rack and pinion, power assist, and variable ratio — combine to form a steering system that's right in all driving situations. The Turbo Coupe, which puts a bigger premium on handling, has a 15:1 non-variable ratio.

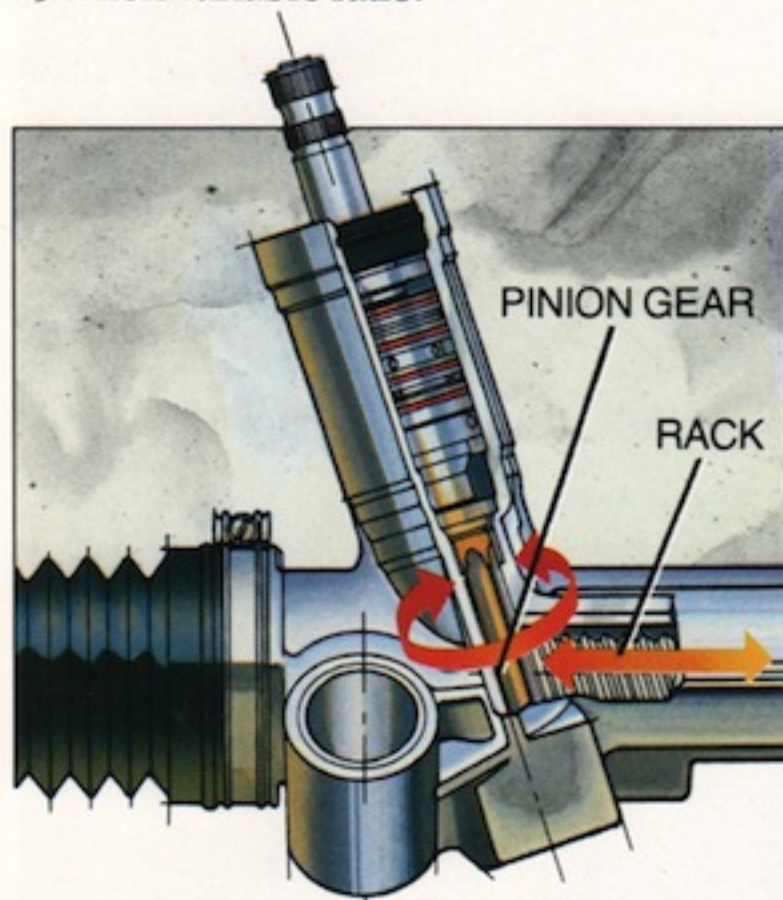

Rack and pinion steering: At the end of the steering column is a "pinion gear" which engages a "rack" of gear teeth linked to the steering arms. The responsiveness and precision of rack and pinion steering are directly related to its simple, low-friction design.

The Turbo Coupe Quadra-Shock rear suspension: four shock absorbers for improved handling

The Turbo Coupe's rear suspension system uses four shock absorbers. A pair of gas-filled shock absorbers are mounted vertically between the outer ends of the rear axle and the car's rear frame. These shocks soften and smooth the rear wheels'

Left: Thunderbird Turbo Coupe shown with optional cornering lamps and pivoting front vent windows.

vertical travel caused by bumps, pavement breaks, potholes, etc.

Another pair of freon-filled, gas-bag axle dampers are mounted horizontally between the ends of the rear axle and

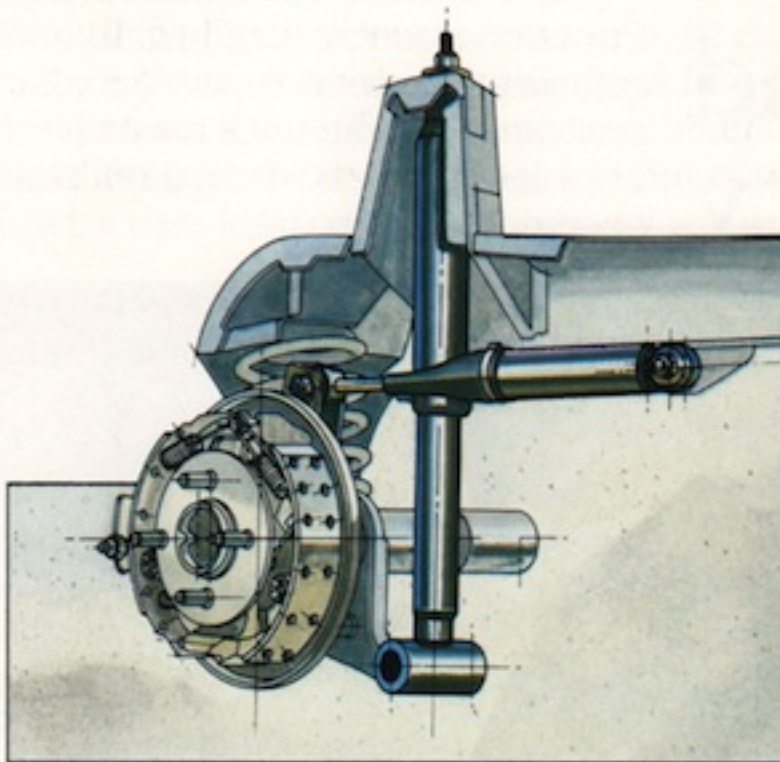

An extra set of horizontally mounted rear freon-filled, gas-bag axle dampers means additional stability through turns for Turbo Coupe.

the frame to control the axle's fore-and-aft movement. They also help keep the axle in the proper location when cornering.

Turbo Coupe performance tires

The handling capabilities of Turbo Coupe are greatly enhanced by VR speed-rated, steel-belted radial-ply Goodyear Eagle performance tires. The P225/60 VR 15 tires, mounted on 15" x 7" aluminum wheels, feature a new Unidirectional "Gatorback" tread design derived from Goodyear's Formula One racing rain tire. The new tread design and performance rubber compounds provide excellent traction and road-holding capability on both wet and dry pavement.

The handling benefit of airflow management

Thunderbird uses the air to help hold the road firmly. Through careful fine-tuning of selected design areas, airflow is directed to reduce front and rear lift for directional stability and cornering agility. And the smooth lines contribute to reduced wind noise.



Power and Efficiency

EEC-IV: one of the world's most advanced automotive computers

All Thunderbird engines benefit from a computer called EEC-IV, a fourth-generation, state-of-the-art, micro-processor-based engine control system capable of processing thousands of operations per second.

EEC-IV adjusts the air/fuel mixture and ignition timing for quick cold starts. On the road, it constantly senses what the car is being asked to do, then balances the air/fuel mixture and timing for optimum power, response and fuel efficiency.



Standard 3.8 liter V-6 with electronic fuel injection (EFI)

Electronic fuel injection provides several advantages over a conventional carburetor. The major advantage is a more efficient use of fuel. EFI offers improved overall operation. Smooth running. Easier starting in hot and cold temperatures.

The V-6 powerplant features refinements in intake valve and combustion chamber design to incorporate high-swirl action, helping to further improve fuel economy. It also produces excellent torque at part throttle for good performance off the line. Contributing to its smooth operation is a specially designed camshaft which provides an equal 120-degree firing interval between all cylinders.

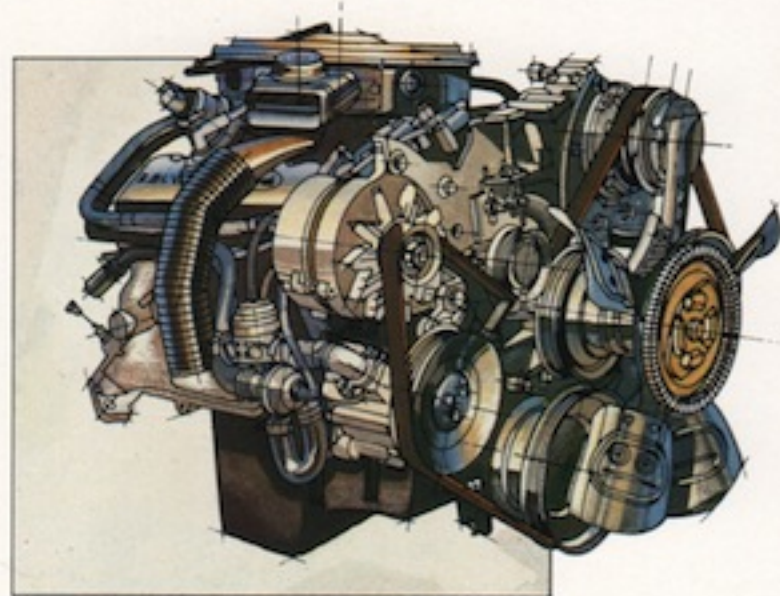

Thunderbird transmissions

The 3.8 liter V-6 is teamed with an automatic transmission designed for efficiency. It has a locking torque converter which, unlike conventional automatics, provides a mechanical connection between engine and transmission in all three forward gears. This results in considerably less torque converter slip for more efficient use of the engine's power.

If you choose, you may specify the optional Automatic Overdrive (AOD) transmission and 5.0 liter V-8 engine with electronic fuel injection.* AOD automatically shifts into an overdrive fourth gear when the vehicle exceeds 45 mph and the driver eases up on the accelerator pedal. In overdrive fourth, engine speed is reduced by one-third. The result is improved highway fuel economy. The standard transmission in Turbo Coupe is a 5-speed manual, carefully calibrated so there is a proper gear for any turn, any

Left: Thunderbird shown with optional wide bodyside moldings, dual bodyside and decklid accent stripes, rear window defroster, dual electric remote-control mirrors, illuminated entry system, automatic dimming rearview mirror, and alloy wheels.

straightaway. The SelectShift automatic is available for Turbo Coupe as well.

**AOD is standard with FIA and required with the 5.0 liter V-8 engine.*

Airflow management

Fuel economy is enhanced by Thunderbird's aerodynamic shape. A .35 C_D helps it slip through the air, requiring less power from the engine to overcome resistance. Because the engine isn't working as hard, it uses less fuel.



Turbocharging: efficient power

Turbocharging is the means to combine power and efficiency in one engine. It has two major benefits. Under normal driving circumstances, the turbo remains efficiently at idle, contributing to fuel savings. But when a surge of power is required, pressing on the accelerator brings the turbo into action for instantaneous response.

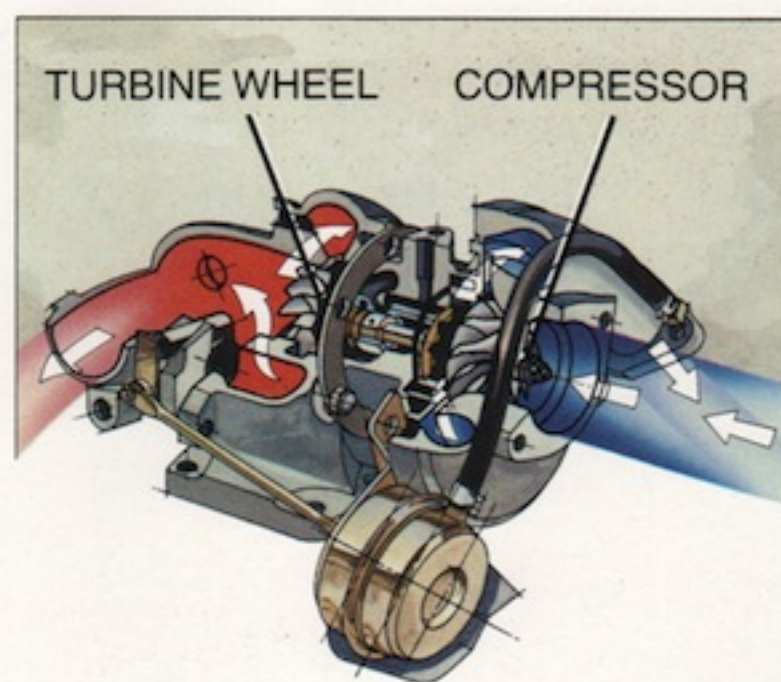

Turbocharging: Hot exhaust gases (red) turn the turbine wheel to power the compressor. Outside ambient air (blue) enters the compressor and is blown through the induction system to the combustion chambers.

Turbo Coupe's powerplant

The Turbo Coupe's engine is an efficient, high-performance cross-flow head, overhead cam four-cylinder. It displaces 2.3 liters and has a compression ratio of 8.0 to 1. It has five main bearings, forged aluminum pistons, high-temperature alloy valves, oil cooler and intake manifold. The port-type fuel injection system, fed by an electric fuel pump, injects a precisely

controlled amount of fuel directly into the intake port for each cylinder. A "blow through" turbocharger is positioned upstream from the injectors and throttle plate. Unlike "draw through" arrangements, a "blow through" system minimizes lag time to deliver crisp, quick throttle response. Around 4,500 RPM, the engine achieves a projected 155 horsepower with the standard 5-speed manual transmission (based on SAE standard J 1349). Power output higher when premium unleaded fuel is used.

Thunderbird powerteams

| Engine | Transmission | Final Drive Ratio | | |
|------------|---------------------|-------------------|---------------|--------|
| | | 49 States | High Altitude | Calif. |
| 3.8L V-6 | SelectShift auto. | 2.73 | 2.73 | 2.73 |
| 3.8L V-6 | Automatic Overdrive | 3.27 | 3.45 | 3.27 |
| 2.3L Turbo | 5-Speed manual | 3.45 | 3.45 | 3.45 |
| 2.3L Turbo | SelectShift auto. | 3.45 | 3.45 | 3.45 |
| 5.0L V-8 | Automatic Overdrive | 3.08 | 2.73 | 3.08 |

Gas mileage

1985 EPA mileage estimates were not available at the time this catalog was approved for printing. As soon as EPA figures are released, your Ford Dealer will be among the first to receive this information and will be happy to pass it along to you.

Thunderbird Environment

Thunderbird ergonomics

Correct interior design involves the application of the science of ergonomics: the close relationship of the driver to the car.

In Thunderbird, applied ergonomics creates an environment with sensible, convenient placement of seats, controls, instruments and lights. For example, turn

signals, windshield wiper/washer controls and headlamp dimmer are mounted on the steering column at the driver's fingertips.

Thunderbird's individually reclining split bench front seats are body contoured for comfortable back and thigh support. They have deep foam cushions with firm but flexible spring support. The rear seat has a center seat belt which allows for 5-passenger seating. Articulated seats, standard in Turbo Coupe and **FILA**, reward the demanding driver. The

under-thigh support adjusts. The side-thigh support adjusts. The seat back angle adjusts. The power lumbar support is infinitely adjustable and the head restraints adjust four ways.

Thunderbird command center

The Thunderbird instrument panel features an electronic LCD speedometer and combination odometer/trip odometer. Fuel and temperature gauges are analog type, and warning lights include "fasten seat belts," "high beam" and

"brake." (Optional electronic instrument cluster shown below, described on page 18.)

Other command center highlights include a service interval reminder, speed warning, positive shutoff air registers, side window demisters and automatic parking brake release.

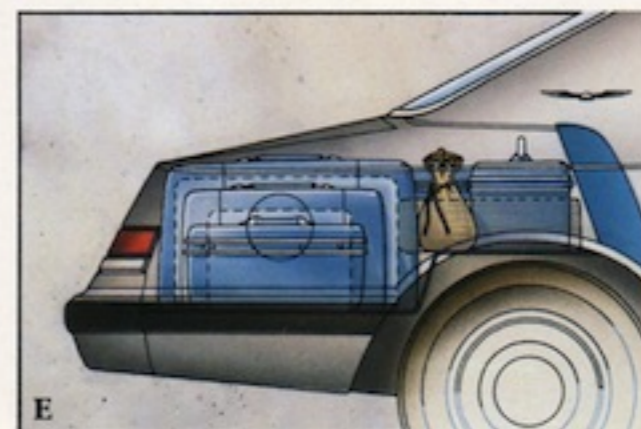

(A) Optional electronic digital clock (B) Thunderbird elan instrument panel with Electronic Instrument Cluster option (other options may also be shown) (C) Electronic Instrument Cluster detail (metric calibration shown) (D) Console (some equipment shown may be optional). (E) Thunderbird's surprisingly spacious deep-well trunk.

Left: Thunderbird elan interior (some equipment shown may be optional).



Thunderbird shown with optional wide bodyside moldings, dual bodyside and decklid accent stripes, rear window defroster, dual electric remote-control mirrors, illuminated entry system, and alloy wheels.

Thunderbird



A driver's car. Powered by a 3.8 liter V-6 engine and the efficient* SelectShift automatic transmission. Thunderbird's ride and handling are enhanced by gas-filled shocks and struts, P205/70R14 all-season tires, variable ratio power rack and pinion steering and power front disc/rear drum brakes.



Thunderbird shown with optional wide bodyside moldings, dual bodyside and decklid accent stripes, rear window defroster and dual electric remote-control mirrors.



The aerodynamic shape contributes to both fuel efficiency* and vehicle handling.

The 5-passenger interior compartment features reclining split bench seats, an electronic/analog instrument cluster and many color-keyed components. Convenience items like trip odometer, self-regulating illuminated quartz electric clock, lockable glove box and carpeted package tray are also standard. Entertainment is provided by an AM/FM stereo radio.** The large deep-well trunk has a low liftover height for easy loading and unloading.

*See Gas mileage, page 9. **May be deleted for credit.

Thunderbird élan

The hallmark of Thunderbird élan is its luxurious interior. The split bench seats feature luxurious cloth trim (ultrasoft leather trim is optional) and 4-way adjustable headrests. Cloth inserts* are in the door panels and the coved area of the quarter trim panels. Door panels include



courtesy lights, and a console-mounted switch operates additional quarter trim panel courtesy lights. There are illuminated visor mirrors as well.

Thick 24-oz. carpet covers the passenger compartment floor, and 9-oz. carpet is used extensively in the luggage compartment. There's a convenient folding center armrest for the rear passengers. See page 19 for the long list of additional élan convenience features and luxury cues.

**Vinyl inserts with optional leather trim.*



Thunderbird élan shown with optional hood stripes, cornering lamps, rear window defroster, pivoting front vent windows, illuminated entry system, automatic dimming rearview mirror, and styled road wheels.



Thunderbird

The **FILA** was inspired by the world-famous quality sportswear. The unique Pastel Charcoal exterior paint is enhanced, inside and out, with special color-coordinated components, striping,



FILA Thunderbird shown with optional pivoting front vent windows. Available in Pastel Charcoal over Dark Charcoal (featured above) or in solid Black, Bright Red or Medium Charcoal Clearcoat Metallic.



fabric, and the distinctive **FILA** logo. The interior features the élan's luxury appointments (page 15). Articulated seats in oxford grey suede-style cloth are also available in oxford white leather.

Comfort and convenience items include a 6-way power driver's seat, Power Lock Group, illuminated entry system, and more. See page 19 for complete **FILA** equipment.



Thunderbird Turbo Coupe

The Turbo Coupe features high performance, distinctive styling and a long list of convenience items. The 2.3 liter turbo-charged engine is linked to a close-ratio 5-speed manual transmission with a smooth, short-throw shifter. 15" x 7" alumi-



num wheels are standard, and they're matched with P225/60VR15 BSW Goodyear performance tires.

Inside, a performance instrument cluster contains an analog speedometer, tachometer, turbo boost gauge and fuel, temperature, oil pressure and ampere gauges. There's a soft-feel sport steering wheel, articulated sport seats and luxury level door trim panels with courtesy lights. See page 19 for a complete list of Turbo Coupe features and convenience items.



Thunderbird Turbo Coupe shown with optional rear window defroster and cornering lamps.

Thunderbird Features and Options

Rapid-Spec Packages — the best way to buy Thunderbird options.

When you select your new Thunderbird, be sure to ask your Ford Dealer about Rapid-Spec Packages. They benefit you in these two important ways: (1) they simplify the ordering procedure, and (2) they can save you money. Many packages include Value Option Discounts. These can represent savings over the manufacturer's suggested retail price totals of the same options if purchased separately. Your dealer has complete details.

The electronic instrument cluster

The electronic instrument cluster option features an electronic LCD speedometer and odometer/trip odometer with service interval reminder and speed warning. Other electronic gauges: tachometer with graphic readout; temperature, oil pressure, amperes and fuel. Fuel level is also displayed digitally with "low fuel" flasher warning. Shown on page 11.

Graphic equalizer

Thunderbird's optional graphic equalizer features 7-band tone control for precise sound mixing over a wide frequency range (D, right).

Illustrated options

(A) Electronic AM/FM stereo search radio with cassette tape and Dolby® noise reduction system
(B) Tripminder® computer. Travel data at your fingertips: average trip speed, distance covered per gallon of fuel used, instantaneous fuel economy, total fuel used. Also the date, time, and elapsed trip time and distance. English or metric readout
(C) Heated driver and passenger seat (see your dealer for availability)
(D) Graphic equalizer (see above)
(E) Rear window defroster
(F) Keyless entry system
(G) Speed control
(H) Pivoting front vent windows
(I) "Tot-Guard" (dealer accessory)
(J) Alloy wheels
(K) Locking wire-style wheel covers
(L) Styled road wheels
(M) Luxury wheel covers (standard)

A word about Ford options

Some of the equipment shown or described throughout the catalog is available at extra cost.

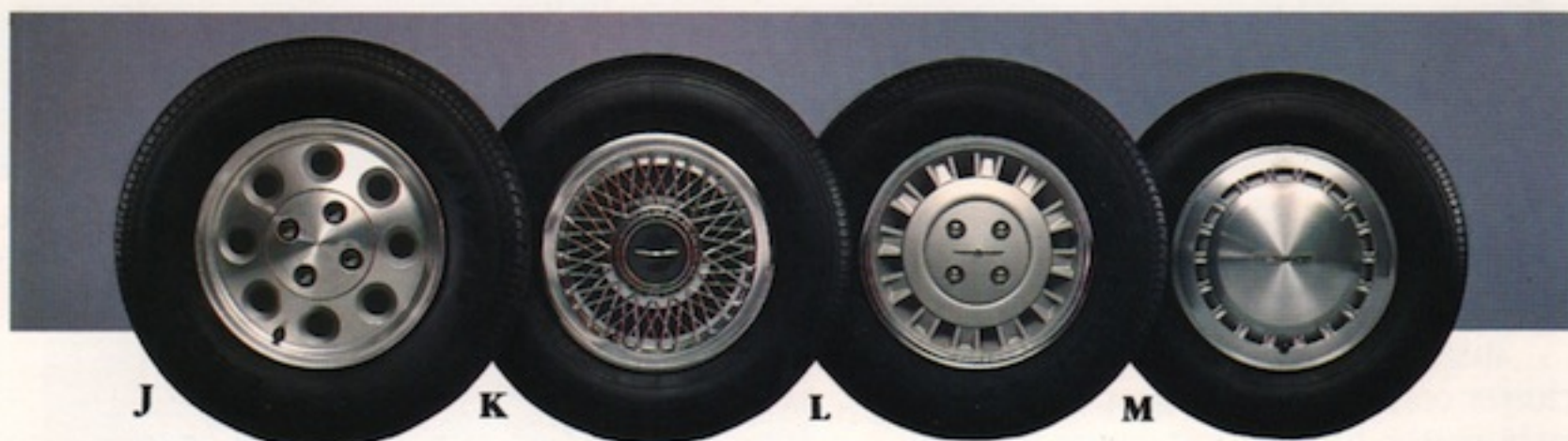
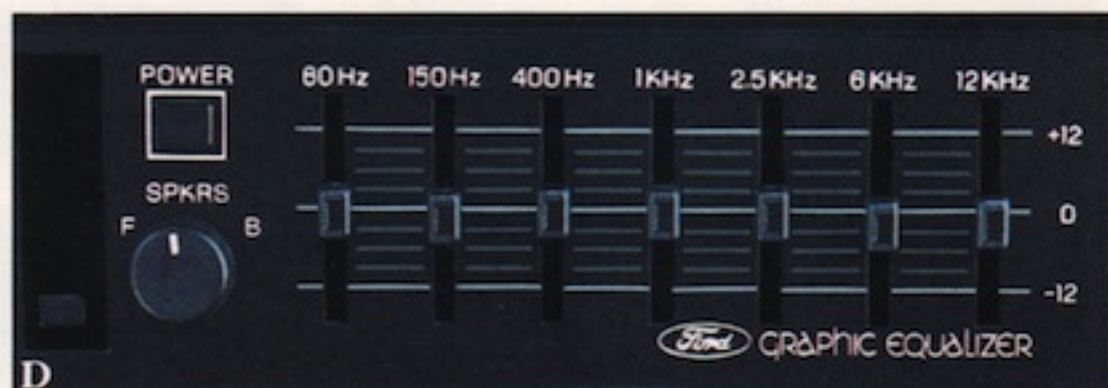
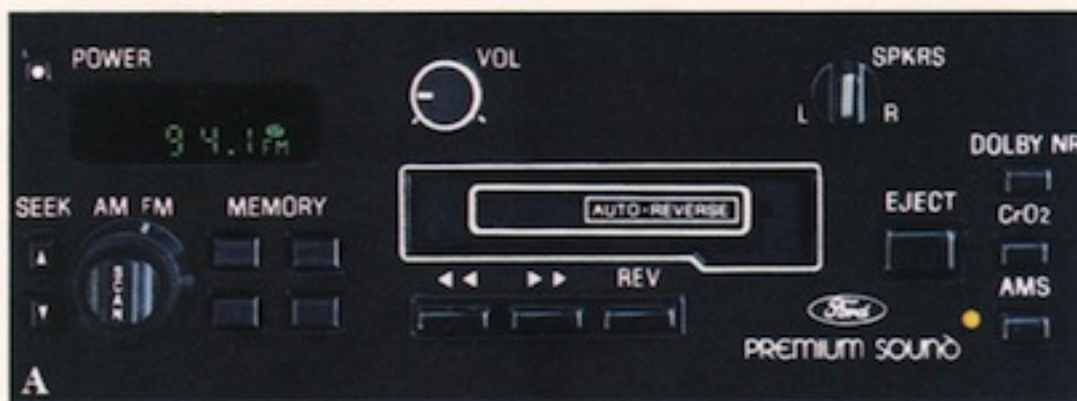

Explanatory Notes for Features and Options

*See page 16 for special **FILA** equipment.

S = Standard O = Optional NA = Not Available

(1) Requires 5.0 liter V-8 engine. (2) Turbo Coupe features 15:1 non-variable ratio. (3) Alloy wheels in a different color are available. (4) Available in Power Lock Group only. (5) Includes dual beam map light, instrument panel courtesy lights and engine compartment light. (6) See your dealer for availability. (7) Includes power door locks. Remote-control electric decklid release and remote locking fuel door are in glove box. (8) See your dealer for information on available tires. (9) Includes heavy-duty rear springs, heavy-duty front strut and rear shock absorber valving, rear stabilizer bar, and larger diameter front stabilizer bar.

Safety Features

A commitment to safety

Safety, like quality, begins as an attitude, a way of thinking that's fundamental in shaping a vehicle's structure and components from the drawing board to assembly.

Occupant safety

Ford commits enormous resources every year to the development and testing of all car lines and their occupant protection features.

Body structures are carefully designed from the start with passenger safety as a primary concern. After they are validated for theoretical soundness, structures are assembled into prototype vehicles and subjected to exhaustive crash testing.

Operating safety

This term applies to a vehicle's ability, with the aid of the driver, to avoid an accident.

Ford cars are engineered to do their part — provide suspension and steering systems designed for control, as well as a brake system designed to provide fast stopping action and fade resistance.

Of course, it's up to the driver to make the best use of the vehicle's accident-avoidance equipment. This involves driving defensively, reacting in time, and such seemingly small things as properly regulating the ventilation system (to help the driver stay alert).

5-mile-an-hour bumpers

Bumpers on Thunderbird are designed to protect lamps, cooling system, exhaust and other body components in the event of a minor impact. While some manufacturers have replaced the 5-mile-an-hour bumper system with a 2½-mile-an-hour system, Ford offers you the protection of 5-mile-an-hour bumpers, front and rear.

Get it together — buckle up.

Ford Motor Company strongly encourages all passengers to use their safety belts.

In all Ford cars, outboard front seat lap and shoulder belts have automatic retractors and comfort regulators. Outboard rear seat positions also have lap belts with retractors.

Ford urges the use of child and infant restraints, even in states where they are not required by law. Ford's easy-to-install Tot-



Guard (for children 20 to 50 pounds) and Infant Carrier (for children up to 20 pounds) are available at all Ford Dealers. If a child restraint requires a top-tether, Ford cars provide for attachment of an anchor at each rear outboard seating position.

Thunderbird Lifeguard Design Safety Features

Vehicle operation

- Safety rim wheels and load-rated tires
- Split service hydraulic brake system with warning light
- Corrosion-resistant brake lines
- Flash-to-pass headlamps
- Turn indicator lever with lane-changing signal feature
- Hazard warning flasher
- Backup lights
- Side marker lights
- Parking lights coupled with headlamps
- Two-speed or variable speed windshield wipers
- Windshield washers
- Outside rearview mirror, driver's side
- Glare-reduced instrument panel, windshield wiper arms and windshield pillars
- Uniform transmission shift quadrant with safety starting switch (on all cars equipped with automatic transmissions)
- Continuously variable control illumination intensity (instrument cluster lighting)
- Safety hood latch system
- Function-rated windshield defroster system

Occupant protection

- Safety-designed front end structure
- Safety-designed roof structure
- Steel guard rails in side doors
- Double yoke safety door latches and safety hinges
- Integral lap and shoulder belts with automatic retractors for occupants of front seats
- Positive seat belt fastening reminder warning light and chime for the driver's seat
- Lap belts for rear seating positions with retractors for rear outboard occupants
- Energy-absorbing steering column and steering wheel
- Energy-absorbing armrests and door handles
- Energy-absorbing instrument panel with padding for right front passenger
- Energy-absorbing sun visors
- Energy-absorbing front seat back tops
- Self-locking front seat back latches
- Head restraints for front outboard occupants
- Safety glove box latch
- Inside yieldaway rearview mirror
- Impact-absorbing laminated safety glass windshield
- Flame-resistant interior materials
- Safety-designed coat hooks
- Safety-designed radio control knobs and push buttons

Anti-theft

- Locking steering column with key warning chime reminder (with "Park" interlock or push button for key release)
- Visible vehicle identification number
- Single key with anti-theft design for door entry and ignition

Damage resistance

- Impact-resistant front and rear bumper systems

Owner Information

Measurements

| | |
|---------------|--------------|
| Wheelbase | 104.0" |
| Length | 197.6" |
| Height | 53.2" |
| Width | 71.1" |
| Front tread | 58.1" |
| Rear tread | 58.5" |
| Trunk space | 14.6 cu. ft. |
| Fuel capacity | 20.6 gal.* |
| Curb weight | 3,090 lb.** |
| Passengers | 5 |

*18.0 gallons with Turbo Coupe.
**Standard vehicle. Turbo Coupe: 3,103 lb.



As part of Ford Motor Company's commitment to your total satisfaction, participating Ford Dealers offer the Free Lifetime Service Guarantee. They stand behind their work, in writing, for as long as you own your car. This guarantee covers virtually every repair you pay for after your new vehicle warranty expires. Now when you pay for a covered repair once, you never have to pay for the same repair again. Ever. The dealer who did the work will fix it free. Free parts. Free labor.

While it doesn't cover routine maintenance parts, belts, hoses, sheet metal or upholstery, this limited warranty does cover thousands of parts in normal use.

No other car company's dealers, foreign or domestic, offer this kind of security. Nobody.

See your participating Ford Dealer for details.



Ford Motor Company's optional Extended Service Plan covers major components on new Ford cars and light trucks for longer than the vehicle's basic warranty. The cost is so moderate for the protection you get that it could pay for itself the first time you need it. Your Ford Dealer will be happy to detail the plan for you. Available on all cars and most light trucks, it is

honored by more than 6,100 Ford and Lincoln-Mercury dealers nationwide and in Canada.



QUALITY REPLACEMENT PARTS FROM FORD

Genuine Ford and Motorcraft original equipment replacement parts are precision engineered and manufactured to Ford specifications to deliver top-level performance in all Ford-built cars and trucks. The Ford and Motorcraft brand names are your best assurance of quality and long-term satisfaction because these replacement parts meet the same high standards as those installed in production, and at Ford, "Quality is Job 1."

Scheduled maintenance

Ford wants to reduce the frequency and cost of scheduled maintenance on its cars to an absolute minimum. Here are some examples of scheduled maintenance intervals for the 1985 Thunderbird. For complete maintenance recommendations, refer to the Thunderbird Owner Guide.

| | |
|----------------------------|--|
| Engine oil change | each 7,500 miles* |
| Spark plug change | each 30,000 miles** |
| Air filter replacement | each 30,000 miles |
| Engine coolant replacement | each 30,000 miles (50,000 miles or 3 years with 2.3L Turbo) or 3 years |

*5,000 miles with Turbo Coupe.
**15,000 miles with Turbo Coupe.

The commitment to quality by Ford and its dealers can save you money on repairs, too.

In addition to the Lifetime Service Guarantee, the Extended Service Plan and Ford and Motorcraft original equipment parts already described, Ford and Ford Dealers are working in other ways to save you money on repairs and help ensure your satisfaction.

Nationwide dealer network ready to assist you

Should your Ford car or truck need repair while you're traveling or away from home, the nearest servicing dealer can be located simply by calling one of the toll-free numbers listed under "Ford-paid repair programs."

Specialized tools and equipment

The latest in diagnostic and service equipment designed especially for use in the repair of Ford Motor Company products is available. This equipment helps the technician make the repair properly so you won't have to come back a second time.

Continued service technician training

Dealership technicians are continuously updated on the latest techniques and procedures to help them keep your Ford car or truck running at its best.

Ford-paid repair programs after the warranty period

Sometimes Ford offers adjustment programs to pay all or part of the cost of certain repairs. These programs are intended to assist owners and are in addition to the warranty or to required recalls. Ask Ford or your dealer about such programs relating to your Ford or Lincoln-Mercury vehicle.

To get copies of any adjustment program for your vehicle or the vehicle of interest to you: Call Ford toll-free at 1-800-241-3673. Alaska/Hawaii call 1-800-241-3711 and in Georgia call 1-800-282-0959.

Or write Ford at:

Ford Customer Information System
Post Office Box 95427
Atlanta, Georgia 30347

We'll need your name and address; year, make and model vehicle, as well as engine size; and whether you have a manual or automatic transmission.

Technical service bulletins

All vehicles need repairs during their lifetime. Sometimes Ford issues technical service bulletins (TSBs) and easy-to-read explanations describing unusual engine or transmission conditions which may lead to costly repairs, the recommended repairs, and new repair procedures. Often a repair now can prevent a more serious repair later. Ask Ford or your dealer for any such TSBs and explanations relating to your Ford or Lincoln-Mercury vehicle.

To get copies of these technical service bulletins and explanations for your vehicle or the vehicle of interest to you: Call Ford toll-free at 1-800-241-3673. Alaska/Hawaii call 1-800-241-3711 and in Georgia call 1-800-282-0959.

Or write Ford at:

Ford Customer Information System
Post Office Box 95427
Atlanta, Georgia 30347

We'll need your name and address; year, make and model vehicle, as well as engine size; and whether you have a manual or automatic transmission.

Options availability

Options shown or described in this catalog are available at extra cost and may be offered only in combination with other options or subject to additional ordering requirements or limitations.

Product changes

Ford Division reserves the right to change product specifications at any time without incurring obligations.

"Ask your Ford Dealer"

Following publication of this catalog, certain changes in standard equipment, options, prices and the like, or product delays, may have occurred which would not be included in these pages. Your Ford Dealer is your best source for up-to-date information.

THUNDERBIRD FEATURES

| ENGINEERING | Thunderbird | élan | FILA* | Turbo Coupe |
|---|-------------|-------|-------|-------------|
| 3.8 liter 2V V-6 engine with EFI | S | S | S | NA |
| 2.3 liter OHC turbocharged engine with EFI | NA | NA | NA | S |
| SelectShift automatic transmission with locking torque converter | S | S | NA | 0 |
| Automatic Overdrive transmission | 0(1) | 0(1) | S | NA |
| 5-speed manual overdrive transmission with tunnel-mounted shift and leather-wrapped knob | NA | NA | NA | S |
| Variable-ratio power rack and pinion steering | S | S | S | S(2) |
| Power front disc/rear drum brakes | S | S | S | S |
| Electronic voltage regulator | S | S | S | S |
| Modified MacPherson strut front suspension with gas-filled struts | S | S | S | S |
| Four-bar link rear suspension with gas-filled shocks (Turbo Coupe includes unique suspension) | S | S | S | S |
| Full analog instrumentation, including tachometer with boost and overboost lights | NA | NA | NA | S |
| Traction-Lok axle | 0 | 0 | 0 | S |
| P205/70R14 all-season BSW tires | S | S | S | NA |
| P225/60VR15 BSW performance tires | NA | NA | NA | S |
| Automatic parking brake release | 0 | S | S | NA |
| EXTERIOR | | | | |
| Concealed drip moldings | S | S | S | S |
| Halogen headlamps | S | S | S | S |
| Dual electric remote-control mirrors | 0 | S | S | S |
| Wide bodyside moldings | 0 | S | S | S |
| Cornering lamps | 0 | 0 | S | 0 |
| Bodyside and decklid accent stripes | 0 | S | NA | NA |
| Unique front fascia with air dam and Marchal® fog lamps | NA | NA | NA | S |
| Luxury wheel covers | S | S | NA | NA |
| 14" aluminum wheels | NA(3) | NA(3) | S | NA |
| 15" aluminum wheels | NA | NA | NA | S |
| INTERIOR | | | | |
| Reclining split bench seats with cloth seating surfaces and console | S | S | NA | NA |
| Articulated seats | 0 | 0 | S | S |
| Rear seat center folding armrest | NA | S | S | S |
| Performance instrumentation | NA | NA | NA | S |
| 16-oz. color-keyed cut-pile carpeting | S | NA | NA | NA |
| Luxury door and quarter trim panels | NA | S | S | S |
| Quarter panel courtesy lights | NA | S | S | S |
| Luxury steering wheel with center horn blow | S | S | NA | NA |
| Leather-wrapped steering wheel | 0 | 0 | S | NA |
| *Soft feel* sport steering wheel | NA | NA | NA | S |
| Quartz electric clock | S | NA | NA | NA |
| Electronic digital clock | 0 | S | S | S |
| AM/FM stereo radio (may be deleted for credit) | S | NA | NA | S |
| AM/FM stereo radio with cassette tape player | 0 | S | NA | 0 |
| Electronic AM/FM stereo search radio with cassette player, Dolby® noise reduction system | 0 | 0 | S | 0 |
| Premium sound system and power lock group | 0 | 0 | S | 0 |
| Interval windshield wipers and power windows | 0 | S | S | S |
| 6-way power driver's seat | 0 | 0 | S | 0 |
| Tinted glass, complete | 0 | S | S | S |
| Speed control | 0 | 0 | S | 0 |
| Tilt steering wheel | 0 | 0 | S | 0 |
| Autolamp System with automatic dimming | 0 | 0 | S | 0 |
| Illuminated Entry System | 0 | 0 | S | 0 |
| Diagnostic warning lights and Light Group | 0 | S | S | S |
| Remote locking fuel door | 0(4) | S | S | S |

THUNDERBIRD OPTIONS

| ENTERTAINMENT SYSTEMS | Thunderbird | élan | FILA* | Turbo Coupe |
|--|-------------|------|-------|-------------|
| AM/FM stereo radio with cassette tape player | 0 | S | NA | 0 |
| Electronic AM/FM stereo search radio with cassette tape player and Dolby® noise reduction system | 0 | 0 | S | 0 |
| Premium Sound System | 0 | 0 | S | 0 |
| Graphic equalizer | 0 | 0 | 0 | 0 |
| APPEARANCE | | | | |
| Wide bodyside moldings | 0 | S | S | S |
| Dual bodyside and decklid accent stripes | 0 | S | NA | NA |
| Hood stripes | 0 | 0 | NA | NA |
| Two-Tone paint with tape stripes | 0 | 0 | NA | NA |
| Clearcoat metallic paint | 0 | 0 | 0 | 0 |
| ASSISTS/ELECTRONIC DRIVING AIDS | | | | |
| Autolamp System | 0 | 0 | S | 0 |
| Diagnostic warning lights | 0 | S | S | S |
| Electronic Instrument Cluster (page 18) | 0 | 0 | 0 | NA |
| Tripfinder® computer | 0 | 0 | 0 | 0 |
| COMFORT AND CONVENIENCE | | | | |
| Cornering lamps | 0 | 0 | S | 0 |
| Rear window defroster | 0 | 0 | 0 | 0 |
| Dual electric remote-control mirrors | 0 | S | S | S |
| Pivoting front vent windows | 0 | 0 | 0 | 0 |
| Keyless Entry System (includes Illuminated Entry System) | 0 | 0 | 0 | 0 |
| Illuminated Entry System | 0 | 0 | S | 0 |
| Interval windshield wipers | 0 | S | S | S |
| Flip-up/open-air roof | 0 | 0 | 0 | 0 |
| Air conditioning, electronic climate control | 0 | 0 | 0 | 0 |
| Air conditioning, manual control | 0 | 0 | 0 | 0 |
| Automatic parking brake release | 0 | S | S | NA |
| Electronic digital clock | 0 | S | S | S |
| Tinted glass, complete | 0 | S | S | S |
| Light Group (5) | 0 | S | S | S |
| Speed control | 0 | 0 | S | 0 |
| Automatic dimming rearview mirror | 0 | 0 | 0 | 0 |
| Dual illuminated visor mirrors | 0 | S | S | S |
| Leather-wrapped steering wheel | 0 | 0 | S | NA |
| Tilt steering wheel | 0 | 0 | S | 0 |
| INTERIOR | | | | |
| Heated driver and passenger seat (6) | 0 | 0 | NA | NA |
| Articulated seats | 0 | 0 | S | S |
| Ultrasoft leather trim | 0 | 0 | 0 | 0 |
| PROTECTION | | | | |
| Anti-theft system | 0 | 0 | 0 | 0 |
| Bright rocker panel moldings | 0 | 0 | NA | NA |
| Front floor mats | 0 | 0 | 0 | 0 |
| Front license plate bracket | 0 | 0 | 0 | 0 |
| License plate frames | 0 | 0 | 0 | 0 |
| POWER ASSISTS | | | | |
| Power Lock Group (7) | 0 | 0 | S | 0 |
| Power radio antenna | 0 | 0 | 0 | 0 |
| 6-way power driver's seat | 0 | 0 | S | 0 |
| Dual 6-way power seats | 0 | 0 | 0 | 0 |
| Power seat recliners | 0 | 0 | NA | NA |
| Power side windows | 0 | S | S | S |
| WHEELS/WHEEL COVERS (8) | | | | |
| Locking wire-style wheel covers | 0 | 0 | NA | NA |
| Styled road wheels | 0 | 0 | NA | NA |
| Alloy wheels | 0 | 0 | NA | NA |
| PERFORMANCE | | | | |
| 5.0 liter V-8 engine with EFI/Automatic Overdrive transmission | 0 | 0 | 0 | NA |
| SelectShift automatic transmission with locking torque converter (non-locking with Turbo Coupe) | S | S | NA | 0 |
| Special handling package (included with P215/70HR14 BSW performance tires) | 0 | 0 | 0 | NA |
| Traction-Lok axle | 0 | 0 | 0 | S |
| Heavy-duty suspension (9) | 0 | 0 | NA | NA |
| Medium-Duty Trailer Towing Package | 0 | 0 | NA | NA |
| Heavy-duty battery | 0 | 0 | 0 | S |
| Engine block immersion heater | 0 | 0 | 0 | 0 |
| California Emissions System | 0 | 0 | 0 | 0 |

COLORS & TRIMS

| Interior Trim Colors | | | | | | Exterior Paint Colors |
|----------------------|-------------|------------|--------------|------------|--------------|--|
| Charcoal | Oxford Grey | Canyon Red | Regatta Blue | Sand Beige | Oxford White | |
| • | • | • | • | • | • | Black |
| • | • | • | • | • | • | Bright Canyon Red |
| • | • | • | • | • | • | Midnight Regatta Blue* |
| • | • | • | • | • | • | Dark Sage* |
| • | • | • | • | • | • | Sand Beige* |
| • | • | • | • | • | • | Dark Clove Brown* |
| • | • | • | • | • | • | Oxford White |
| • | • | • | • | • | • | Pastel Charcoal (FILA only) |
| • | • | • | • | • | • | Optional Clearcoat Colors** |
| • | • | • | • | • | • | Silver Clearcoat Metallic |
| • | • | • | • | • | • | Medium Charcoal Clearcoat Metallic |
| • | • | • | • | • | • | Medium Canyon Red Clearcoat Metallic |
| • | • | • | • | • | • | Pastel Regatta Blue Clearcoat Metallic |
| • | • | • | • | • | • | Medium Regatta Blue Clearcoat Metallic |
| • | • | • | • | • | • | Light Sage Clearcoat Metallic* |
| • | • | • | • | • | • | Medium Sand Beige Clearcoat Metallic |
| • | • | • | • | • | • | Optional Two-Tones (Thunderbird, élan) |
| • | • | • | • | • | • | Black/Medium Charcoal Clearcoat Metallic |
| • | • | • | • | • | • | Silver Clearcoat Metallic/Medium Charcoal Clearcoat Metallic |

*Not available with Turbo Coupe lower charcoal accent treatment.
 **This special finish is achieved by applying two coats of highly pigmented low gloss polyester enamel over the primer. Then, final "clear" coats of acrylic enamel are applied for a deep, glossy finish.

Some of these paint and trim colors are shown in this catalog. On the printed page, of course, colors are at best only representative of the originals. Your Ford Dealer can show you actual samples of the paint colors and trim materials presented above.



Have you driven
a Ford...lately?



THUNDERBIRD

