

FALCON for '63



...AND THE NEW SPORTS FUTURA... AND THE NEW FALCON SQUIRE...



... AND THEN THERE'S A GREAT NEW FALCON CONVERTIBLE, TOO!



THAT MEANS THAT FORD WILL BE MAKING 15 FALCONS FOR 1963!

15?

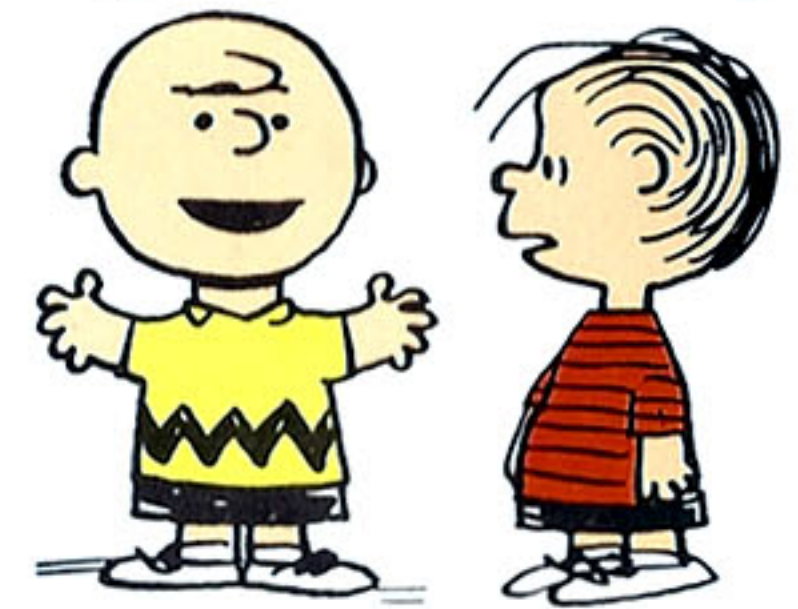

PRETTY SOON THEY'LL HAVE TO GO INTO MASS PRODUCTION!

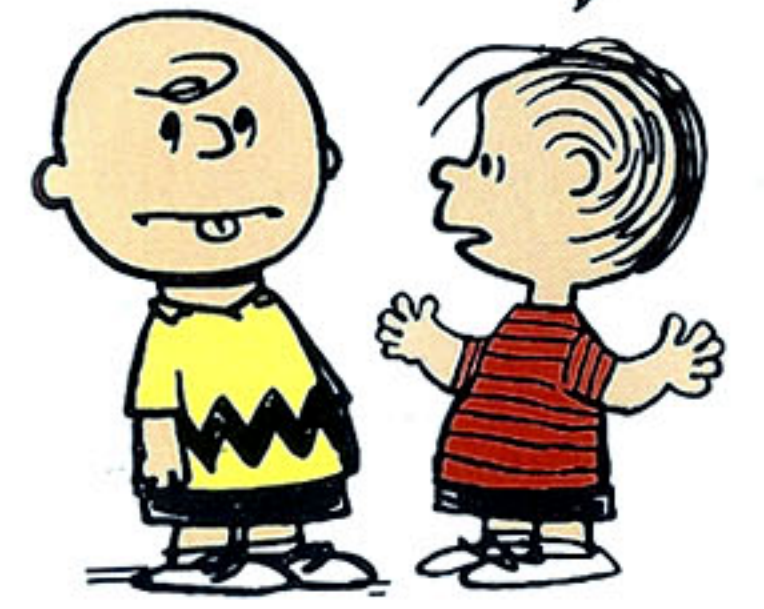

Peanuts characters © 1950-1959 United Feature Syndicate, Inc. Schaefer

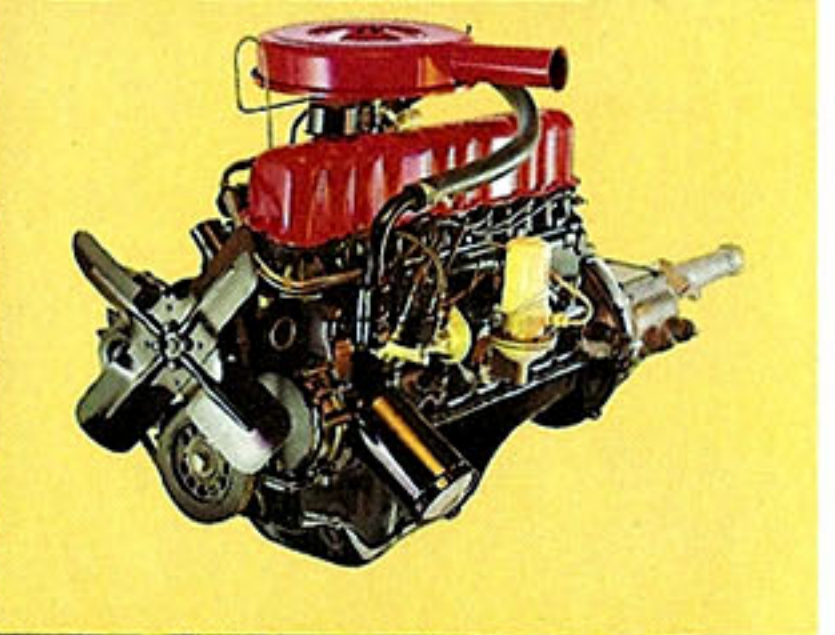
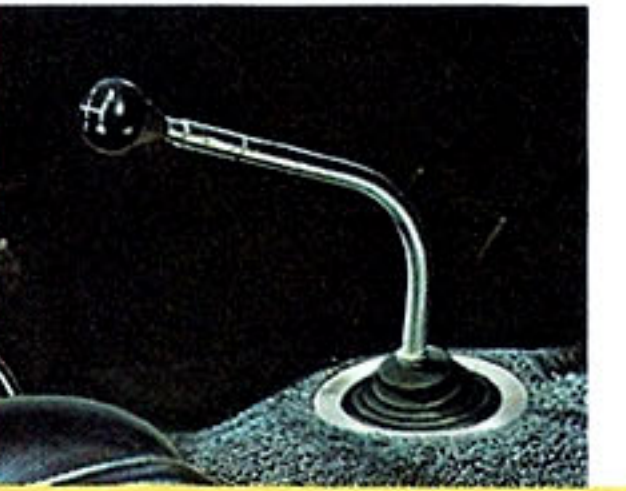

Fifteen different kinds of fun in 15 spunky, spanking-new models . . . that's Falcon for '63. Leading the parade are the liveliest, loveliest funsters of them all—two Falcon convertibles. (One has sporty bucket seats and personal console . . . both have power-operated top as standard equipment.) '63 Falcon sedans have a new look of luxury, topped by smart Thunderbird rooflines. The elegant Futura is now a complete series. And there are eight wagons, each loaded with the wonderful utility that has made Ford wagons famous. For sprightly action choose from

six Falcon power teams starring the 170 Special[§] and floor-mounted 4-speed stick shift*. The savings in Falcon '63 are bigger than ever. America's economy champion now has all the twice-a-year (or every 6,000-mile†) maintenance features pioneered by Ford. You get traditional award-winning gas economy, too. Nicest of all is a price low enough to be the economy news of the year! Sample the great new fun in Falcon now at your Ford Dealer's. *Optional

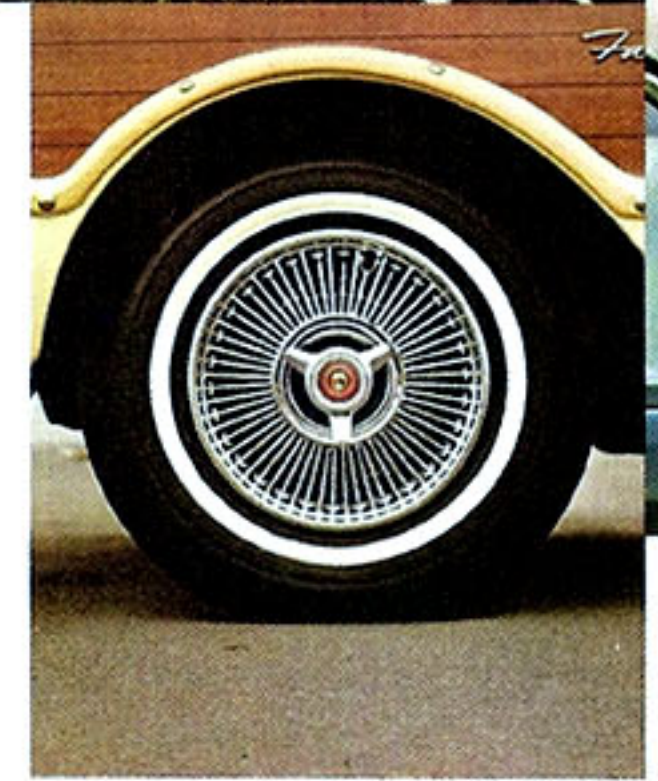

Fun is what's new in Falcon

...the all-time economy champ!

§Standard on convertibles, optional on other models

†Except extra-duty wagons (see footnote page 15)

THE ONLY THING "OLD" about the '63 Falcon is its familiar low price. Compare the Falcon price label model for model with other compacts and see how much Falcon saves you. Then compare features. See how many standard Falcon features are extra cost or simply not available on other compacts. Falcon sure takes the cake when it comes to savings!



FALCON SEDAN INTERIOR. Falcons take first prize in room and comfort. (The wide-opening doors rate it themselves.) Six fit fine in a Falcon—and the big trunk (23.7 cu. ft.) takes all their luggage. In front, you have foam-cushioned seat, 2 sun visors, 2 arm rests. There are even 2 coat hooks. Style touches include color-keyed steering wheel, white vinyl headlining. (Fresh air heater-defroster is included in the price of every '63 Falcon.*)

FALCON SEDAN STANDARD EQUIPMENT

Falcon Six Engine (85 hp) with Self-Adjusting Valves 3-Speed Manual Transmission Self-Adjusting Brakes Full-Flow Oil Filter 36,000-Mile Fuel Filter Fully Aluminized Muffler Galvanized Main Underbody Members Bright-Metal Windshield and Rear Window Moldings Parallel Action, Single-Speed Electric Wipers 2 Horns, 2 Sun Visors, 2 Front Arm Rests, 2 Coat Hooks Foam-Cushioned Front Seat, Front Ash Tray White Vinyl Headlining Gold "Ladder" Pattern Cloth/Vinyl Seat Trim Color-Keyed, 3-Spoke Steering Wheel Front Seat Belt Anchors Turn Signals (with new front safety amber lenses) Center-Fill Fueling

*Heater is installed during production unless otherwise specified. If deleted, an appropriate price reduction is made

DELUXE TRIM PACKAGE

In addition to the above, the following Deluxe Trim items are available at moderate extra cost:
 Bright-Metal Body Side Molding Fender Top Ornaments Choice of Red or Blue Cloth/Vinyl Interior Trim (in addition to standard gold) Rear Arm Rests, Ash Tray Cigarette Lighter Chrome Horn Ring Automatic Dome Light
 See pages 20-22 for Options and Power Teams



Falcon 2-Door Sedan (4-door model also offered)

BASIC SPECIFICATIONS

Over-all Length.....181.1"
 Over-all Width.....70.6"
 Over-all Height.....54.5"
 Wheelbase.....109.5"
 Curb Weight (approx.)—
 2-Door 2409 lb.—4-Door 2446 lb.
 Trunk Volume.....23.7 cu. ft.

See back cover for complete specifications

FALCON SEDANS Like no other compact, Falcon can show you the great fun there is in saving money. There's a lot more fun in a '63 Falcon simply because there's a lot less need for service. Ford's Twice-a-Year Maintenance lets Falcon go 6,000 miles between service stops. In the gas-savings department, Falcon holds the all-time Mobil Economy Run record for 6's and 8's, set in 1961! And, to put the frosting on the cake, Falcon retains its famous low, low price tag—among the lowest for any car in America—with extra savings on licensing and (in most states) insurance! There's no fun like saving money, and no money-saver like Falcon!

FUTURA SEDANS Compact luxury gets a big lift with this brand-new '63 series of Falcons. Starting with style, 2- and 4-door Futuras have the bold, modern beauty of their fine-car "cousin," Thunderbird. (That roofline tells you.) Futura interiors (your choice of five) offer the same smart, good taste from white vinyl headlining to color-keyed carpet to distinctive Futura instrument panel trim . . . plus all the appointments and conveniences of the "high ticket" compacts. To these add Falcon service-saving features . . . Falcon gas-saving economy . . . Falcon's low, low price. Any wonder that Falcon owners already number nearly 1,500,000?

Futura 4-Door Sedan (2-door model also offered)



BASIC SPECIFICATIONS
 Over-all Length.....181.1"
 Over-all Width.....70.6"
 Over-all Height.....54.5"
 Wheelbase.....109.5"
 Curb Weight (approx.)—
 2-Door 2417 lb.—4-Door 2463 lb.
 Trunk Volume.....23.7 cu. ft.

See back cover for complete specifications

FUTURA SEDAN INTERIOR. Open either front door and the "courtesy-lighted" interior beckons you in to solid comfort. Foam-cushioned seats . . . safety-padded arm rests . . . color-keyed carpet front and rear. This trim scheme is handsome deep-pleated blue cloth and vinyl, one of five Futura Sedan choices (plus five all-vinyl optional trims).

FUTURA SEDAN STANDARD EQUIPMENT

Includes the standard equipment and trim items listed on page 4 with these variations:
 Bright-Metal Side Window Frames Side Spear Body Moldings with Complementary Color Inserts Fender Top Ornaments "Futura" in Block Letters and Molding on Rear Body Panel Choice of Five "Bar-Line" Pattern Pleated-Cloth/Vinyl Interior Trims Chrome-Backed Rearview Mirror Color-Keyed Carpet, Front and Rear Cigarette Lighter Rear Arm Rests and Ash Tray Chrome Horn Ring Automatic Dome Light Futura Molding across Instrument Panel and Bright Inserts in Control Knobs Futura Full Wheel Covers

POPULAR OPTIONS AND ACCESSORIES

Choice of Five All-Vinyl Trims *Falcon 170 Special Six (101 hp)* *Fordomatic Drive* *Ford-Aire Conditioner* *White Sidewall Tires* *All-Transistor, Push Button Radio* *Self-Regulating Electric Clock*
See pages 20-22 for Options, Accessories, Power Teams



TWICE-A-YEAR MAINTENANCE. Ford fine-car features proved in Galaxie put you miles and dollars ahead in a '63 Falcon. Add up these service savings for yourself: 36,000 miles between major chassis lubes; 6,000 miles between oil changes and minor lubes. In addition, brakes and engine valves are self-adjusting, and you go 36,000 miles or two years between changes of engine coolant-antifreeze. (See pages 12-13 for more.)



Futura Sports Sedan with optional black vinyl roof covering

FUTURA SPORTS SEDAN Take a liberal helping of Thunderbird elegance . . . add a dash of sports car spirit . . . serve with all the savings of Falcon. That could only be the Sports Sedan. And if you want something special in a compact, this could be the Falcon for you. For elegance: luxuriantly foam-cushioned bucket seats, personal console and leathery all-vinyl trim in vibrant red, black, rich gold, two-tone blue or turquoise are standard (naturally!). For spirit: you can have the peppery 170 Special Six engine* and floor-mounted stick shift 4-speed manual transmission*. Try the Sports Sedan—find all the fun Falcon has for you in '63! *Optional

BASIC SPECIFICATIONS

Over-all Length 181.1"
 Over-all Width 70.6"
 Over-all Height 54.5"
 Wheelbase 109.5"
 Curb Weight (approx.) 2455 lb.
 Trunk Volume 23.7 cu. ft.

See back cover for complete specifications

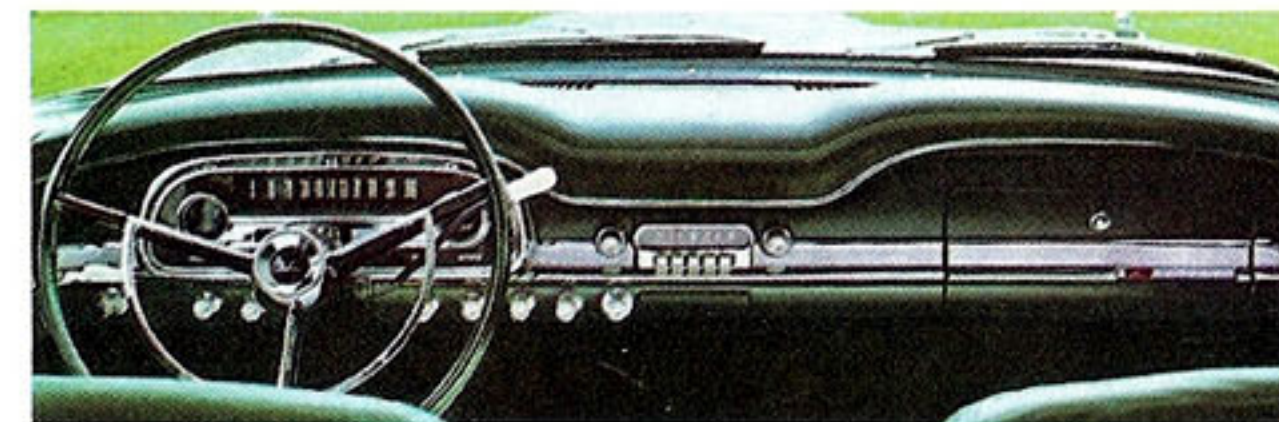

SPORTS SEDAN "ACTION VIEW"—from the driver's seat. Deep-dish, 3-spoke steering wheel is 17 inches big for greater handling ease. Padded sun visors and instrument panel are favored options for style and safety. Instruments and identified controls (illuminated at night) are easily read at a glance, especially the fuel gauge which always seems to register "Full."

SPORTS SEDAN INTERIOR. Rich black vinyl bucket seats (deep-pleated and mylar-accented) adjust individually to suit driver and passenger. Console in between is handy to hold a wide variety of travel items. Color-keyed carpet, bucket-tailored 3-passenger rear seat. Sports Sedan arm rests and trim panels carry out the luxury theme. Additional trim choices include red, blue, gold, and turquoise.

SPORTS SEDAN STANDARD EQUIPMENT

Includes the standard equipment and trim listed on pages 4 and 7 with these variations:
 Foam-Cushioned Bucket Front Seat Cushions and Backs, with Console Bucket-Styled Foam-Padded Rear-Seat Cushion Choice of Five Pleated All-Vinyl Interior Trims Unique White Whipcord Vinyl Headlining Sports Sedan Arm Rests and Ash Trays, Front and Rear

POPULAR OPTIONS AND ACCESSORIES

Grained Vinyl Roof Covering in Black or White with Bright Drip Rail Molding *Falcon 170 Special Six (101 hp)* *4-Speed Manual Transmission* *Padded Instrument Panel and Visors—Seat Belts* *All-Transistor, Push Button Radio* *Self-Regulating Electric Clock* *FordAire Conditioner* *Simulated Wire Wheel Covers*

See pages 20-22 for Options, Accessories, Power Teams



FUTURA CONVERTIBLES Take your pick from this brand-new pair of Falcon fun cars. Whether you go for conventional seats (Futura Convertible) or buckets (Futura Sports Convertible), you'll get the luxury of full-size convertibles for a lot less money. Action is assured with the 170 Special Six standard in both models. In these frisky Falcons, too, you'll have trim handling and slick parkability the big ones can't match. And just compare Falcon's ride with any other compact convertible. Special Ford engineering magic in the body structure makes the ride so much smoother, quieter . . . and the quality built into Falcon as obvious as the fun.

Bucket seat special: Futura Sports Convertible. (Also offered: Futura Convertible with full-width 3-passenger front seat)

BASIC SPECIFICATIONS

Over-all Length	181.1"
Over-all Width	70.6"
Over-all Height	53.8"
Wheelbase	109.5"
Curb Weight (approx.)—	
Convertible	2754 lb.
Sports Convertible	2792 lb.
Trunk Volume	18.7 cu. ft.

See back cover for complete specifications



POWER TOP is standard on every Falcon convertible. Goes up or down smoothly, quietly in seconds—does all the work while you sit, watch and relax. Retracted, top stows trimly under a color-keyed boot emphasizing Falcon's sleek lines. Color choices: black, white, blue—all richly lined in black.



CONVERTIBLE INTERIOR. Deep-cushioned bucket seats, with handy console between, tag this as the Sports Convertible. (Futura Convertible has full-width 3-passenger front seat.) Both Falcon convertibles come luxury-equipped with five pleated all-vinyl choices . . . full carpeting . . . Thunderbird-type "floating" mirror . . . plus many more usually found only on the big, expensive convertibles!

CONVERTIBLE STANDARD EQUIPMENT

Includes Futura standard equipment items from page 7 with these variations:

- Falcon 170 Special Six (101 hp) Choice of Five Pleated All-Vinyl Interior Trims Foam-Padded Front and Rear Seat Cushions
- Electric-Hydraulic Power-Operated Top
- Vinyl 3-Ply Top Material in White, Blue or Black
- Underbody Torque Boxes
- Safety-Yoke Door Locks
- Futura Front Arm Rests
- Front and Rear Ash Trays
- Chrome-Backed "Floating" Windshield Mirror

SPORTS CONVERTIBLE STANDARD EQUIPMENT

In addition to the above includes:

- Foam-Cushioned Front Bucket Seat Cushions and Backs with Personal Console
- Bucket-Styled, Foam-Padded Rear Seat Cushion

POPULAR OPTIONS AND ACCESSORIES

- 4-Speed Manual Transmission 2-Speed Electric Wipers—Windshield Washer
- Simulated Wire Wheel Covers
- White Sidewall Tires
- Bright-Metal Rocker Panel Moldings

See Pages 20-22 for Options, Accessories, Power Teams





EVERY LIVELY new Falcon† for 1963 is equipped with amazing service-saving features that reduce service stops to just twice a year or every 6,000 miles. Ford-pioneered and Ford-perfected, these features are more proof that America's best-built compacts are built by Ford!

†Except extra-duty wagons (see footnote page 15)

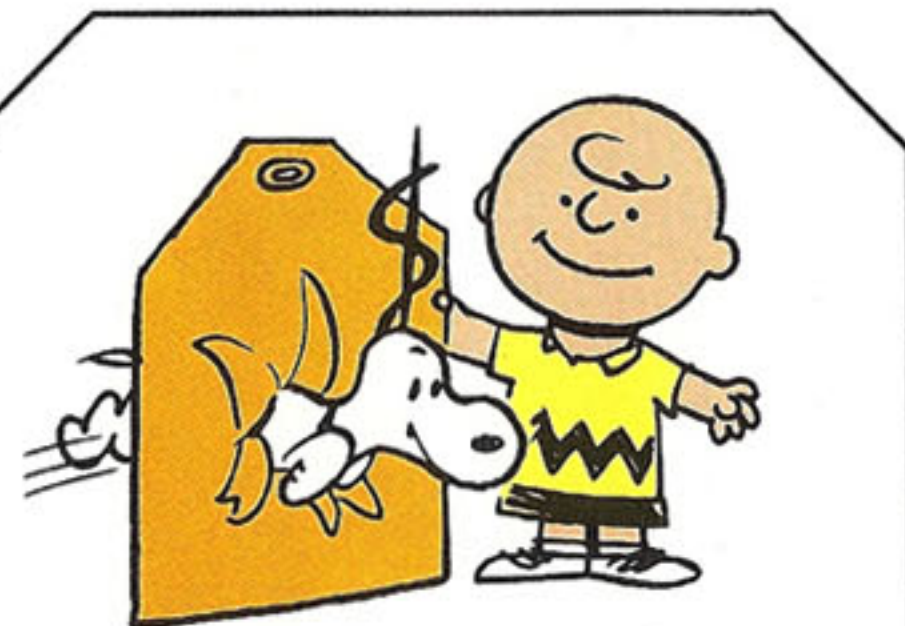

LOW, LOW PRICE . . . From the beginning Falcon has been one of America's lowest-priced cars . . . and '63 is no exception. Falcon beats most other compacts by a good margin on price tag comparisons—beats all others when you compare dollar for dollar on service savings, room, features, luxury, driving fun.



TOP MILEAGE ON REGULAR GAS . . . Falcon gas savings are almost legendary. The standard Falcon Six is the most tightfisted, frugal engine among compacts. This is the engine that set the all-time record for 6's and 8's in the Mobil Economy Run!



TWICE-A-YEAR MAINTENANCE . . . New Falcons let you go 36,000 miles between major chassis lubes . . . 6,000 miles between oil changes and minor lubes. And, you go 36,000 miles between fuel filter changes, 24,000 miles between service of front wheel bearings. Plus 36,000 miles or two years between changes of engine coolant-antifreeze!



MORE BIG SERVICE SAVINGS . . . Leave it to Falcon to give you more! Self-adjusting brakes and engine valves . . . longer-lived fully aluminized muffler . . . galvanized underbody parts to resist rust and corrosion . . . new thicker brake linings designed to last up to 35% longer. Look to Falcon to give you all of these!



LIVELY GOING — SPRIGHTLY HANDLING . . . Falcon comes by both naturally. Try Falcon's peppery 170 Special Six^s and 4-speed floor shift* for sports car fun. Try any Falcon on a tight parking space, in traffic, or the open road. Here's spirit, plus quick, easy handling and big gas savings that never before went so well together or offered such fun! *Optional

§ Standard on convertibles, optional other models



LUXURY FAR BEYOND ITS COST . . . Color-keyed carpeting . . . deep-pleated upholsteries . . . "courtesy-lighted" interiors . . . bucket seats with personal console . . . power tailgate window . . . these are some of the luxuries you get as standard in top-of-the-line Falcons. No other compact near the price equals Falcon's list of big-car luxuries. (Some big cars don't either!)

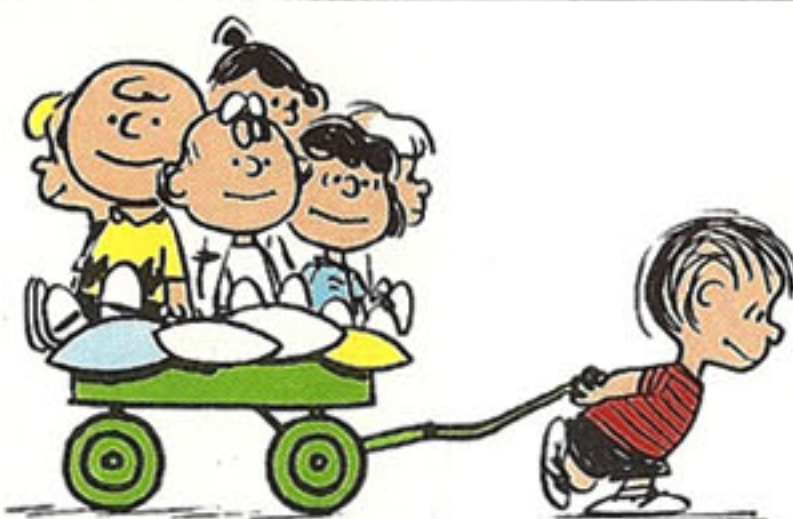

6-PASSENGER ROOM AND COMFORT . . . Falcons have always been built for people—6 people. Falcon standard equipment includes plenty of stretch-out room in foam-cushioned front seats with arm rests, dual sun visors, color-keyed 3-spoke steering wheel and even two coat hooks. Falcon room-for-six also includes a big 23.7-cu. ft. trunk for the luggage of everyone up front.



TOP COMPACT RESALE . . . Nearly 1½ million Falcons already on the road—with more joining them every day! Here's the proof of Falcon's great favor. It's the best assurance of Falcon's continued worth as you drive it . . . the best promise of greater return when it finally comes time to trade!



15 MODELS TO CHOOSE FROM . . . Falcon gives you a bigger helping of everything. Selection includes: 5 sedans, 2 convertibles, 5 wagons and 3 extra-duty wagons. Choose any one (or more) of these 15 and you'll be sure of more driving fun, more savings and more satisfaction with the all-time economy champ!





FALCON WAGON INTERIOR. Compact wagons don't come this handsome unless they're Falcons. Seats are trimmed in rugged, roughhouse-proof vinyl with foam cushioning front and rear. True to the Falcon value formula, you get sun visors, color-keyed, 3-spoke steering wheel, front arm rests—even coat hooks—all standard in the lowest-priced Falcon wagons.

LEAVE IT TO FORD, America's wagon specialists, to give you loadspace like this. No other compact comes close to its usefulness—few equal its size, 76.2 cu. ft! Length: nearly 9 ft. to end of open tailgate (over 7 ft. with tailgate closed). Width: up to 4¾ ft. Cargo mat is standard; handy upright mounting lets you get to spare tire without disturbing cargo.

FALCON WAGON STANDARD EQUIPMENT

Falcon Six Engine (85 hp) with Self-Adjusting Valves 3-Speed Manual Transmission Self-Adjusting Brakes Full-Flow Oil Filter 36,000-Mile Fuel Filter Fully Aluminized Muffler Galvanized Main Underbody Members Bright-Metal Windshield and Drip Rail Moldings Parallel Action, Single-Speed Electric Wipers Front Ash Tray 2 Horns, 2 Sun Visors, 2 Front Arm Rests, 2 Coat Hooks Beige "Steerhead" Vinyl and Pearl Beige Vinyl Interior Trim Foam-Cushioned Seats, Front and Rear White Vinyl Headlining Color-Keyed, 3-Spoke Steering Wheel Front Seat Belt Anchors Turn Signals (with new safety amber lenses in front bumper) Roll-Down Tailgate Window Black Vinyl-Coated Rubber Cargo Mat

POPULAR OPTIONS AND ACCESSORIES

Falcon 170 Special Six (101 hp) Padded Instrument Panel and Sun Visors Seat Belts 2-Speed Electric Wipers—Windshield Washer Fordomatic Drive White Sidewall Tires All-Transistor, Push Button Radio Fresh Air Heater-Defroster*

*Delete option. See footnote page 4

See pages 20-22 for Options, Accessories, Power Teams



Foreground: Falcon 4-Door Wagon (2-door model also offered) Background: Falcon Station Bus †

BASIC SPECIFICATIONS

Over-all Length.....189"
 Over-all Width.....70.6"
 Over-all Height.....54.9"
 Wheelbase.....109.5"
 Curb Weight (approx.)—
 2-Door 2690 lb.—4-Door 2727 lb.
 Cargo Capacity.....76.2 cu. ft.

See back cover for complete specifications

FALCON WAGONS To all the smart style, comfort and convenience of Falcon sedans add extra-big helpings of room and you have Falcon wagons. Easy in-and-out room through big, wide-opening doors. Room for six big adults to ride in foam-cushioned comfort—with more luggage room in back than the trunk space in any full-size car! Fold the second seat down and immediately you have 76.2 cu. ft. of long, wide loadspace ready to take aboard the fixings of a 4-H exhibit, garden supplies, camping gear, or you-name-it. Falcon wagons carry extra-big savings, too . . . Twice-a-Year (or every 6,000-mile) Maintenance†, all of Ford's service-saving features, plus such low price tags that all other compact wagons are green with envy!

†For full details on Falcon Station Bus and Club Wagons, ask your Ford Dealer for a copy of the extra-duty wagon folder



DELUXE WAGON INTERIOR. Look at the others and Falcon looks even better! Here's one of four deluxe trim schemes: red leather-grained vinyls with mylar piping to separate bolsters and deep-pleated inserts. Moldings, steering wheel and floor mats are all beautifully color-keyed; open either front door and the interior is automatically "courtesy-lighted" for your convenience.

DELUXE WAGON STANDARD EQUIPMENT

Includes the standard equipment and trim listed on page 14 with these variations:

Bright-Metal Side and Rear Window Frames
 Deluxe Body Trim and Side Moldings
 Fender Top Ornaments Choice of Four Interior Trims: Three Pleated All-Vinyl, One "Bar-Line" Pleated Cloth/Vinyl Arm Rests and Ash Trays, Front and Rear Cigarette Lighter Chrome Horn Ring Automatic Dome Light Color-Keyed Vinyl-Coated Rubber Floor and Cargo Mats

POPULAR OPTIONS AND ACCESSORIES

Falcon 170 Special Six (101 hp) *Fordomatic Drive*
 FordAire Conditioner *Electric Clock* *Backup Lights* *Whitewall Tires* *Deluxe Wheel Covers*
 Power Tailgate Window

See pages 20-22 for Options, Accessories, Power Teams



COUNTERBALANCED TAILGATE flips open and shut with just one hand. Powerful assist springs (concealed beneath the floor) do the work for you. Strongly hinged and supported tailgate adds nearly two feet to Falcon's loadspace length—extra length for ladders or lumber or other long cargo.

BASIC SPECIFICATIONS

Over-all Length.....189"
 Over-all Width.....70.6"
 Over-all Height.....54.9"
 Wheelbase.....109.5"
 Curb Weight (approx.)—
 2-Door 2708 lb.—4-Door 2746 lb.
 Cargo Capacity.....76.2 cu. ft.

See back cover for complete specifications

FALCON DELUXE WAGONS You're traveling in pretty fancy company with these 2- and 4-door Falcons. Bright-metal side moldings and window frames add sparkling highlights . . . pleated trims in four color choices lend interior richness. They carry a full Falcon wagon payload, of course (76.2 cu. ft.). They include all of Ford's great service savings—36,000 miles between major chassis lubes, 6,000 miles between oil changes and minor lubes, self-adjusting brakes and engine valves, rust- and corrosion-resistant underbody . . . all the rest. Fanciest way to save on any compact wagon, that's the best way to describe a '63 Falcon Deluxe Wagon!

Foreground: *Falcon 2-Door Deluxe Wagon (4-door model also offered)* Background: *Falcon Deluxe Club Wagon (see footnote page 15)*



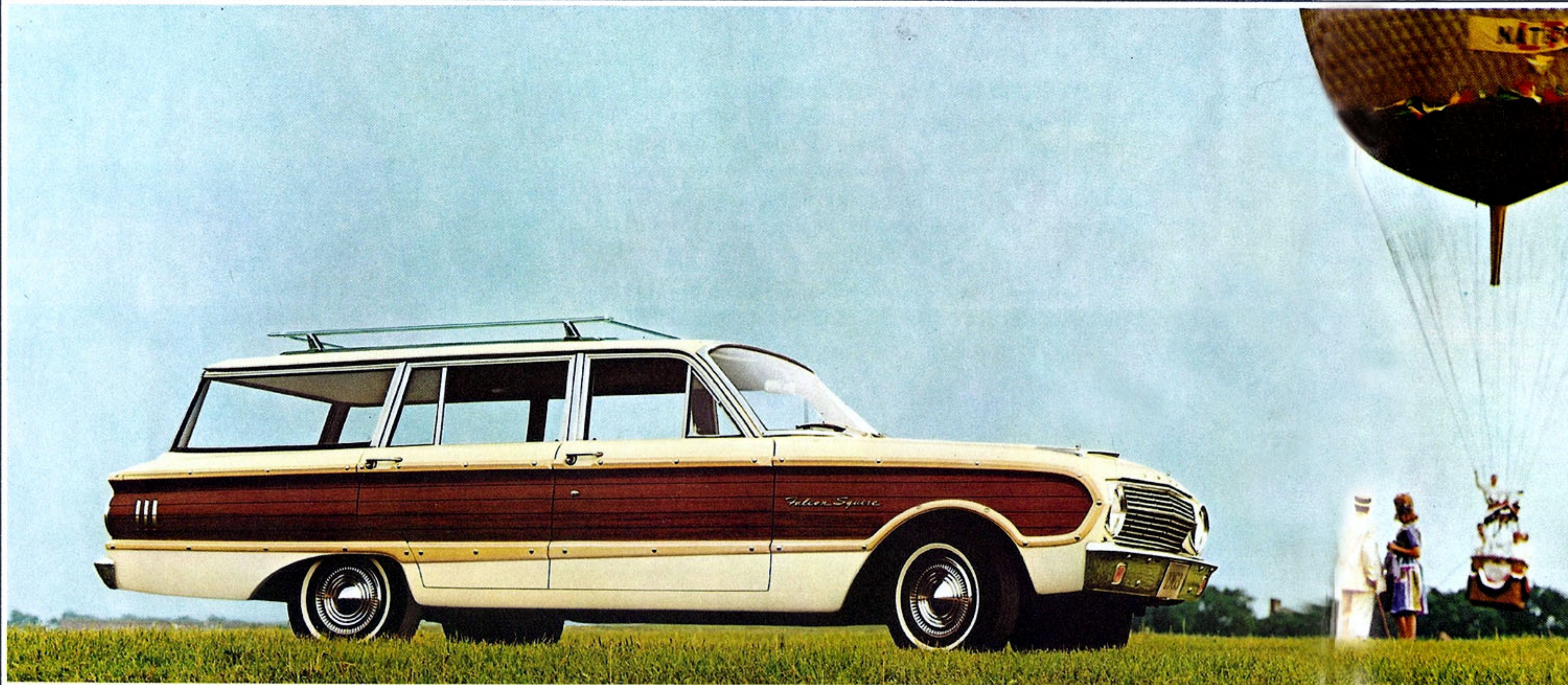

Falcon Squire with optional wagon roof rack

FALCON SQUIRE Here's where other compact wagons fall far behind. In elegance the Squire has the field to itself. Rich simulated wood trim (with the beauty of the real thing and none of the bother) is a styling touch straight from the finest of wagons (also a Ford!). Wall-to-wall carpeting . . . full deluxe trim . . . power tailgate window . . . all are standard. If you want to make your Squire a sports wagon, that can easily be arranged. Try the lively combination of 170 Special Six* and floor-mounted 4-speed stick shift*. (The fun they can wring out of regular gas!) Or, live it up all the way with Squire's most elegant option—bucket front seats and console!

**Optional*

BASIC SPECIFICATIONS

Over-all Length 189"
 Over-all Width 70.6"
 Over-all Height 54.9"
 Wheelbase 109.5"
 Curb Weight (approx.)—
 with Std. Seats 2748 lb.
 with Opt. Buckets 2786 lb.
 Cargo Capacity 76.2 cu. ft.

See back cover for complete specifications

SQUIRE INTERIOR. Two-tone blue vinyl seat trim, with mylar piping and matching carpet, blend with color-coordinated moldings and door panels in one of four Squire choices. For the full sports treatment, select optional Squire bucket seats in choice of three trims and console (as shown on page 9).

FALCON SQUIRE STANDARD EQUIPMENT

Includes equipment listed on pages 14 and 16 with these variations:

Limed Oak Fiberglass Moldings Enclosing Walnut-Colored Steel Panels on Sides and Rear Three Bright Bars (rear side panel) Power Tailgate Window—Operated from Instrument Panel or Tailgate Color-Keyed, Wall-to-Wall Carpeting (passenger area)

POPULAR OPTIONS AND ACCESSORIES

Falcon 170 Special Six (101 hp) 4-Speed Manual Transmission Foam-Cushioned Front Bucket Seats with Console—Choice of Three All-Vinyl Trim Colors—Blue, Red or Black Ford Aire Conditioner Deluxe Wheel Covers Whitewall Tires Backup Lights Electric Clock

See pages 20-22 for Options, Accessories, Power Teams



POWER TAILGATE WINDOW, standard on Squire, lets you regulate ventilation under way from the driver's seat. Simply flip the instrument panel switch and you raise or lower rear window to exact height desired. Key in tailgate lock regulates window from rear when parked. (For safety, window must be completely lowered before tailgate can be opened.)

COLORS & UPHOLSTERIES

Falcon Diamond Lustre Enamel exteriors shown in the color code guide at far right are available with the interior trim color and material combinations indicated on the chart below. Look for the code letter of your exterior color choice under the trim samples shown for your favorite model. For example: Rangoon Red (J) Futura sedans offer gold or red pleated-cloth and vinyl upholstery plus optional pleated all-vinyl trim in gold, red or black. Convertible top colors are (1) black, (2) white or (4) blue.



Sedan Two Tone

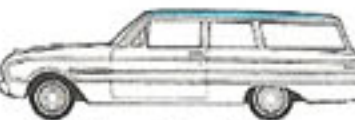











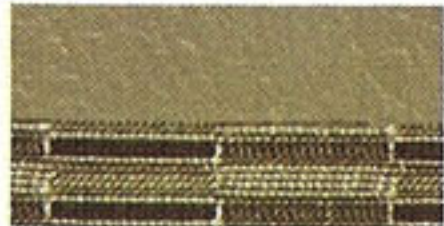
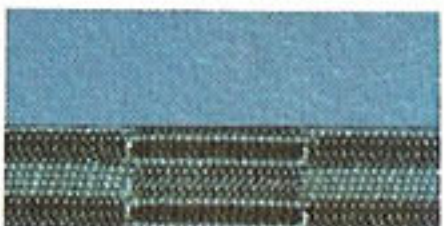



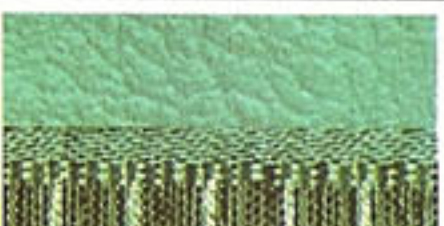
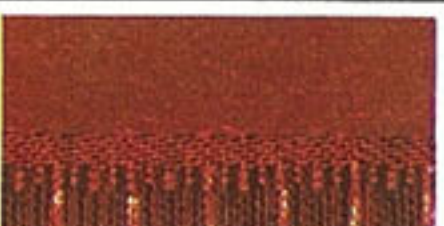

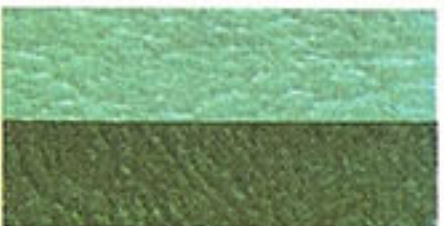

Wagon Two Tone

Two Tone color code letters in the chart below indicate upper and lower color combinations available. The first letter in each box represents the upper body color, the second the lower. Example: "M/Y" is Corinthian White upper and Glacier Blue lower. The lower color determines interior trim color.

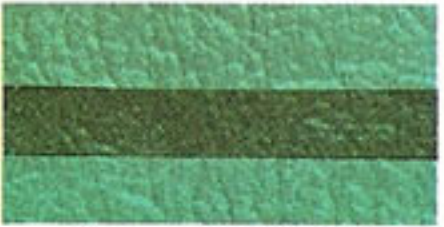
M/A	M/J	M/I	A/I	M/Y	M/E	M/F
Y/E	M/D	M/P	M/T	M/W+	A/W+	M/X

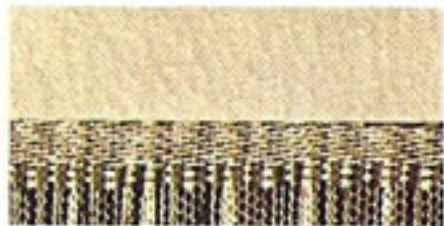
			
A. Raven Black	M. Corinthian White	J. Rangoon Red	I. Champagne
			
Y. Glacier Blue	E. Viking Blue	F. Oxford Blue	D. Ming Green
			
P. Silver Moss	T. Sandshell Beige	W. Rose Beige	X. Heritage Burgundy

+Sports Sedan and Sports Convertible only

FALCON SEDAN	 Gold Vinyl/Cloth A•M•J•I•Y•E•F•D•P•T•X	FALCON SEDAN OPTIONAL TRIM (includes gold trim at left)	 Blue Vinyl/Cloth M•Y•E•F	 Red Vinyl/Cloth A•M•J•I	FALCON WAGON	 Beige "Steerhead" Vinyl A•M•J•Y•E•F•D•P•T•X
FUTURA SEDANS	 Gold Pleated Vinyl/Cloth A•M•J•I•P•X	 Blue Pleated Vinyl/Cloth M•Y•E•F	 Turquoise Pleated Vinyl/Cloth A•M•D	 Red Pleated Vinyl/Cloth A•M•J•I	 Beige Pleated Vinyl/Cloth M•P•T•X	
FUTURA CONVERTIBLE Also Optional for Futura Sedans	 Gold Pleated Vinyl A•M•J•I •Y•E•F•D•P•T•X 1-2	 Blue Pleated Vinyl M•Y•E•F 1-2-4	 Turquoise Pleated Vinyl A•M•D 1-2	 Red Pleated Vinyl A•M•J•I 1-2	 Black Pleated Vinyl A•M•J•I •Y•E•F•D•P•T•W †•X 1-2	§Sedan only †Conv. only
BUCKET SEAT MODELS Sports Sedan, Sports Convertible Falcon Squire (Optional)*	 Gold Pleated Vinyl A•M•J•I•P•X 1-2	 Blue* Pleated Vinyl M•Y•E•F 1-2-4	 Turquoise Pleated Vinyl A•M•D 1-2	 Red* Pleated Vinyl A•M•J•I 1-2	 Black* Pleated Vinyl A•M•J•I •Y•E•F•D•P•T•W †•X 1-2	#Squire only †Sports Sedan and Sports Convertible only
FALCON DELUXE WAGON AND SQUIRE	 Beige Pleated Vinyl/Cloth A•M•J•Y•E•F•D•P•T•X	 Blue Pleated Vinyl M•Y•E•F	 Red Pleated Vinyl A•M•J•I	 Black Pleated Vinyl A•M•J•I•Y•E•F•D•P•T•X		

OPTIONS & ACCESSORIES



ALL-TRANSISTOR RADIO. Completely new, all-transistor design features powerful reception, high sensitivity, rich tone. Transistors provide instant warm-up, low battery load. Five station push buttons. Volume and tuning controls blend smartly into the new Falcon instrument panel.

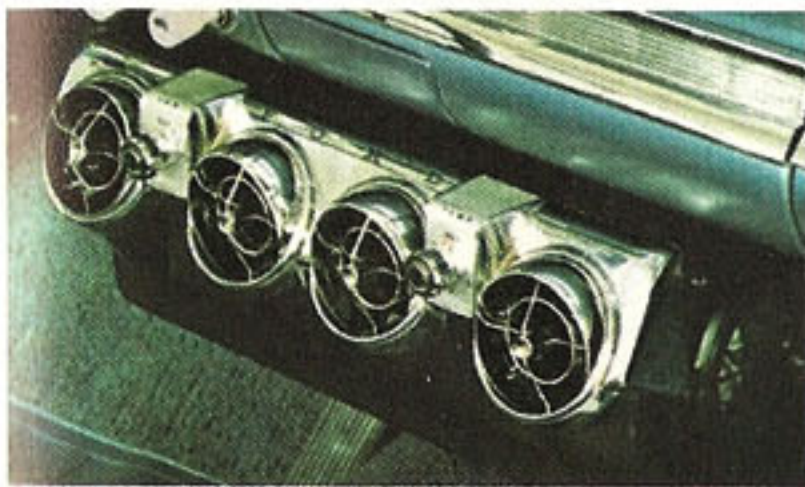

FORDAIRE CONDITIONER. Delightfully cool comfort in a compact, efficient unit with ample capacity for summer's hottest days. Six adjustable outlets to distribute cooled air evenly. Powerful 3-speed blower to assure rapid cool-down. Two controls to regulate blower speed and temperature.

POWER STEERING†. New for Falcon and available on all models. Linkage-type unit reduces steering effort up to 70% with its hydraulic assistance. Retains driver "feel" of the road, adds to driving safety on any road. Especially helpful in parking and low speed maneuvering with load, as with wagons.

†Available approx. Dec. 1962



WHEEL COVERS. Available in two handsome designs: simulated wire wheel design with "knockoff"-styled spinners to lend sparkle and sports car flair; also deluxe stainless steel disc wheel covers with "slotted vent" styling.



BACKUP LIGHTS. Extra safety for nighttime driving plus serving as a backing signal in the daytime. Light automatically when transmission shift lever is moved to reverse. Lights are centered in Falcon's big taillights.

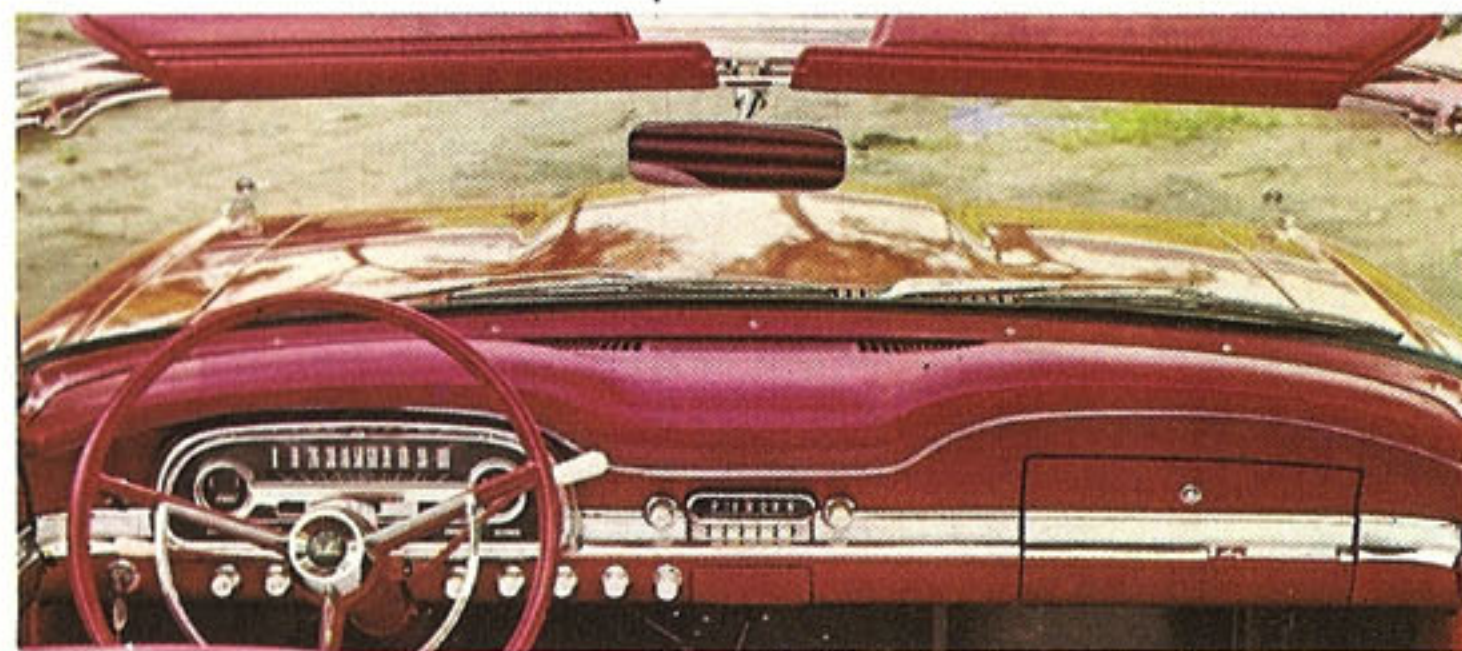

LIFEGUARD DESIGN. Options—At slight extra cost, any Falcon model can be equipped with the following popular safety options: Safety-Padded Instrument Panel and Cushioned Sun Visors; Safety Seat Belts (floor-anchored); "Lifeguard Jr." Door Locks on 4-door models to prevent tiny hands from accidentally opening rear doors. **Standard Equipment**—At absolutely no extra cost, every Falcon offers you these safety features, many pioneered by Ford: Safety-Padded Arm Rests; 3-Spoke, Deep-Dish Steering Wheel; Shatter-Resistant Rearview Mirror; Double-Grip Door Locks (Safety-Yoke type on convertibles), tight-gripping to hold doors tightly closed.

ALSO:

- Self-Regulating Electric Clock
- Contour Floor Mats
- Reverberator-Type Rear Radio Speaker
- Spotlight with Mirror
- Outside Rearview Mirror (several styles)

PLUS:

Two Tone Paint • Tinted Glass • White Sidewall Tires • 2-Speed Electric Wipers • Windshield Washer • Cigarette Lighter • Conventional Rear Radio Speaker • All-Vinyl Interior Trim (Futura Sedans) • Door Edge Moldings • Rocker Panel Moldings • Seat Covers • Ventilated Seat Cushions • Cushion Top Cover • Locking Gas Cap • Heavy-Duty 55 Amp-Hr Battery • Deletion of Fresh Air Heater • Wheel Trim Rings • License Plate Frames, and many others. Wagons Only: Luggage Rack and Cover • Load Area Cover.

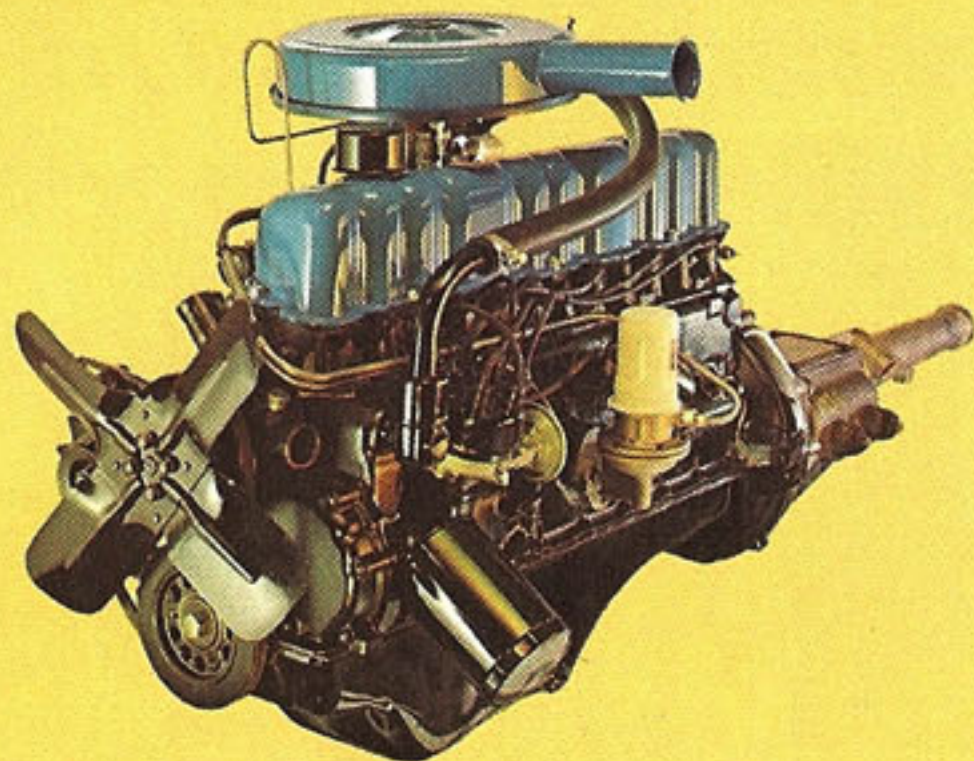

FAMOUS FALCON SIX (standard —except convertibles) . . . 85 hp of sprightly action combined with tightfisted thrift. Works miracles on a gallon of regular and does it for the folks who appreciate it most . . . Falcon owners! New hydraulic valve lifters add quietness and service savings by eliminating need for adjustment.

I LIKE THE FALCON SIX ENGINE FOR ITS TOP ECONOMY WITH PERFORMANCE!



I LIKE THE 170 SPECIAL ENGINE FOR ITS TOP PERFORMANCE WITH ECONOMY!



I LIKE NEW YORK IN JUNE ...HOW ABOUT YOU?

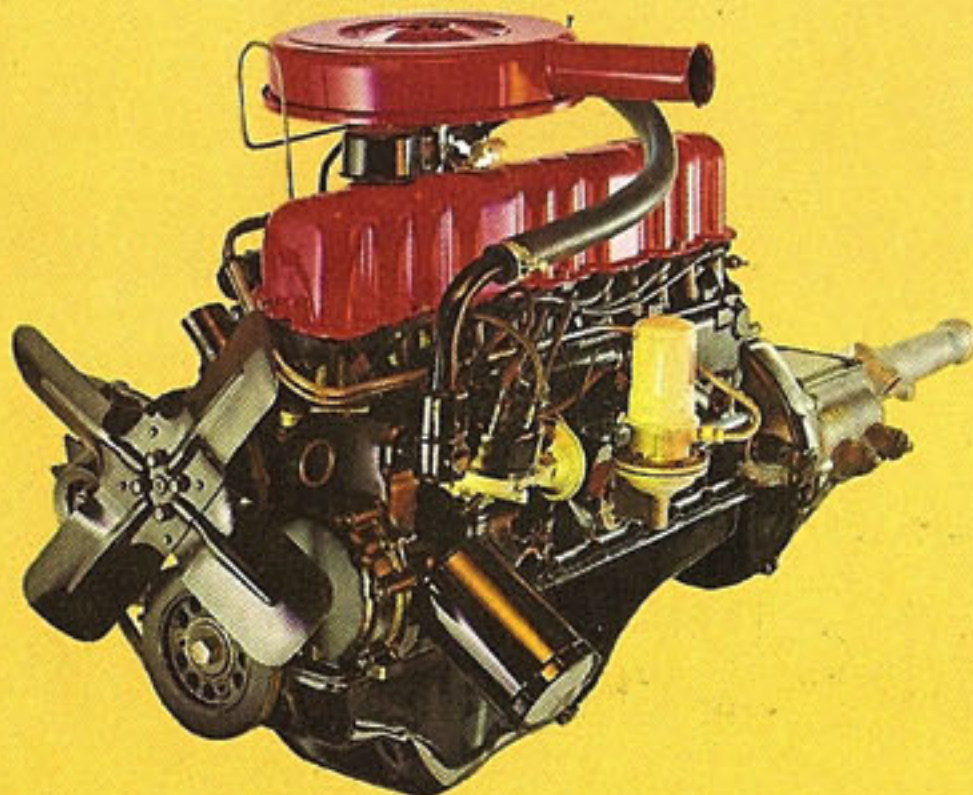

LIVELY FALCON 170 SPECIAL SIX (standard on convertibles, optional on other models) . . . 101 hp of ginger and spunk. Combines greater power for pickup and passing with economy second only to the 85-hp Falcon Six itself. Also features new hydraulic valve lifters. Both Falcon engines are electronically mass-balanced in production for smoothness and long life.

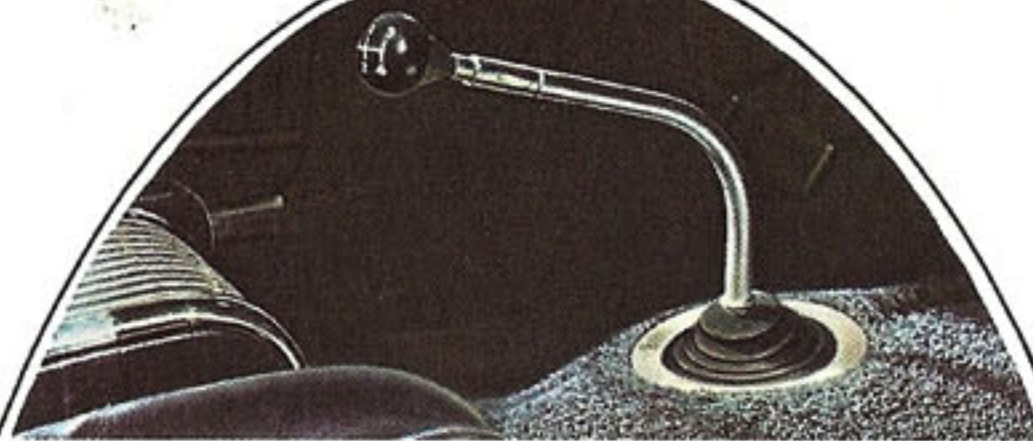

FALCON 4-SPEED. Manual transmission loaded with sports car performance fun. Good economy, too. Floor-mounted stick shift is right at your finger tips. Shift pattern on knob. All forward gears fully synchronized for slick, smooth shifting up or down. Positive reverse gear lockout.



FALCON FORDOMATIC. Simplicity, smoothness and as service-free as any "automatic" can be! Vacuum-controlled throttle valve maintains smooth, precisely coordinated-with-engine shifting for life of transmission. Two-speed drive range. Kick-down passing gear up to 50 mph.

FALCON 3-SPEED. Falcon's standard transmission and a standard for gas-saving economy! Shift lever located conveniently on steering column. Familiar "H" shifting pattern; operation is smooth, easy, simplicity itself.

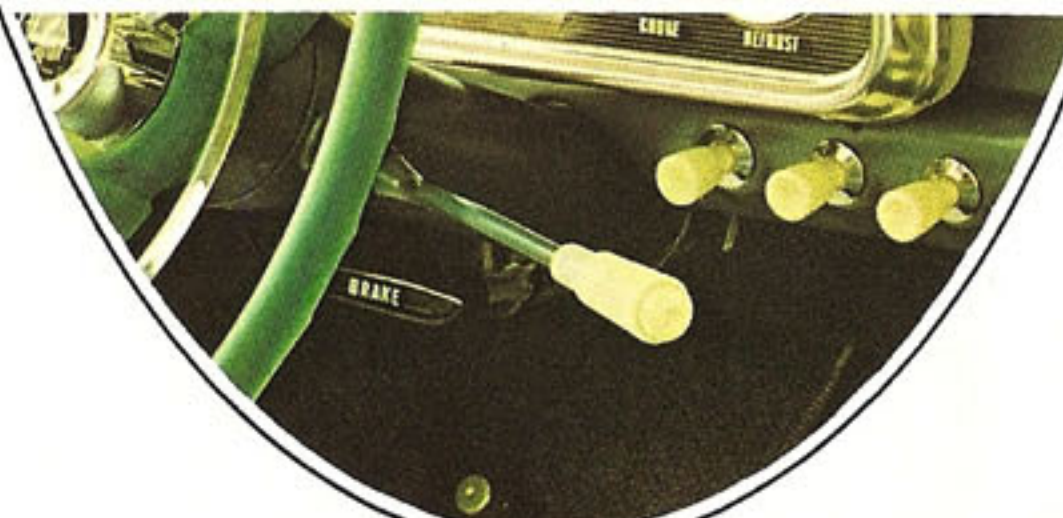



HERE'S HOW FORD BIG-CAR
QUALITY ADDS MORE VALUE
AND WORTH TO EVERY FALCON

50-INCH REAR LEAF SPRINGS
GIVE STABLE, CONTROLLED
BIG-CAR RIDE



IMPROVED FRONT SUSPENSION
EVEN SMOOTHS OUT THE
LITTLEST BUMPS



FALCON'S BIG BRAKES
ARE SELF-ADJUSTING
...MUFFLERS FULLY
ALUMINIZED

NEW EASIER OPENING
HOOD IS COUNTER-
BALANCED...INSULATED

SINGLE-UNIT BODY
FOR GREATEST STRENGTH
WITH LEAST WEIGHT
FULL INSULATION...
INCLUDING THE ROOF...
MAKES FALCONS RIDE
SO-O-O-O QUIET

ALL-VITAL
UNDERBODY
PARTS ARE
GALVANIZED
TO RESIST RUST
AND CORROSION

SPECIFICATIONS†

Your investment in a new Falcon will bring high returns: in sheer driving fun—and in dramatic relief from the bother and expense of frequent car servicing. Routine maintenance for Falcons has now been reduced to just two stops a year, or one every 6,000 miles. The cars from Ford for '63 offer this modern convenience—and for you, this means more time to live the lively life!

In 1963, Ford continues to set new standards of automotive excellence with continuous inspections, tests and evaluations throughout every phase of design, production and assembly. The result is a quality-crafted Falcon—for your lasting pleasure now, and for many, many miles to come.

ENGINES: 85-hp Falcon Six (standard on all models except convertibles)—144 cu. in. displ.; 3.50" bore x 2.50" stroke; 8.7 to 1 comp. ratio; regular fuel; single venturi carburetor; manual choke; hydraulic lifters for automatic valve adjustment; oil capacity, with filter change, 4.5 qt.

101-hp Falcon 170 Special Six (standard on convertibles, optional on other models)—170 cu. in. displ.; 3.50" bore x 2.94" stroke; 8.7 to 1 comp. ratio; regular fuel; single venturi carburetor; manual choke; hydraulic lifters for automatic valve adjustment; oil capacity, incl. filter, 4.5 qt.

ENGINE FEATURES: For inherent economy and longer life Falcon engines have short-stroke, low-friction design; Wedge-Type combustion chambers; Free-Turning overhead intake and exhaust valves; 3-ring aluminum-alloy pistons with full-chrome top ring; integrally cast cylinder head and 6-port intake manifold; water-warmed carburetor spacer; precision-molded crankshaft with four main bearings; rotor-type oil pump; Super-Filter 24,000-mile dry-type air cleaner element; 36,000-mile replaceable element fuel filter; full-pressure lubrication system with Full-Flow disposable-type oil filter; 6,000-mile oil and oil filter change interval; pressurized cooling system with 190° Positive-Action thermostat; 36,000-mile or 2-yr. engine coolant-antifreeze (available—installed in production); 12-volt electrical system; weatherproof ignition; 18-mm. Turbo-Action spark plugs; 54-plate, 40 amp-hr battery; positive engagement starter; fully aluminized muffler and tailpipe; positive crankcase emission control system. All engines electronically mass-balanced for operating smoothness.

CLUTCH AND MANUAL TRANSMISSIONS: Single cushion disc, dry-plate clutch for smooth engagement; aluminum housing; permanently lubricated ball-bearing type throw-out bearing. Face diameter is 8½ in. Total frictional area is 68.1 sq. in. **3-Speed Transmission** (std.) has fine-pitch helical gears treated for high strength and quietness with forged bronze synchronizers in 2nd and direct for smooth operation. Anti-friction bearings throughout. Standard "H" shift pattern with lever on steering column. Ratios (to 1): 1st 3.29, 2nd 1.83, direct 1.00, reverse 4.46. **4-Speed Transmission** (opt.) has floor-mounted "short stick" shift lever, with shift pattern on knob. All forward gears synchronized for

fast, smooth shifting. Ratios (to 1): 1st 3.16, 2nd 2.21, 3rd 1.41 direct 1.00, reverse 3.35.

FORDOMATIC DRIVE (optional): Features simplified design, lightweight cast-aluminum construction, vacuum-controlled throttle valve for smoothness, minimum servicing. Torque converter in combination with compound planetary gear set. Gear ratios (to 1): low 1.82, direct 1.00, reverse 1.73; converter (stall) 2.4. In "D" range gives brisk, smooth starts in low. Effective engine braking in "L" position. Air-cooled with 144 Six, air- and liquid-cooled with 170 Special Six. Selector lever and quadrant on steering column, sequence P-R-N-D-L.

REAR AXLE: Semi-floating type with offset hypoid gears. Induction-hardened forged shafts with permanently lubricated wheel bearings. **Axle Ratios** (to 1): **3-Speed Manual**—Sedans: 3.10 with std. Six, 3.20 with Special Six (3.50 opt., either engine)—Convertible: 3.50 (3.20 opt.) with std. 170 Six—Wagons: 3.50 with both engines; 4.00 opt. with std. Six only. **4-Speed Manual**—Sedans: 3.10 with std. Six (3.50 opt.); 3.50 with Special Six (3.20 opt.)—Convertible: 3.50 (3.20 opt.) with std. 170 Six—Wagons: 3.50 with both engines; 4.00 opt. with std. Six only. **Fordomatic Drive**—Convertible: 3.50 (3.20 opt.) with std. 170 Six—Sedans and Wagons: 3.50 with both engines; 4.00 opt. with std. Six on wagons.

FRONT SUSPENSION: Angle-Poised Ball-Joint type with coil springs pivot-mounted on upper arms. 36,000-mile lubrication intervals. Strut-stabilized lower arms. Threaded, permanently lubricated bushings in upper arms and rubber bushings in lower arms for softer ride. Built-in anti-dive control. Internally mounted hydraulic double-acting shock absorbers with rebound cutoff. Link-type, rubber-bushed ride stabilizer. Tapered roller wheel bearings with 24,000-mile lubrication interval.

REAR SUSPENSION: Longitudinal, semi-elliptic leaf springs with rubber-bushed supports and compression-type shackles, giving variable-rate characteristics for a softer, more levelized ride. Asymmetrical design with rear axle located forward from center of springs for anti-squat control on take-off. Full-length liners between leaves—no lubrication required. Diagonally mounted double-acting shock absorbers.

STEERING: Magic-Circle low-friction recirculating-ball type steering gear provides easy handling. Anti-friction bearings throughout. Permanently lubricated steering linkage joints. Overall steering ratio: 27 to 1. Turning diameter: 38.8 feet.

BRAKES: Self-adjusting, double-sealed, self-energizing hydraulic with composite drums. Diameter, front and rear: 9 in. Molded linings for long life and fade resistance. Total lining area 131.0 sq. in. on sedans, 157 sq. in. on convertibles and wagons.

TIRES: Soft-Tread design, black, tubeless with Tyrex Rayon cord, safety-type rims. Sedans—6.00 x 13 on 4" rims; Convertibles and Wagons—6.50 x 13 on 4½" rims. Spare wheel and tire location: Sedans and Convertibles—luggage compartment; Wagons—cargo area behind right-hand wheelhousing.

PRICES: All Optional Equipment and Accessories, illustrated or referred to as options, optional or available in this catalog are at extra cost. For the price of the Falcon with the equipment you desire, see your Ford Dealer.

SEDAN AND WAGON DIMENSIONS†

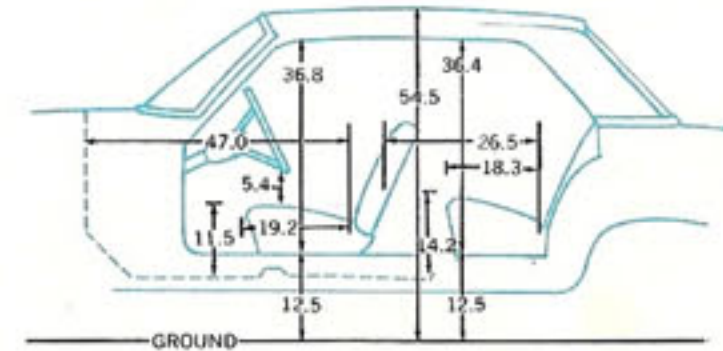

†Wheelbase: 109.5"; Treads: 55" front, 54.5" rear

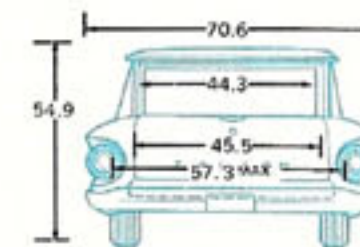
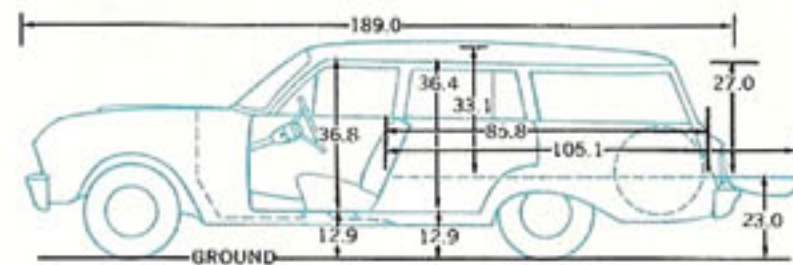
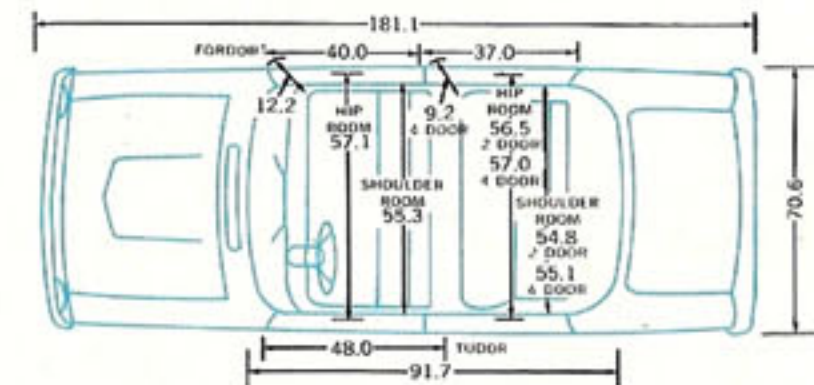

† Except Falcon Station Bus and Club Wagons. For details on these models, including service intervals, ask your Ford Dealer for a copy of the extra-duty wagon folder.

Comparative information in this catalog was obtained from authoritative sources, but is not guaranteed. The specifications contained herein were in effect at the time this catalog was approved for printing. Ford Division of Ford Motor Company reserves the right to discontinue models at any time, or change prices, specifications or designs without notice and without incurring obligation.

PRODUCTS OF  MOTOR COMPANY

YOUR FRIENDLY FORD DEALER