

1969 FORD POLICE CARS & EMERGENCY VEHICLES



*America's No. 1
Police Car*

FORD POLICE CARS...NEW DURABILITY, ECONOMY, STAMINA

1969 Ford Police Cars present all new styling with sleek, long-hood/short-deck proportions. They're longer, lower, wider, yet easier to handle than ever before. And underneath this new exterior styling, Ford presents a police car that's loaded with heavy-duty features, and built for greater around the clock dependability with improved driver/passenger comfort and convenience. The new long, 121-inch wheelbase and wide, 64-inch track, smooth out rough roads and provide better ride and handling characteristics, while maintaining a turning radius that is

less than last year's Ford. New frame to body rubber mounts, and weather sealing materials help make the '69 Fords quieter than ever before. Ford driver comfort and convenience, Ford's famous 100,000 mile front seats provide more comfort and support with thick contour-molded urethane cushions. The new instrument panel places all controls directly in front of the driver in a unique "flight-cockpit" design. Ford's hefty MagicAire heater-defroster has a 25% larger heater core to give faster warmup, more efficient defrosting, plus a more powerful blower that's

located outside the passenger compartment for quiet operation. A new high-low cowl side ventilation provides a flow of fresh air to all parts of the interior. Up front, there's a power plant available to serve every department requirement, from the rugged Police Special Six to the high-performance Interceptor V-8. Check over the following pages for details on additional Police car features plus options to fill your special needs. Then call your fleet salesman at your local Ford dealer and drive the all new Ford... it's the going thing.

New features that are designed to help keep police officers alert highlight the all new 1969 Ford Police Cars.

In a dramatic departure from previous designs, the 1969 Ford INSTRUMENT PANEL presents a totally new concept in driver convenience. All instrumentation and controls are clustered directly before the driver for easy view and reach. The balance of the panel sweeps smoothly away providing exceptional leg room and freedom of movement for the front seat passenger. Underneath this "control center" a new printed electrical circuit provides greater instrumentation reliability. Standard on all models.

Heavy-duty 100,000 mile front seat provides all day comfort with thick 2½" molded urethane foam-padded seat cushions. Firm support is added with special pre-formed main springs and coil springs while optional tough, beige-colored Police vinyl provides a durable easy-clean covering.

Ford's versatile SELECTSHIFT CRUISE-O-MATIC transmission provides the driver the option of completely automatic or manual shifting—to suit the terrain, road condition or traffic conditions. The transmission may be downshifted to second gear for surer starts on ice or for gentle engine braking when required. And, it may be up- or down-shifted for excellent driver control in adverse road or weather conditions. Required option on Interceptor and Cruiser Packages, optional on all other Packages.

Ford's new single-diaphragm POWER FRONT DISC BRAKES provide more positive stops. The cast iron disc is ventilated for better cooling and water dissipation. The braking system is dual hydraulic with dual master cylinders, each independent of the other with its own fluid reservoir and pumping section. Power front disc brakes are standard on Interceptor, optional on all other models.

The latest addition to Ford's family of "police engines"—is the all new advanced design THUNDER JET ENGINE. A 429 c.i.d. 2v V-8 that develops 320 horsepower and 460 pounds-feet of torque. This dependable powerplant is a total performance engine that provides high turbulence wedge combustion chambers and stud-mounted rocker arms. The canted valves open in the direction of the gas flow for free-breathing efficiency. The exceptional low end torque gives the police officer a responsive acceleration capability to overtake quickly before high speeds can be reached.

Features like these that are specially designed for Police duty to provide durability, economy and stamina, continue to make Ford America's leader in police cars.



CUSTOM 500 4-DOOR SEDAN

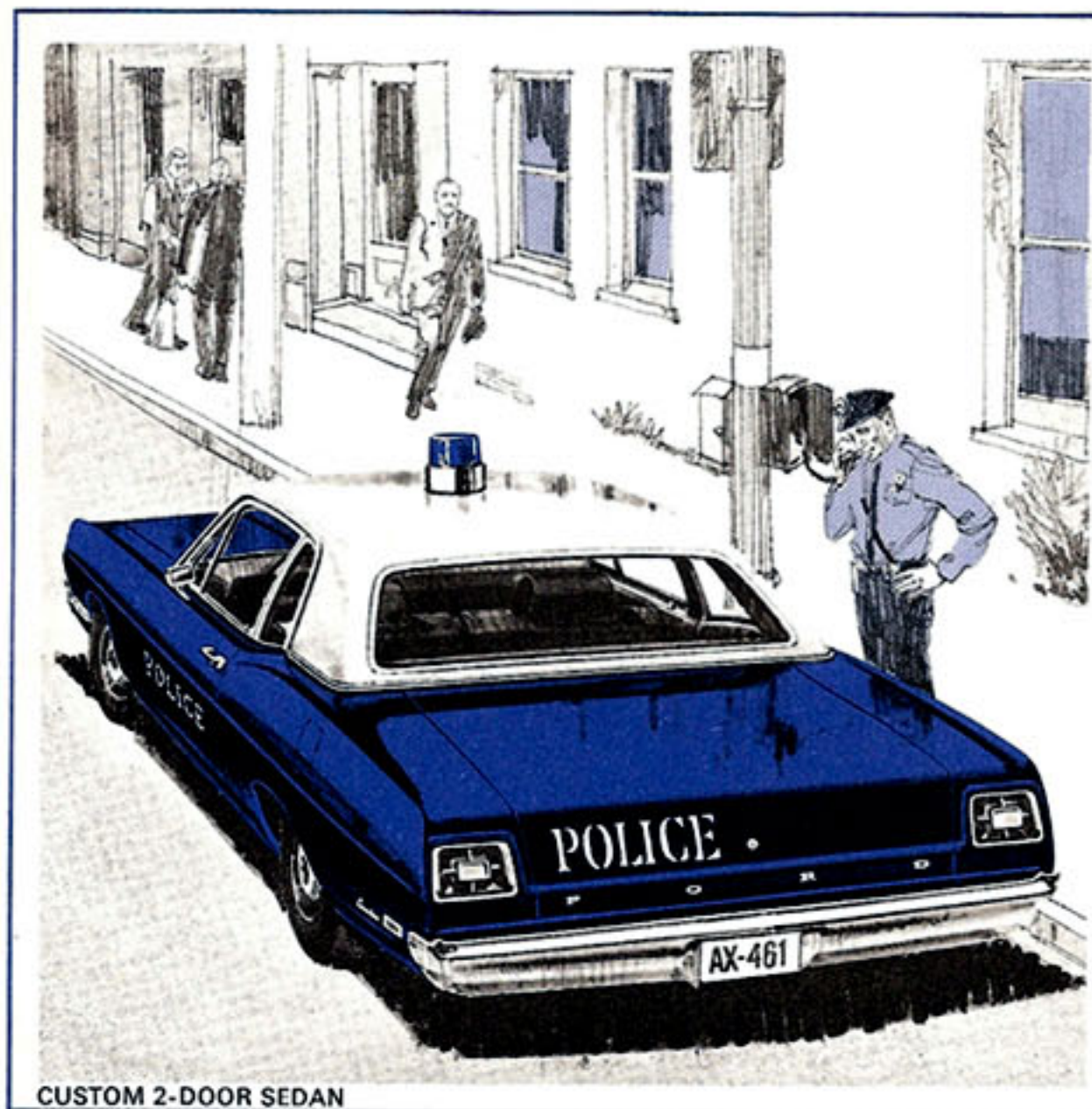

CUSTOM 2-DOOR SEDAN

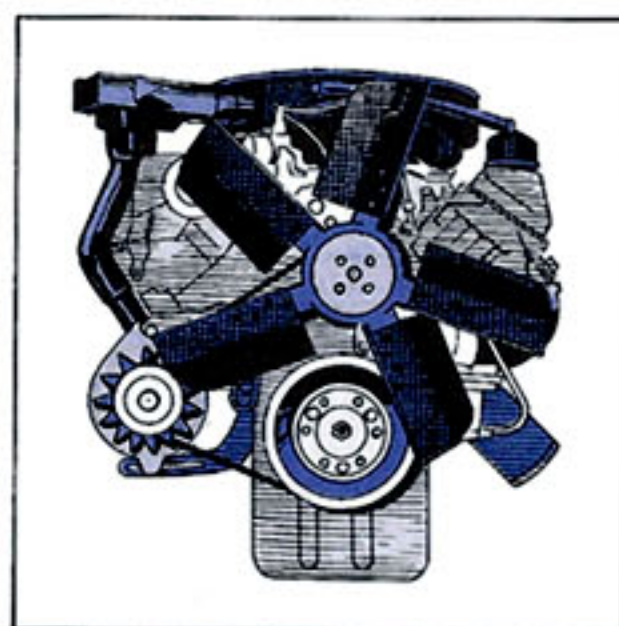
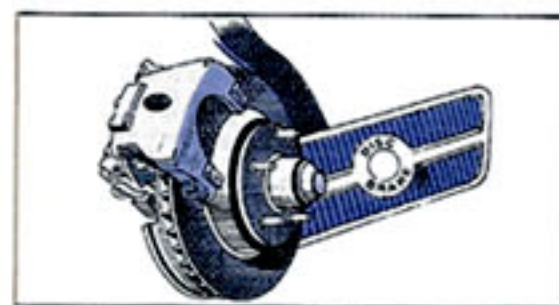
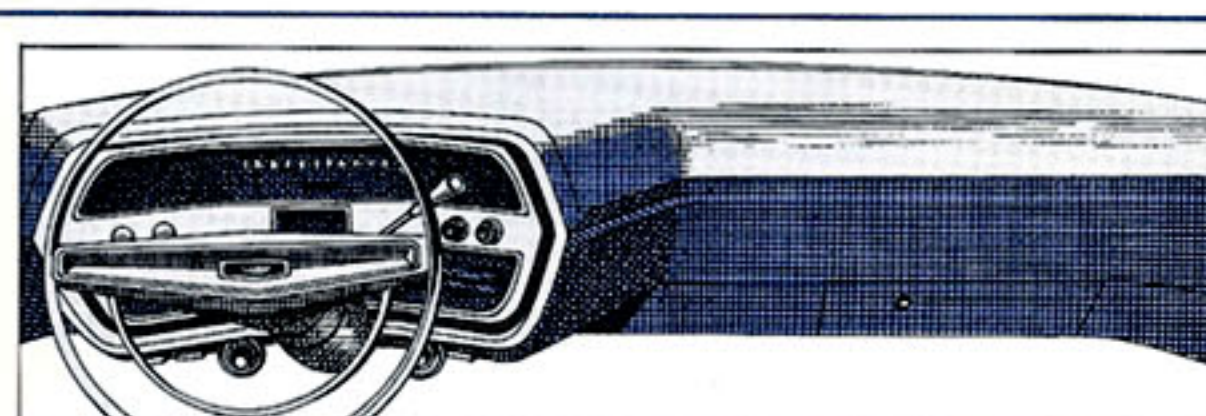

WHATEVER YOUR PATROL... OPEN ROAD OR CITY STREETS THERE'S A FORD "POLICE SPECIAL" PACKAGE TO FIT YOUR NEEDS

"Police Special" packages are specially designed to meet virtually all law enforcement requirements. These extra duty combinations of special components are available on Ford Custom and Custom 500 2-Door and 4-Door Sedans, Galaxie 500 2-Door Hardtops and 4-Door Sedans, Custom Ranch Wagons, Custom 500 Ranch Wagons (6-passenger), and Country Sedan (6-passenger) Station Wagons. The following detailed descriptions of the packages are for your convenience in matching a package to your individual service requirements.

INTERCEPTOR

This is the maximum duty vehicle capable of sustained high speeds. The 428 c.i.d. Police Interceptor engine develops 360 hp at 5400 rpm and 459 lbs. ft. of torque at 3200 rpm. It has 10.5 to 1 compression ratio and requires premium fuel. The Ford designed 4-barrel carburetor offers smooth operation, steady idle characteristics, and reliable warm or cold starting. Chromed valve stems, a high lift cam, heavy-duty valve springs with one piece retainers and high rpm hydraulic valve lifters, plus a free flow dual exhaust system (single in wagons) with aluminized and stainless mufflers give this powerplant its exceptional durability for operation at high rpms.

The Interceptor Package also includes the following Special Police items: Autolite 80-amp. Heavy-Duty Battery □ Autolite 42 amp. Alternator with Dual Belts □ Power Front Disc Brakes with Self-Adjusting Drum-Type Rear Brakes □ Police Maximum Handling Package, with Heavy-Duty Front and Rear Springs, Extra-Control 1 $\frac{3}{8}$ Inch Shock Absorbers, Heavy-Duty Front Stabilizer Bar and Heavy-Duty Front Lower Suspension Arms □ Police Speedometer Calibrated in 2 mph Increments □ Extra Cooling Package with Extra-Fin Density Radiator and Shrouded Flex Fan That Adjusts

Automatically to Demand □ Heavy-Duty Upholstery with Extra Spring base and Fiber and Foam padding □ Heavy-Duty Front and Rear Vinyl Coated Rubber Mats (Galaxie 500 has carpets) □ 6-Inch Safety Rim Wheels and Police Nylon High-Performance Tires □ Heavy-Duty Select-Shift Cruise-O-Matic Transmission (required option) □ Lubricator Fitted Electronically Balanced Drive Shaft □ Heavy-Duty, 9 $\frac{3}{8}$ -Inch Ring Gear and Heavy-Duty Differential □ 3.00 to 1 Axle Ratio.

CRUISER

This vehicle is second only to the Interceptor in total performance. It is especially suitable for use in the suburban areas where its exceptional low end torque gives it the acceleration capability to overtake quickly before high speeds have been reached. The 429 c.i.d. 2-barrel carburetor V-8 engine develops 320 hp at 4400 rpm and 460 lbs. ft. of torque at 2200 rpm with a 10.5 to 1 compression ratio. The single exhaust system features generous area headers with internal deflectors at the ports of the two middle cylinders to assure unrestricted flow. The muffler is aluminized and stainless steel for long life. Other features of the Cruiser Package are the same as the Special Police items listed with the Interceptor Package except that it has a single belt Alternator, a 3.25 to 1 axle ratio with a 9-inch ring gear, heavy-duty self adjusting drum brakes and nylon tires.

GUARDIAN

The Guardian Package is built around the popular 390 c.i.d. 2 barrel carburetor V-8 engine. It fills the requirements for all-around patrol duty, with emphasis on city and suburban cruising. There is ample power available from its 265 hp at 4400 rpm and 390 lbs. ft. of torque at 2600 rpm. Free turn valves and ample bearings account for the long life expectancy of

this popular powerplant. A 9.5 to 1 compression ratio allows the economy of regular gasoline. Also included are 70 ampere-hour battery, single belt drive alternator, single exhaust, 11-inch heavy-duty clutch, three speed all-synchromesh manual transmission with heavy-duty shift linkage, a 3.25 to 1 axle ratio, heavy-duty self adjusting drum brakes and nylon tires. Other features of this package are the same as those Special Police items listed for the Interceptor Package.

SENTINEL

The Ford Police Sentinel provides V-8 smoothness with brisk performance, thrifty operating economy and exceptional durability. The Sentinel is ideally suited to a multitude of duty assignments. The 302-c.i.d. Sentinel engine has 220 hp at 4600 rpm and develops 300 lbs. ft. at 2600 rpm, and a 9.5 to 1 compression ratio allows the economy of regular fuel. This special purpose engine features extra duty bearings, exhaust valve rotators, chrome-plated valve stem tips on both intake and exhaust valves and hydraulic lifters. Extra-duty cooling is provided by a shrouded radiator and a special fan. Other features of this package are the same as those listed for the Guardian Package.

DEPUTY

For General duty, the Ford Police Deputy is an outstanding value for city and suburban patrol or utility duty. The special durability features, economy and smoothness of its 7-bearing six cylinder engine make it ideal for general utility. The 240-c.i.d. Police Special Six develops 150 hp at 4000 rpm and 234 lbs. ft. of torque at 2200 rpm with a 9.2 to 1 compression ratio. The Deputy Special engine features a precision-cast, seven bearing crankshaft, extra-duty bearings, chrome-tipped valve stems, rotators on the exhaust valves, hydraulic lifters with chrome plated plungers, gear driven cam shaft, single barrel carburetor with automatic choke, regular fuel, high-capacity long life fuel filter, disposable type (cartridge replacement) full flow oil filter, single exhaust system with a stainless and aluminized steel muffler. Also included in the Deputy is an 11-inch heavy-duty clutch, 3-speed all-synchromesh manual transmission plus the Special Police items included with the Guardian Package.

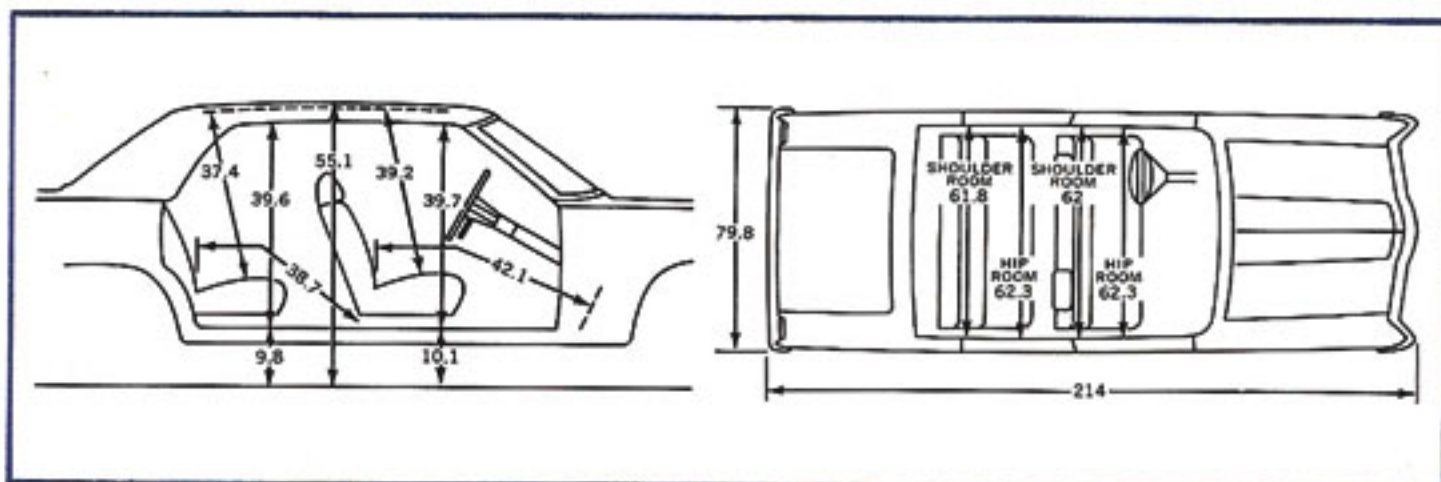

FORD WAGONS...MAXIMUM PERFORMANCE - VERSATILITY



COUNTRY SEDAN 6-PASSENGER

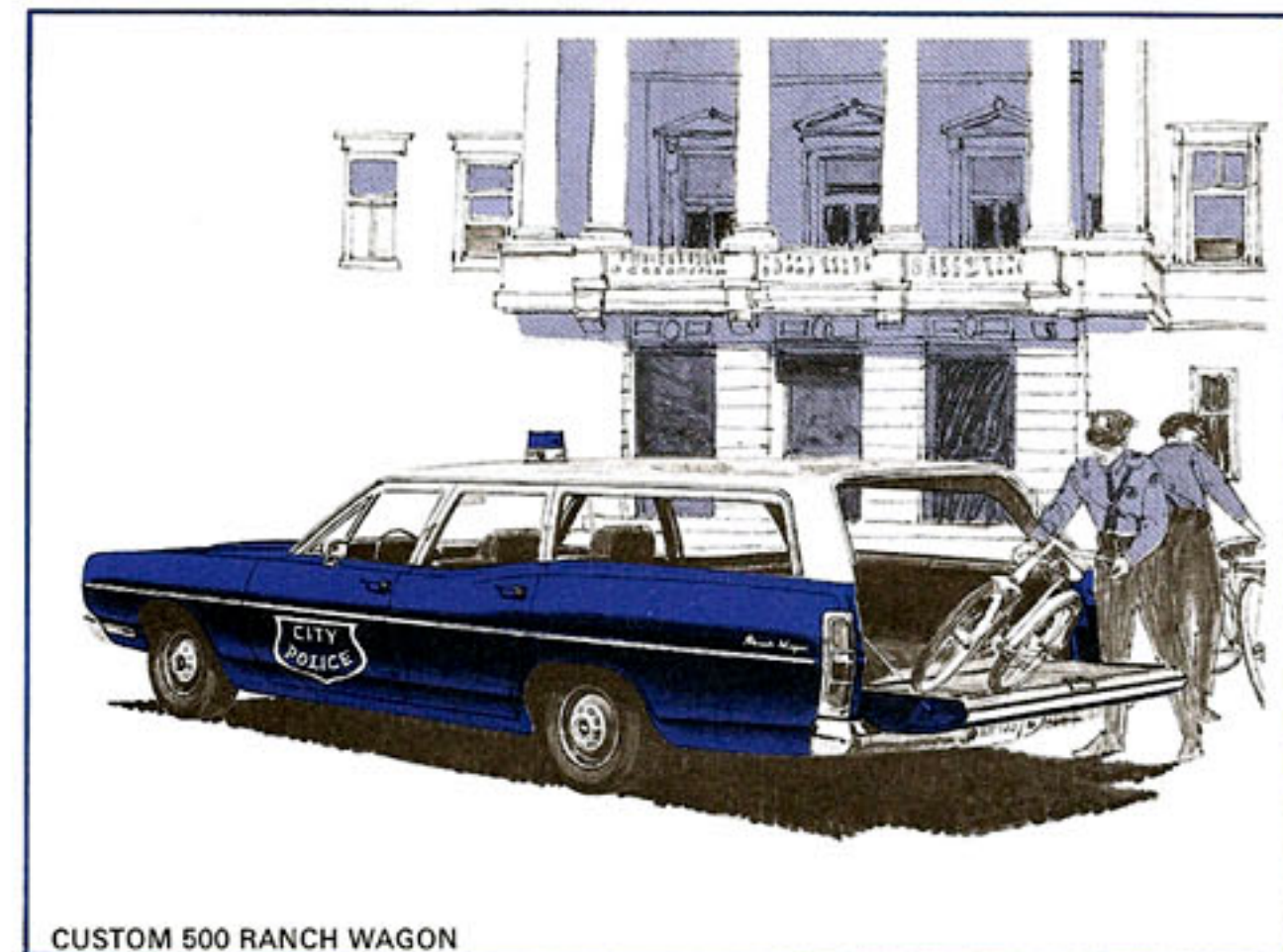

CUSTOM 500 RANCH WAGON

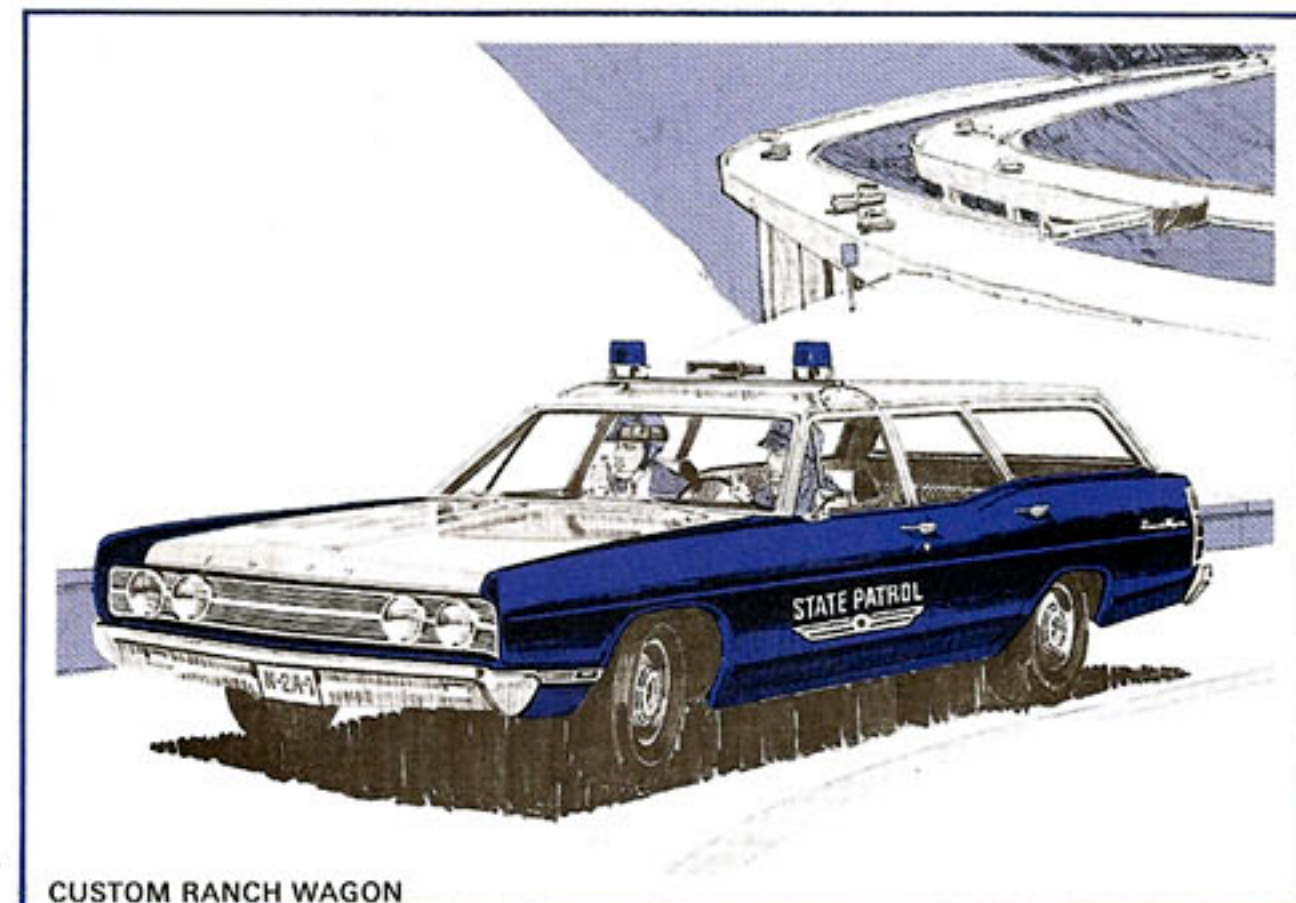

CUSTOM RANCH WAGON

New engineering and product features that provide maximum performance and versatility headline the Ford Station Wagons for 1969. Combine the choice of five "police packages" with an availability of three models, the Custom Ranch Wagon, the Custom 500 Ranch Wagon, and the Country Sedan, add exclusive features such as the new 3-way Magic Doorgate and you'll find a wagon that will fill the needs of your department.

The all-new 3-way Magic Doorgate may be quickly opened as a door with the window up for passengers, or down as a tailgate for cargo. A push button release allows the second seat to be folded flat into the floor to provide a full 96.2 cubic feet of cargo space that's more than 7½ feet long, with the tailgate closed. The extra-long clear floor area allows rapid conversion to emergency stretcher use. A concealed and lockable

area beneath the load floor adds another 9.1 cubic feet of storage space. The "flight-cockpit" design of the instrument panel provides stretch out room for the front seat passenger and places all instrumentation directly in front of the driver for easy viewing. Ford Wagon interiors are furnished in long-wearing vinyl that is easy to maintain and keep clean. The load floors are textured steel covered with a scuff-resistant vinyl base paint.

Ford's long 121-inch wheelbase and 217-inch overall length coupled with a wider track and improved road-hugging suspension are designed to give a remarkable degree of riding comfort and handling ease. All police package station wagons feature rugged heavy-duty components and coupled with a wide selection of options allow you to select a Ford Wagon to your specific requirements.

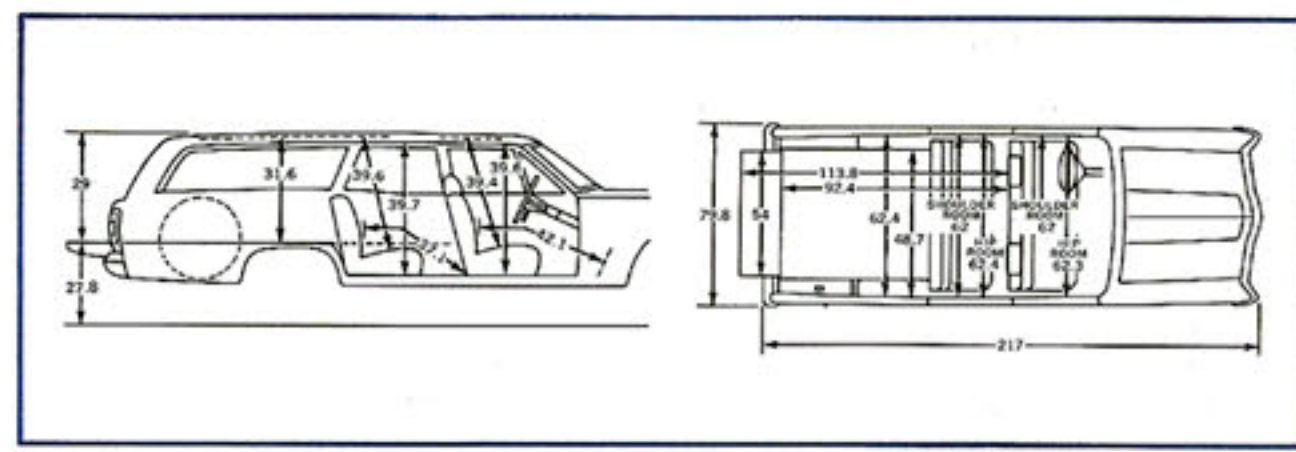



GALAXIE 500 2-DOOR HARDTOP ● GALAXIE 500 4-DOOR SEDAN

SPECIAL PURPOSE VEHICLES

AMBULANCE CONVERSION

Ford's big, roomy station wagons are an ideal choice for police ambulance conversion units. A full 36 square feet of flat floor area behind the front seat provides more than ample room for stretchers and emergency equipment. The exclusive "window up" opening feature of the 3-way Magic Doorgate helps to cut precious time and permits convenient loading and unloading of emergency patients.

Ford Police Ambulance Conversion units are available in either the Country Sedan, Custom 500 Ranch Wagon or Custom Ranch Wagon model with any of the five Police Special packages. Contact your fleet salesman for complete details on ambulance units to fit your particular requirements.

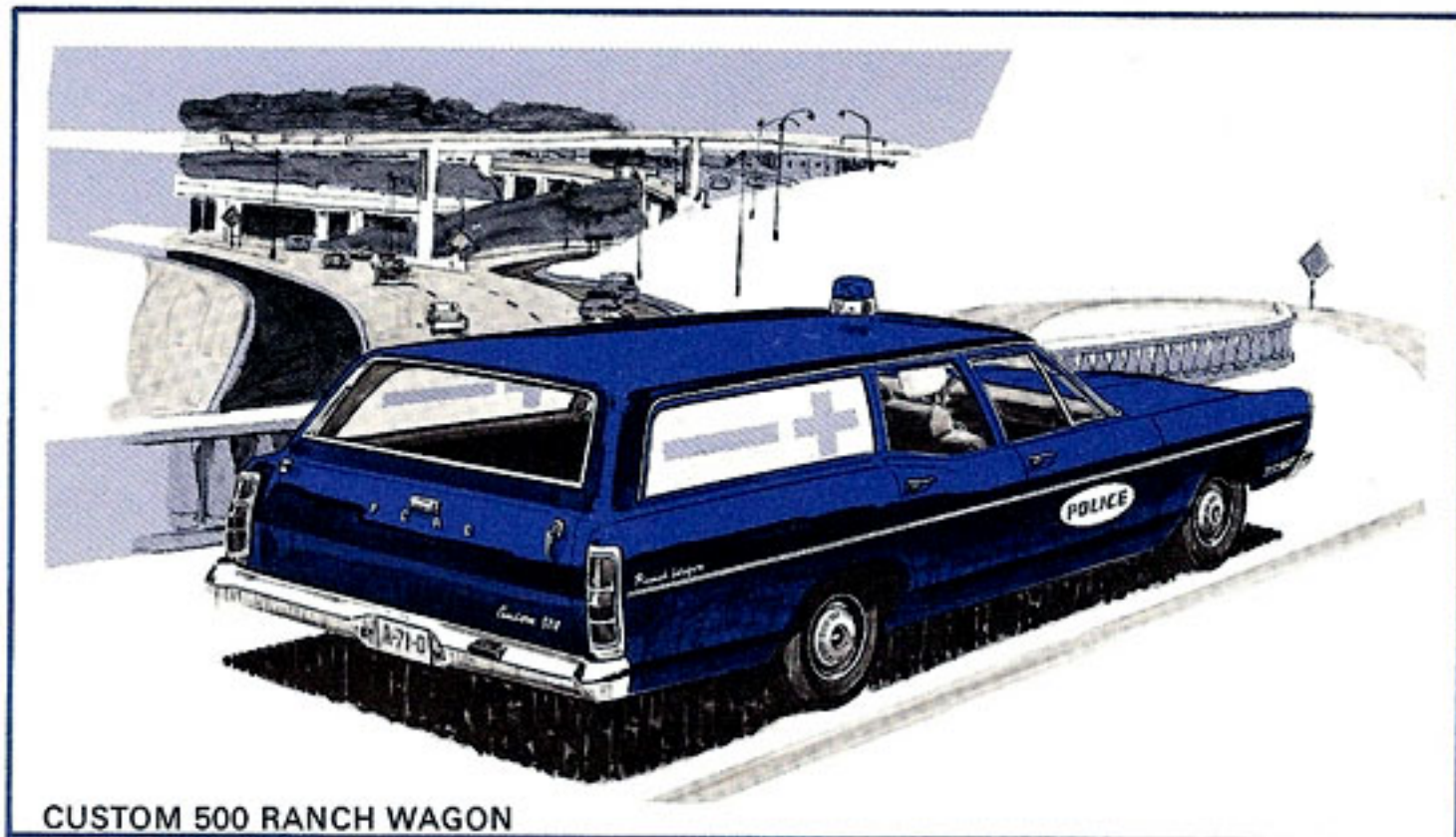

CUSTOM 500 RANCH WAGON

BRONCO

1969 Bronco, the rugged utility vehicle that is capable of going practically anywhere on or off the road, is ideally suited for quick-duty city service or back woods country service. Mono-Beam front suspension and wide 57.4 inch track provides extra road and trail-hugging stability while a 37° turn angle lets the Bronco turn in a small 33.6 foot circle for the maneuverability essential to Police work.

A fully-synchronized 3-speed transmission and a constant-mesh transfer case provide smooth, convenient four-wheel drive operation. Bronco's power plants, either the standard 170-c.i.d. six or the 205 horsepower 302-c.i.d. V-8 give the power needed to carry you across terrain too tough for anything but the best! The Bronco is available in two models: Pick-up and Wagon.

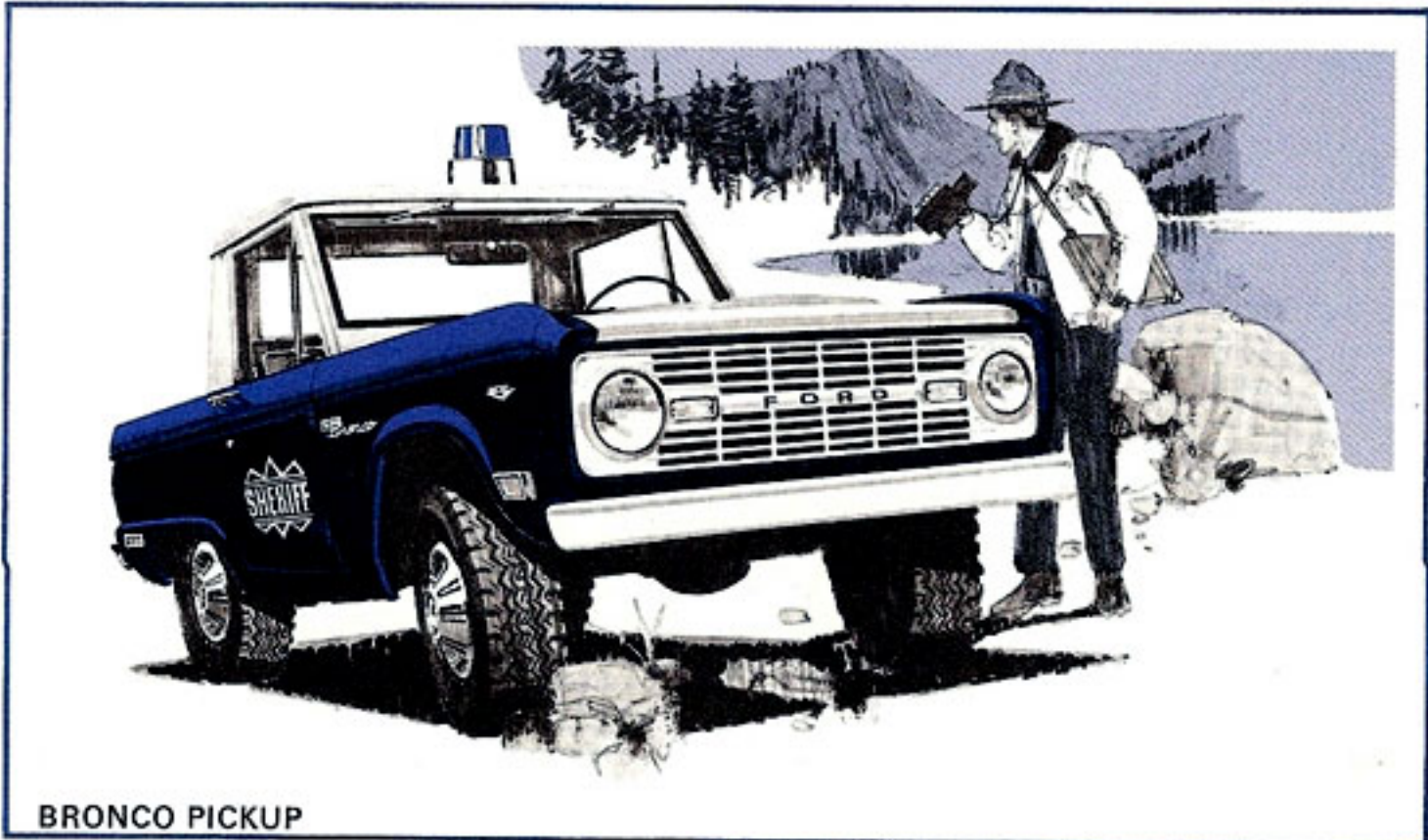

BRONCO PICKUP

1969 FORD MOTOR COMPANY LIFEGUARD DESIGN SAFETY FEATURES

Ever since there have been Fords on the American Road, safety of the people who drive and ride in them has been a primary concern of the Ford Motor Company. Ford engineers have driven millions of test-track miles, worked millions of laboratory man-hours to make each Ford car as strong and reliable as possible. Some of the more recent results of their dedicated work are reflected in the Ford Motor Company Lifeguard Design Safety Features listed here. These Safety Features help reduce the likelihood of injury in case of an accident. However, you can contribute more importantly by preventing an accident.

Every 1969 Ford includes:

- Dual Hydraulic Brake System with Warning Light
- Glare-Reduced Instrument Panel Padding, Windshield Wiper Arms, Steering Wheel Hub, Horn Ring, Rearview Mirror/Mirror Mounting and Windshield Pillars
- Energy Absorbing Steering Column and Steering Wheel
- Energy Absorbing Arm Rests and Safety-Designed Door Handles
- Front and Rear Lap Belts with Front Outboard Retractors
- Turn Indicators with Lane-Change Signal Feature
- Inside Day/Night Yield-Away Rearview Mirror
- Energy Absorbing Instrument Panel with Padding
- Padded Sun Visors
- Two-Speed or Variable-Speed Windshield Wipers
- Windshield Washers
- Double-Thick Laminated Safety Glass

- Windshield
- Double-Yoke Safety Door Latches and Safety Hinges
- 4-Way Emergency Flasher
- Backup Lights
- Side Marker Lights or Reflectors
- Energy Absorbing Front Seat Back Tops with Padding
- Self-Locking Folding Front Seat Backs
- Shoulder Belts for Outboard Front Seat Passengers (except Convertibles)
- Safety-Designed Coat Hooks
- Safety-Designed Window Regulator Knobs
- Safety-Designed Radio Control Push Buttons
- Outside Rearview Mirror, Driver's Side
- Safety Rim Wheels and Load-Rated Tires
- Corrosion-Resistant Brake Lines
- Uniform Transmission Shift Quadrant
- Safety Designed Front End Structure
- Head Restraints for Front Seat Outboard Seating Positions.

POLICE CAR OPTIONS

Ford Car and Station Wagons

REGULAR PRODUCTION OPTIONS

Air Conditioner—SelectAire (not available with 240-c.i.d. engine)
 Alternator—55 Amp. dual belt
 Brakes—Power front disc (standard on Interceptor)
 Electric Clock*
 Intermittent Windshield Wipers
 Mirror*—Remote control
 Power Steering
 Power Door Locks
 Power Tailgate Window—(Station Wagons only)
 Radio*—AM (with front fender antenna)
 Rear Axle—Limited-Slip differential
 Rear Window Defogger*—(Not available on Station Wagons)
 Station Wagon Load Floor Carpeting
 Steering Column—Tilt (requires automatic transmission and power steering)
 Tinted Glass—Complete (all-around) with banded windshield
 Transmission—Cruise-O-Matic (required on Interceptor and Cruiser)
 Visibility Group—includes light package, rear door courtesy switches and remote control outside rearview mirror.

*Also available as DLR

LIMITED PRODUCTION OPTIONS

Alternator—65 ampere (Autolite)—not available on Deputy—65 ampere (Leece-Neveille)—not available on Deputy or Sentinel
 Radio Interference Suppression System
 Roof Light Wiring
 Single Key Locking System
 Tinted and Banded Windshield only (Fleet use only)
 Tires—8.15 x 15 BSW Nylon Police Hi-Performance (standard on Interceptor)
 —8.15 x 15 WSW Nylon Police Hi-Performance
 —8.55 x 15 BSW Nylon (standard on Station Wagons, not available on Interceptor)
 —8.55 x 15 WSW Nylon (not available on Interceptor)
 —8.55 x 15 BSW Nylon, Police Hi-Performance
 —8.55 x 15 WSW Nylon, Police Hi-Performance
 Vinyl Trim—Heavy-Duty, Beige

DEALER-INSTALLED ACCESSORIES

Bumper Guards—Front and Rear (Front only on Station Wagons)
 Bumper Steps (Station Wagons only)
 Fire Extinguishers
 Mud and Stone Deflector (Station Wagons only)
 Parking Brake Warning Light
 Remote Rear Deck Lid Release
 Rubber Cargo Deck Mat (Station Wagons only)

DOMESTIC SPECIAL ORDER

The range of options available as DSO is so large that it is impossible to print an entire or exact list for you; in fact you may even have need for a new DSO that is not even on our list.

Basically, a DSO item includes almost anything you would require on a police vehicle . . . simply ask your fleet salesman for assistance in determining availability of an item.

Econoline Van and Club Wagon

REGULAR PRODUCTION OPTIONS

Alternator—heavy-duty rating
 Axle—heavy-duty 4800 pound rating
 Battery—heavy-duty rating
 Cab and Miscellaneous Equipment—(refer to detailed listing in consumer catalog)
 Clutch—Heavy-duty 11 inch
 Engine—240-c.i.d. six-cylinder
 Engine—302-c.i.d. V-8
 GVW Rating Plate—heavy-duty
 Suspension Components—heavy-duty
 Transmission—3-speed Cruise-O-Matic
 Tires and Wheels—Oversize and heavy-duty rating

Bronco

REGULAR PRODUCTION OPTIONS

Alternator—heavy-duty rating (55 amp.)
 Auxiliary Fuel Tank (11.5 gal.)
 Battery—heavy-duty rating (70 amp.)
 Dana Free-Running Front Hubs
 Engine—302-c.i.d. V-8
 Extra-Cooling Equipment
 Hand-Operated Throttle
 Radio—Manual, AM
 Swing-Away Spare Tire Carrier

EXPLANATION OF TERMS

RPO—Regular Production Option. Equipment advertised nationally and available from production stock.

LPO—Limited Production Option. Equipment generally used only by fleet and commercial accounts.

DLR—Dealer Installed Accessories. Equipment which is readily available and capable of being installed at the dealership.

DSO—Domestic Special Order. Specific procurement, with time necessary to fill order.

ALTERNATORS

Alternators must meet the electrical load requirements for the vehicle at average driving speeds, plus supply sufficient output to charge the battery. To determine the required alternator size, find the electrical item group in the Ampere-Draw Table that best describes your vehicle equipment.

AMPERE-DRAW TABLE

Electrical Equipment Groups	Average Ampere Draw	Recommended Alternator
STANDARD LOAD : Includes ignition, gauges, regulator, all lighting turned on by headlamp switch, heater motor, electric wipers plus All-Transistor, Two-Way Radio	28	42-Amp.
Standard Load plus : Tube-Type Two-Way Radio ; or Transistor Ignition ; or Ford Air Conditioner†	32	55-Amp.
Standard Load plus : Transistor Ignition and Ford Air Conditioner†	34	55-Amp.
Standard Load plus : Tube-Type Two-Way Radio and Transistor Ignition ; or Tube-Type Radio and Ford Air Conditioner†	55	65-Amp.

†Ford SelectAire has 55-amp. alternator as standard equipment

POLICE CAR POWER TEAM SELECTIONS

FEATURE	DEPUTY	SENTINEL	GUARDIAN	CRUISER	INTERCEPTOR
Engine	240 1v 6-cyl.	302 2v V-8	390 2v V-8	429 2v V-8	428 4v V-8
Displacement (cu. in.)	240	302	390	429	428
Horsepower at rpm	150 @ 4000	220 @ 4600	265 @ 4400	320 @ 4400	360 @ 5400
Torque (lbs.-ft.) at rpm	234 @ 2200	300 @ 2600	390 @ 2600	460 @ 2200	459 @ 3200
Compression ratio	9.2:1	9.5:1	9.5:1	10.5:1	10.5:1
Alternator (belt drive)	Single	Single	Single	Single	Dual
Transmission	3-Speed Manual	3-Speed Manual	3-Speed Manual	†Cruise-O-Matic	†Cruise-O-Matic
Clutch Diameter	11-inch	11-inch	11-inch	—	—
Battery (amp. hr.)	70	70	70	80	80
Rear Axle Ratios	3.25	3.25	3.25 (3.00)#	3.25 (2.75)#	3.00 (2.80)#

†Heavy-duty Cruise-O-Matic transmission option required at extra cost.

#Ratios in parentheses are optional.

ECONOLINES & CLUB WAGONS . . .



CUSTOM CLUB WAGON 123

Ford for '69 has introduced a *second generation* of Econolines and Club Wagons. Inside and out, bumper to bumper, and from tires to roof they're full of "better ideas" that put them way ahead of similar competitive vehicles.

Club Wagons are ideal for light personnel carriers and can transport groups of men quickly and conveniently. They are available with seating arrangements for 5, 8, or 12 passengers, and 9 passengers with a table—an ideal "police command post" arrangement. The 5-, 8-, and 9-passenger models are built on either the 105.5 or 123.5 inch wheelbase while the 12-passenger model comes only on the 123.5 inch wheelbase.

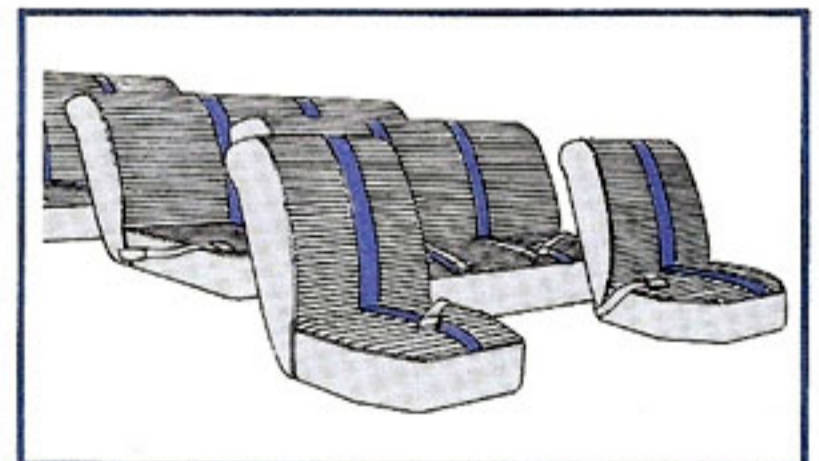

All rear seats can be removed with simple hand tools to convert the Club Wagon to a two-passenger vehicle with maximum load space.

Econolines come in three body styles . . . the Cargo Van, the Display Van, and the Window Van. Cargo Vans have solid side and rear doors and panels and are ideal

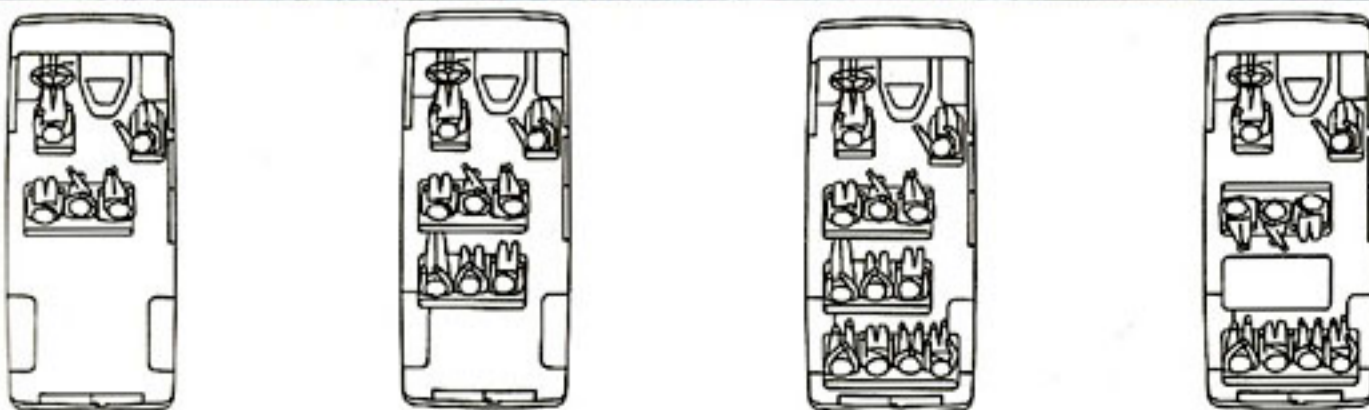

MORE VERSATILE THAN EVER

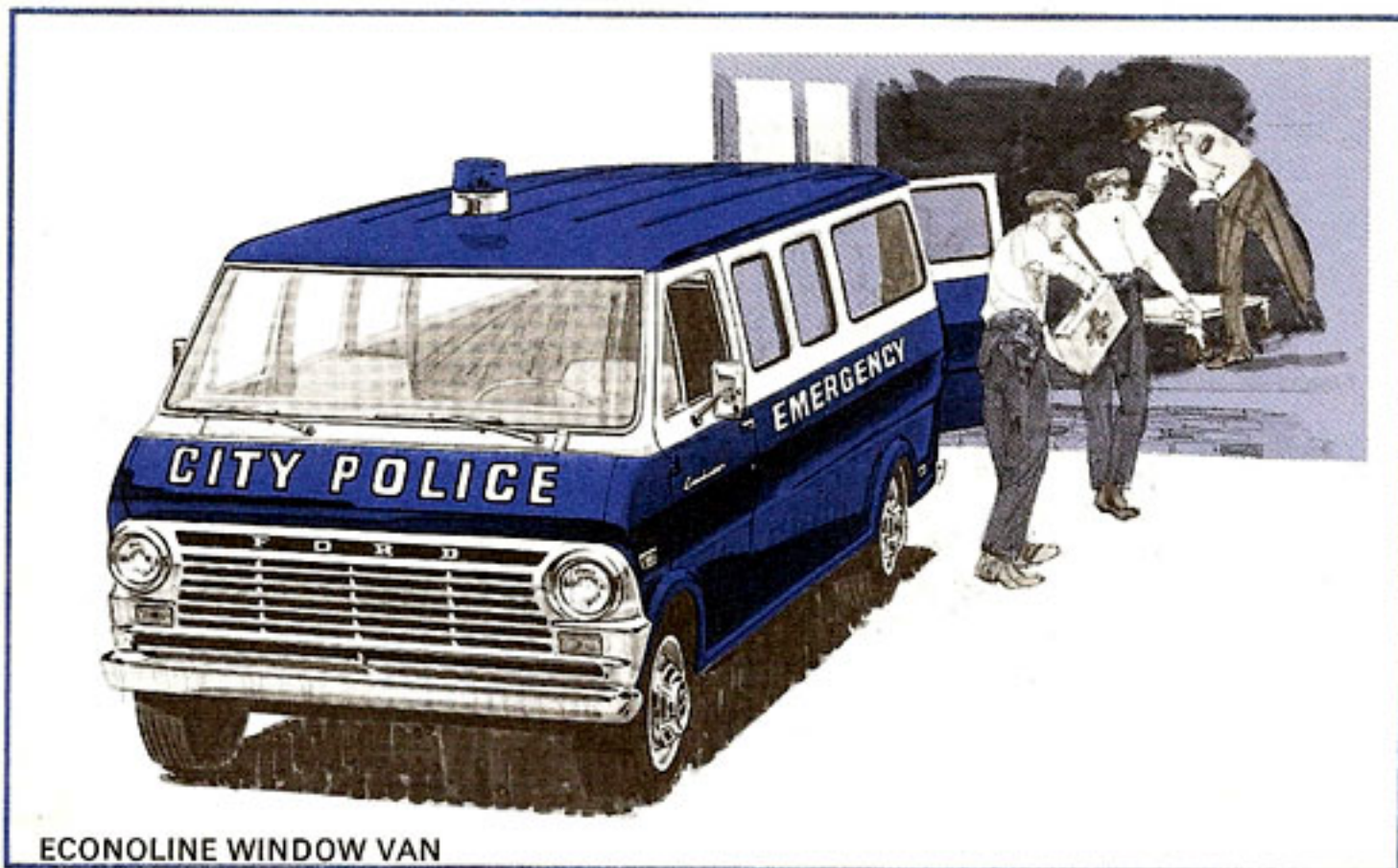

ECONOLINE WINDOW VAN

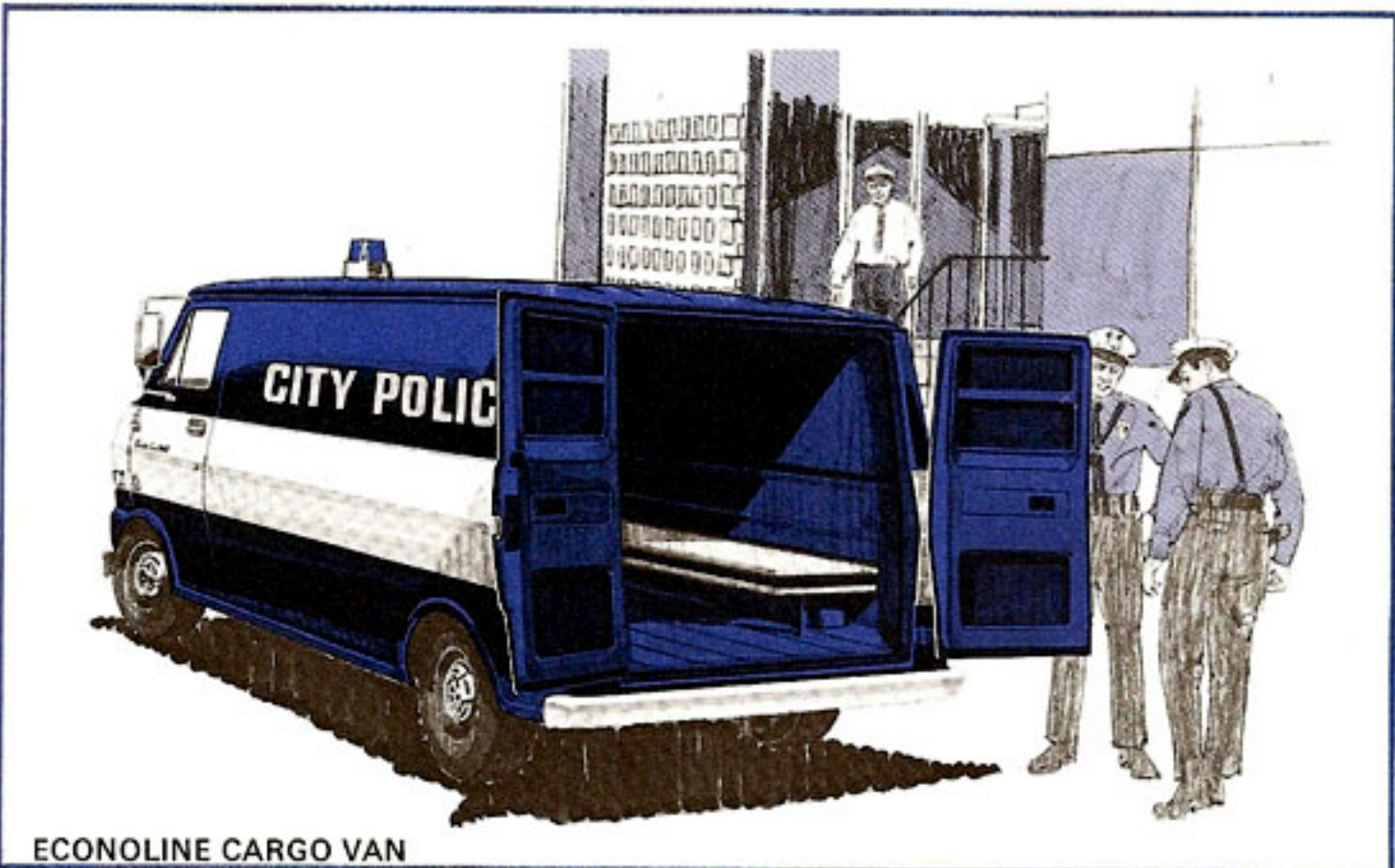
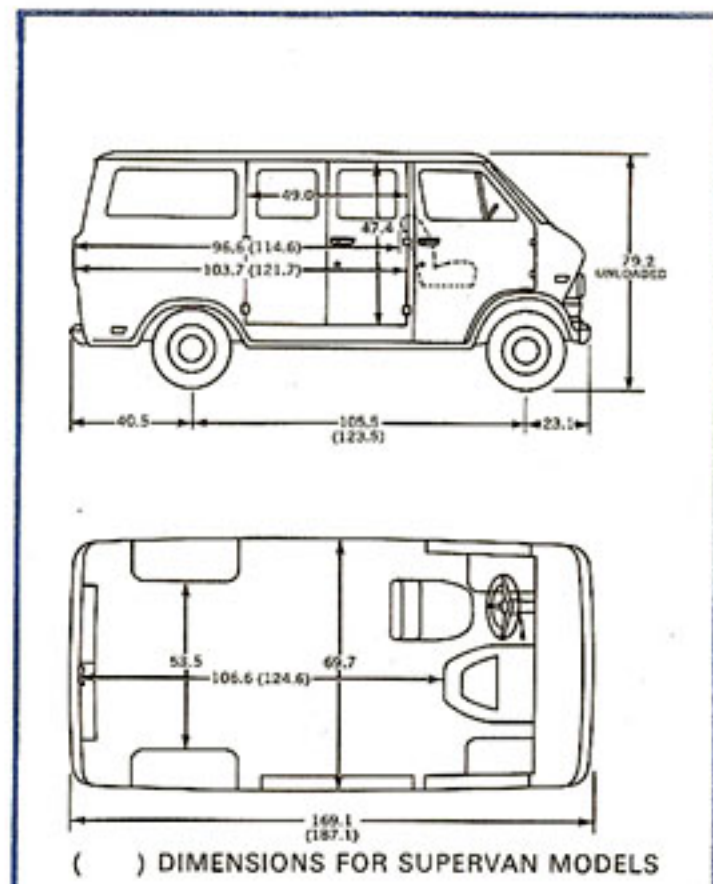

ECONOLINE CARGO VAN

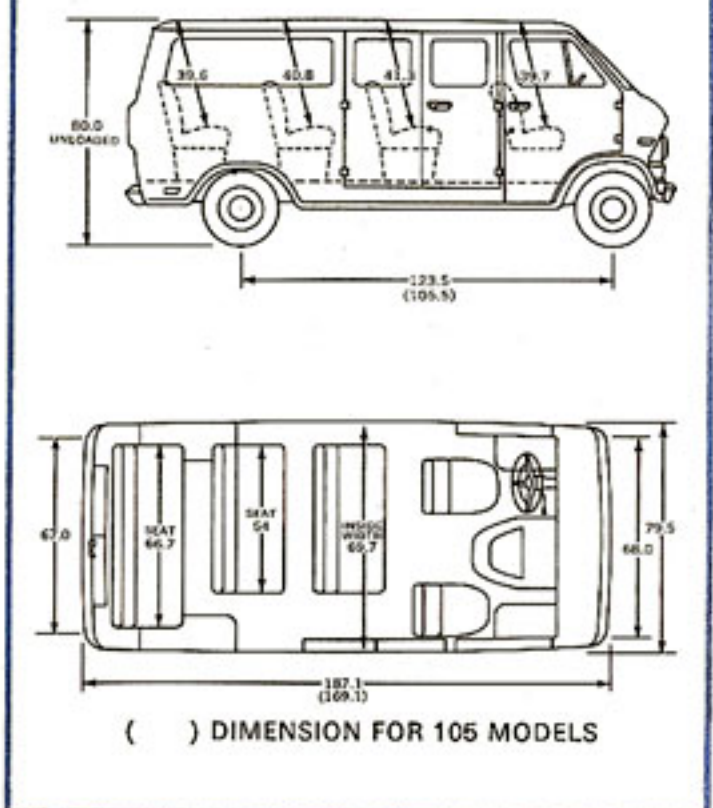

for maximum cargo security and for transporting prisoners. Display Vans have windows in the right side and rear door panels. They are well suited for conversion to field emergency units to carry stretchers. The Window Vans feature windows all around and may be used in a variety of police applications. Each body style is available on either of two wheelbases . . . the 105.5-inch regular or the 123.5-inch SuperVan.

Outstanding features are the "Twin-I-Beam" front suspension, an optional 302-c. i. d. V-8 engine, a substantial increase—up to 34 percent—in cargo space, easy access to the cargo area, and convenient outside access to the engine compartment for routine engine checks.

Three of these major improvements, increased cargo area, load space access, and outside access to the engine compartment, have been made possible by moving the engine 22 inches forward and 5 inches to the right compared to previous models. The use of Ford's "Twin-I-Beam" front suspension provides solid I-Beam durability and ruggedness with high quality ride of double-acting shock absorbers and coil spring suspension. This exclusive suspension system provides easier steering on turns, better stability on the highway, lower maintenance costs and longer tire life. The optional 302 V-8 is available to handle the maximum payloads up to 3,540 pounds, substantially higher than any in the industry. Wide-track axles, over 6½ feet wide front and rear,

contribute to greater vehicle stability and make the Vans and Club Wagons less susceptible to cross winds on the highway.

Increased durability and reliability necessary for effective police operation are built-in through the use of extra-large main structural members in the single-unit body-frame construction. Corrosion resistance is improved through the use of one-piece side panels. Unique, stronger floor pans are also used for *each* body length to avoid unnecessary floor joints.

No matter what your police department needs, transporting personnel, equipment or prisoners, or ambulance and rescue operations, there's a "better idea" Econoline Van or Club Wagon for you.

1969 FORD POLICE CAR SPECIFICATIONS

ENGINES

360-hp Police Interceptor V-8 — 428 cubic-inch displacement; 4.13" bore x 3.98" stroke; 10.5 to 1 compression ratio; premium fuel; 4-barrel carburetor with automatic choke; copper-lead main and connecting rod bearings; 5-quart oil capacity (including filter); and low-restriction dual exhausts (except station wagons). Special features include high-lift camshaft; high performance valve springs with internal dampers, and special hydraulic lifters; special alloy exhaust valves with chromed stems; free breathing air-cleaner plus other hi-speed and long life features.

320-hp V-8 (Cruiser) — 429-cubic-inch displacement; 4.36" bore x 3.59" stroke; 10.5 to 1 compression ratio; premium fuel; 2-barrel carburetor with automatic choke; canted valves with hydraulic lifters; precision molded crankshaft; copper-lead main and connecting rod bearings; 5-quart oil capacity (including filter); and single exhaust.

265-hp V-8 (Guardian) — 390-cubic-inch displacement; 4.05" bore x 3.78" stroke; 9.5 to 1 compression ratio; regular fuel; 2-barrel carburetor with automatic choke; free turn valves; precision molded crankshaft; copper-lead main and connecting rod bearings; 5-quart oil capacity (including filter); and single exhaust.

220-hp V-8 (Sentinel) — 302-cubic-inch displacement; 4.00" bore x 3.00" stroke; 9.5 to 1 compression ratio; regular fuel; 2-barrel carburetor with automatic choke; exhaust valve rotators; chrome valve tips and hydraulic lifters; precision-molded crankshaft; 5-quart oil capacity (including filter); and single exhaust.

150-hp Police Special Six (Deputy) — 240-cubic inch displacement; 4.00" bore x 3.18" stroke; 9.2 to 1 compression ratio; precision-molded crankshaft with seven main bearings; gear-driven camshaft; regular fuel; single-barrel carburetor with automatic choke; exhaust valve rotators; chrome-plated valve stem tips and hydraulic lifters; disposable cartridge-type full-flow oil filter; 5-quart oil capacity (including filter); and single exhaust.

CLUTCHES AND TRANSMISSIONS

Clutches in Police Packages have thick facings and high-capacity pressure-plate springs. All are semi-centrifugal. Face diameter and frictional area is 11.0" (113.1 square inches).

3-Speed Manual Transmission is fully synchronized in all forward speeds, has hardened and shot-peened alloy-steel helical gears, and forged bronze synchronizers. Police Package with manual transmission includes heavy-duty shift linkage.

SelectShift Cruise-O-Matic Drive is a required option in the Interceptor and Cruiser Police Package and is optional in the Guardian, Sentinel or Deputy Police Packages. The Interceptor Cruise-O-Matic is specially-calibrated for up-shifts at higher RPM.

REAR AXLE

Police Package Heavy-Duty Axle is semi-floating type with deep-offset hypoid gears and straddle-mounted drive pinion. Also included are higher capacity wheel bearings with larger diameter axleshafts. Lubricator-fitted universal joints. For axle ratios see page 11.

ELECTRICAL

The electrical system is 12-volt with a 42-ampere alternator. Interceptor and Cruiser Police Packages have 80 ampere-hour 78-plate heavy-duty battery. Guardian, Sentinel, and Deputy Police Packages have 70-ampere hour 66 plate heavy-duty battery. Weatherproof ignition system with Static-Ban constant-resistance wiring and air-cooled distributor points; positive-engagement starter.

SUSPENSION

Front—Wide 63-inch tread; ball-joint short and long arm suspension with drag strut stabilized lower arm anchored in anti-harsh compliant rubber bushings. Ball joints packed with 36,000-mile lubricant retained by full-life seals. Rubber-bushed stabilizer bar helps control sway on turns. Tapered roller wheel bearings with 30,000-mile check interval (repack as required). Specially calibrated shock absorbers with all-weather fluid for better year-round control.

Police Package—Same as above with the maximum handling components which includes heavy-duty coil springs, shock absorbers, front stabilizer bar, and heavy-duty lower front suspension arms.

Rear—Wide 64-inch tread. Three-link coil spring system with long and short mounting-link arrangement to control dive and squat tendencies in braking and acceleration. Lateral track bar centers axle, resists body sway and roll on turns.

All links and track bar rubber-bushed for smooth, quiet operation. Shock absorbers sea-leg-mounted to resist body side-shake, have all-weather fluid for more uniform ride control.

Police Package—Have heavy-duty coil springs and shock absorbers.

STEERING

Precision-control, low-friction recirculating-ball type steering gear with anti-friction bearings throughout for easier steering. Flexible coupling in steering shaft insulates steering wheel; symmetrical linkage with nylon bearings in tie rod and pitman arm pivots packed with 36,000-mile lubricant retained by full-life seals. Overall steering ratio 30.8 to 1; with power steering, 21.8 to 1.

BRAKES

Dual hydraulic system with dual master cylinders provides independent brake system to front and rear wheels. Power front disc/heavy-duty rear drum brakes included in the Interceptor Police Package and optional on others. Police Package Heavy-Duty Brakes, standard on the Cruiser, Guardian, Sentinel and Deputy, have 225 square-inch riveted linings and specially grooved 11" diameter composite drums for maximum cooling and fade resistance. Foot operated parking brake with hand release under panel.

TIRES

4-ply rating black tubeless tires with nylon cord. Safety-type 6" rims. * Basic sizes: 8.15 x 15 (8.15 x 15 high-performance on Interceptor Package). All station wagons have 8.55 x 15 tires.

*8.55 x 15 supplied with 6.5" rims.

DIMENSIONS

Overall length 214" (sedans), 217" (wagons); width 79.4"; height 55.1" (sedans), 56.8" (wagons); wheelbase 121", tread 63" front 64" rear; fuel 24 gallon (sedan), 23 gallon (wagons); sedan trunk luggage volume 18 cubic feet; wagon cargo volume 96.2 cubic feet.

The illustrations and product information contained herein were current at the time this publication was approved for printing. However, the Ford Motor Company reserves the right to change specifications, designs, models or prices without notice and without liability for such changes.

FORD 