

BUDGET PRINT
FOR
SUCCESS

A Glimpse of Pontiac Excitement for 1980

This striking new grille
is where Bonneville's startling new
lower, longer look for 1980 starts. And
under the hood of our Bonneville Brougham
you can order an
available diesel
V-8 engine,*
the first
Pontiac's
ever
offered.

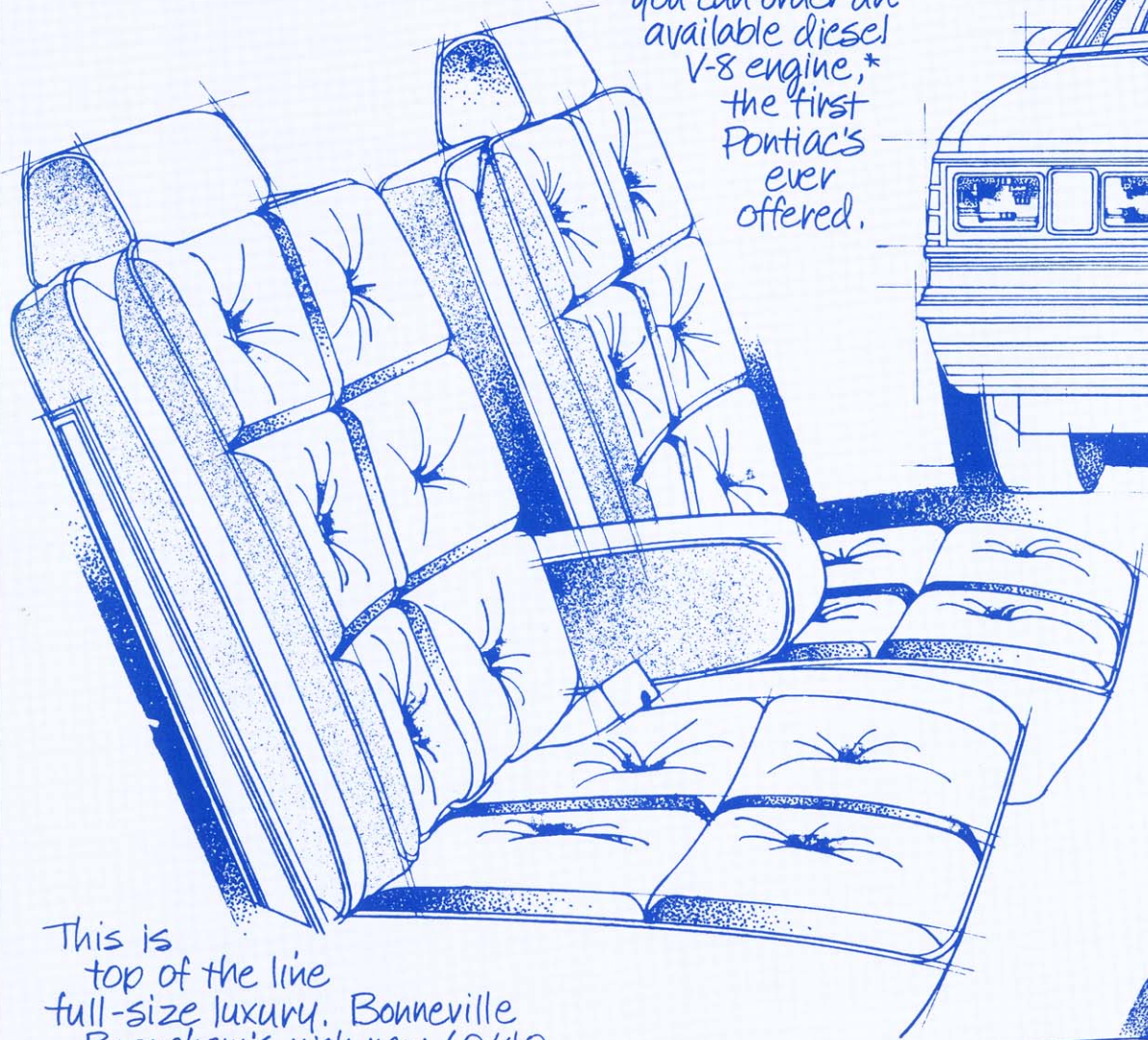
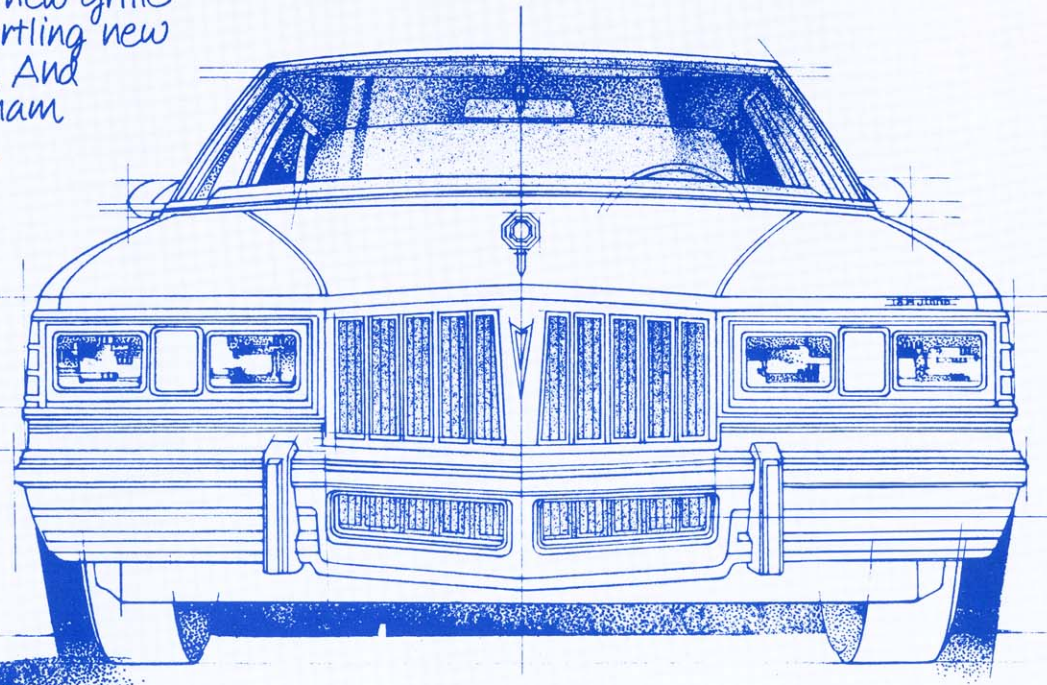

This is
top of the line
full-size luxury. Bonneville
Brougham's rich new 60/40
notchback seating, now available with
genuine leather in the seating area.

Cushion the Coupe's
formal new roofline
in available
padded
vinyl.

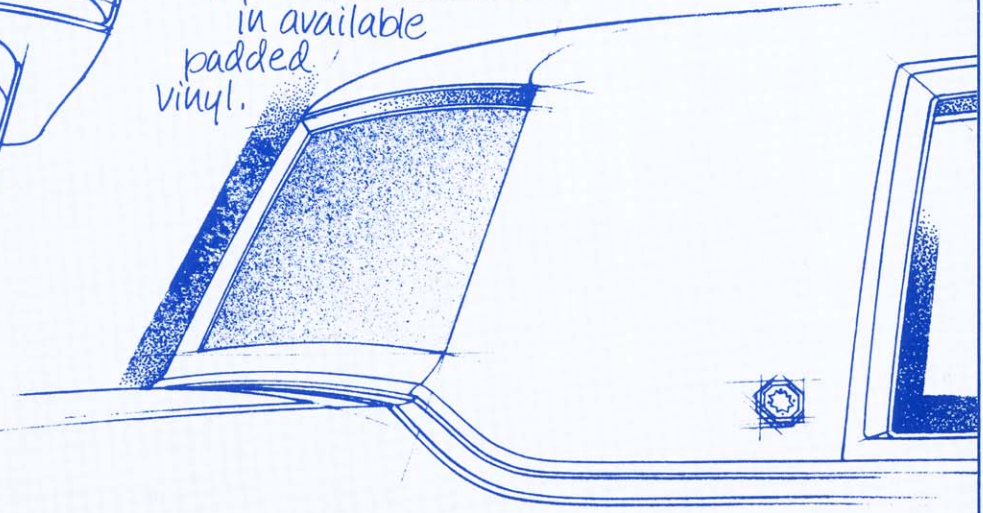

Bonneville A whole new dimension to full-size enjoyment.

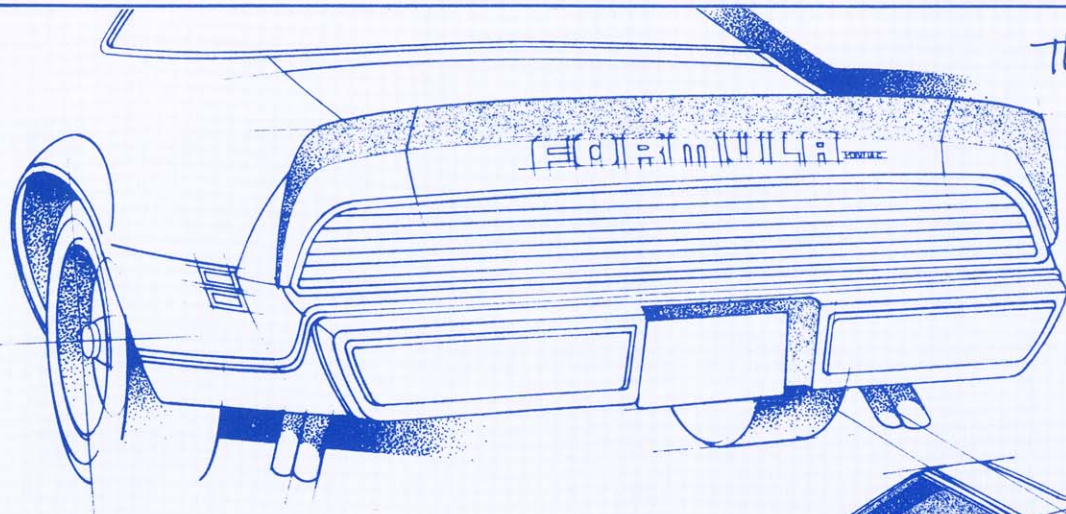

This exclusive blacked-out tail module is the last thing you'll see as the world's first turbocharged V-8* production cars of the '80s head down the highway. (Blacked-out tail module and available Turbo V-8 only on Trans Am and Formula Firebird.)

* Pontiacs are equipped with GM-built engines produced by various divisions. See your dealer for details.

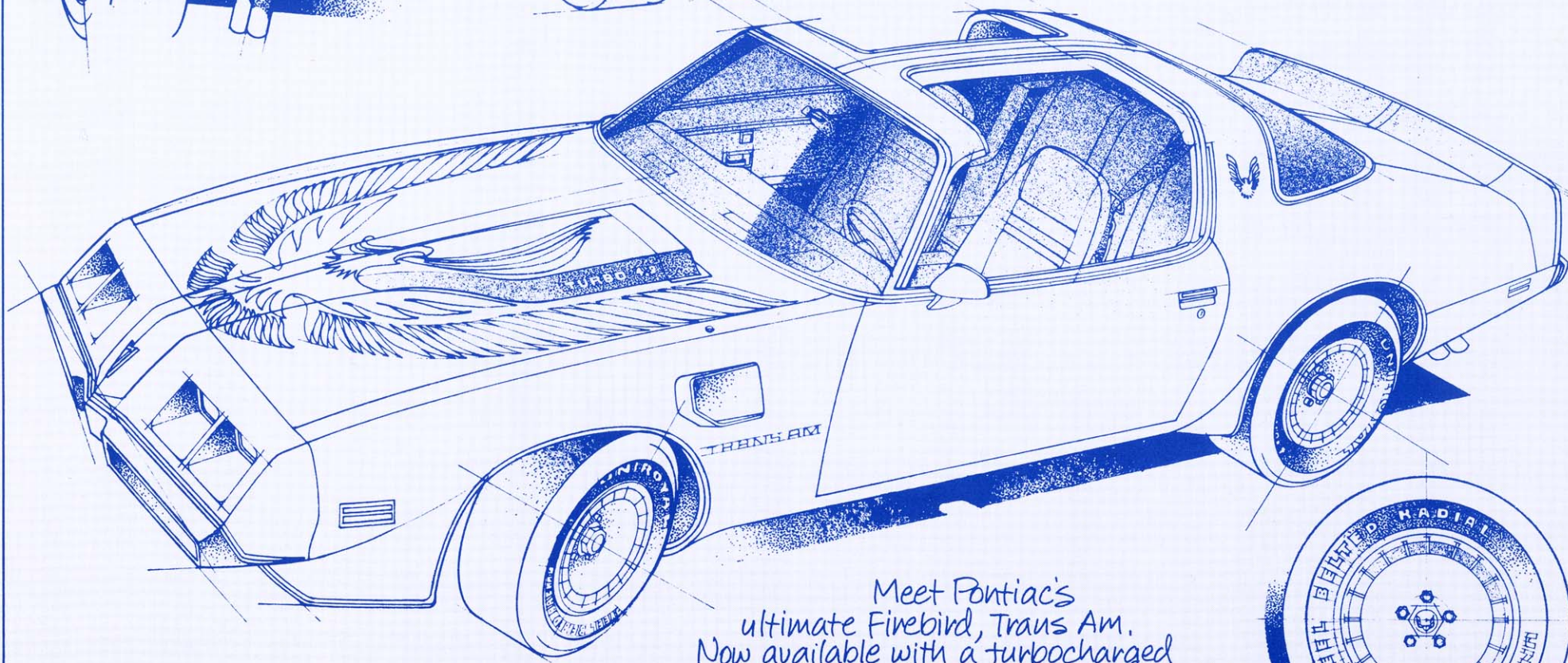

Meet Pontiac's ultimate Firebird, Trans Am. Now available with a turbocharged V-8 for 1980, it's a lean, radial-tuned road machine that turns a head every time it turns a corner. (Turbo V-8 not available in California.)

Firebird A fabulous new era of performance begins.

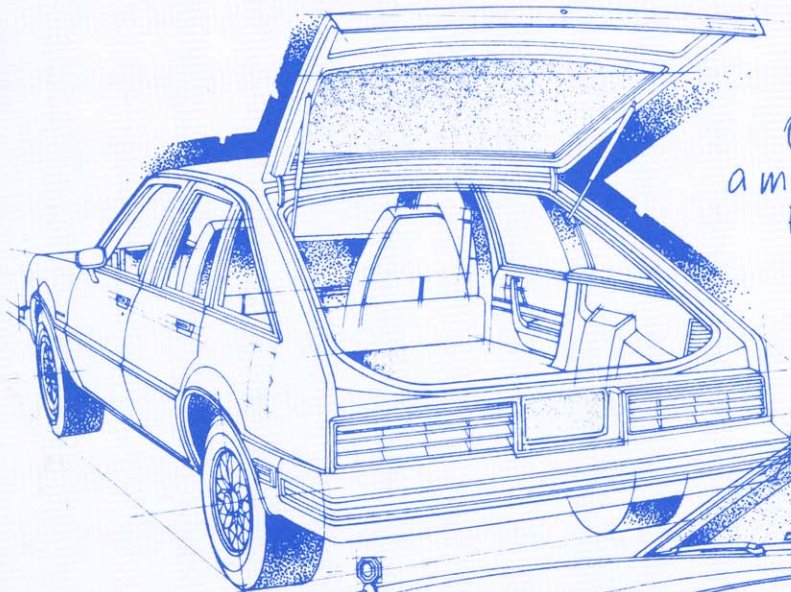

Our all-new Phoenix is so roomy inside that it's classified as a mid-size car, though it's no bigger outside than most compacts! For example, this functional yet fun-loving Phoenix Hatchback offers over 40 cu. ft. of cargo space with its rear seat down.

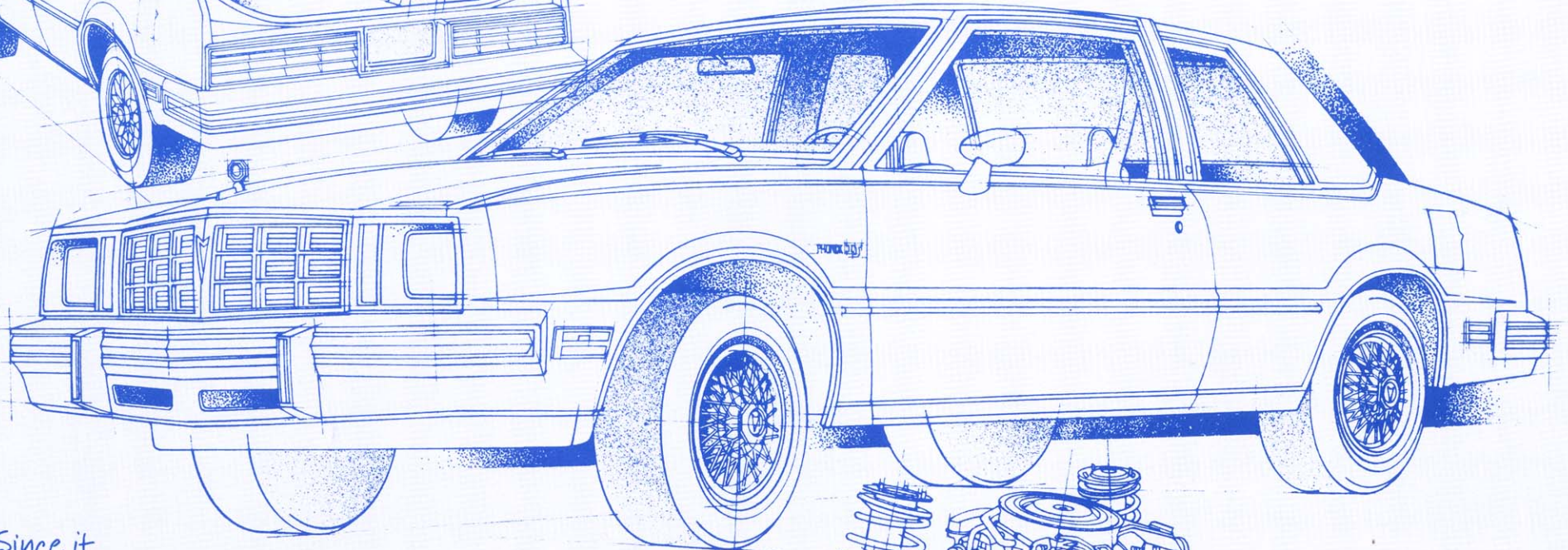

Since it leaped off the drawing boards into showrooms last spring, Phoenix has been wowing America with an amazing combination of advanced engineering, passenger roominess and comfort, and Pontiac style.

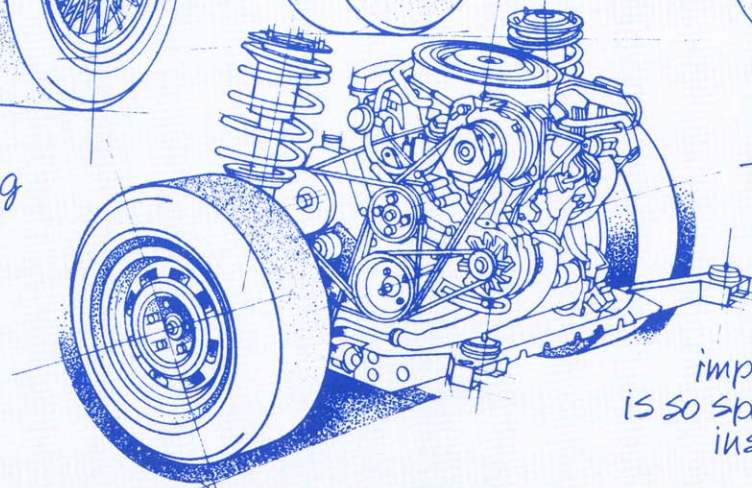

The engine of our first front-wheel drive Pontiac sits sideways, one important reason Phoenix is so space-efficient inside and out.

Phoenix Front-wheel driving excitement for a bold new decade.

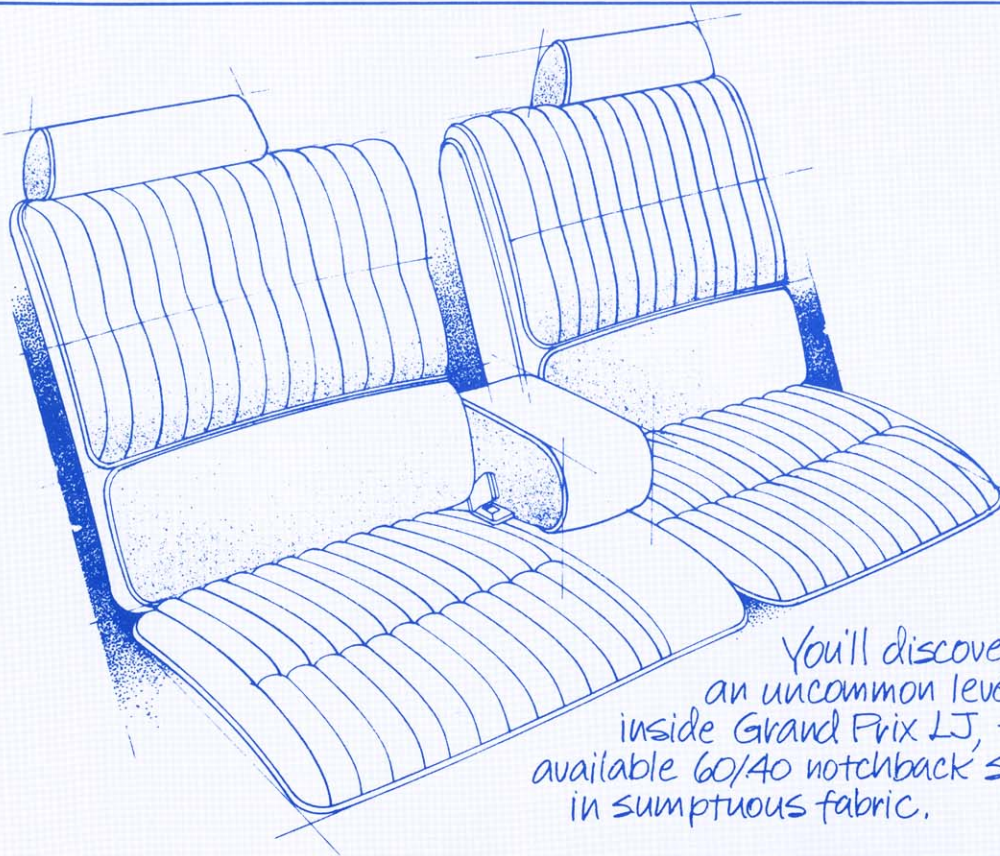

You'll discover an uncommon level of luxury inside Grand Prix LJ, featuring these available 60/40 notchback seats upholstered in sumptuous fabric.

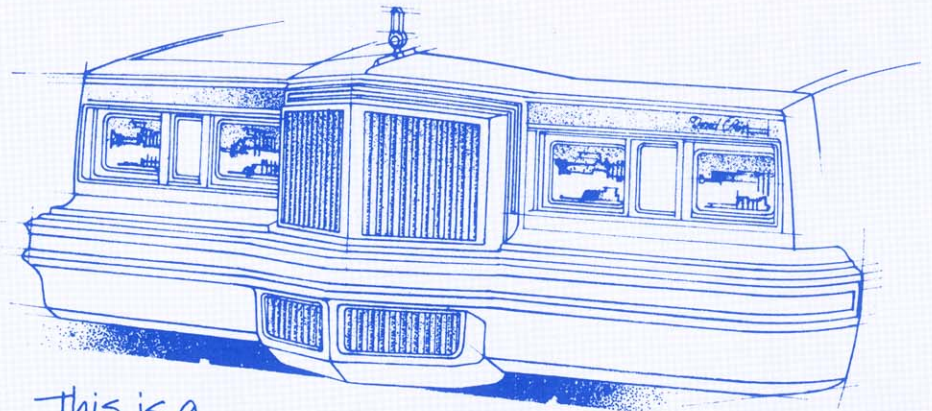

This is a distinctive new 1980 Pontiac Grand Prix coming at you. Note the commanding new vertical grille. And those are Pontiac's available tungsten quartz halogen high-beam headlamps on either side.

You can accent the clean, uncluttered lines of our new Pontiac Grand Prix with an available double two-tone paint treatment.

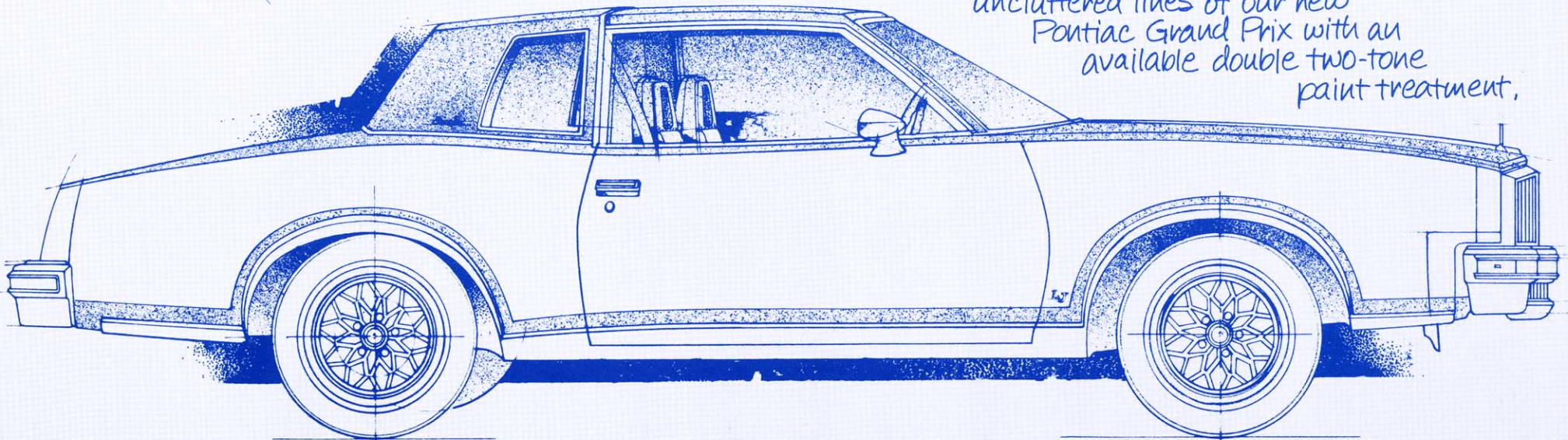

Grand Prix An uncommonly good year for Grand Prix luxury.

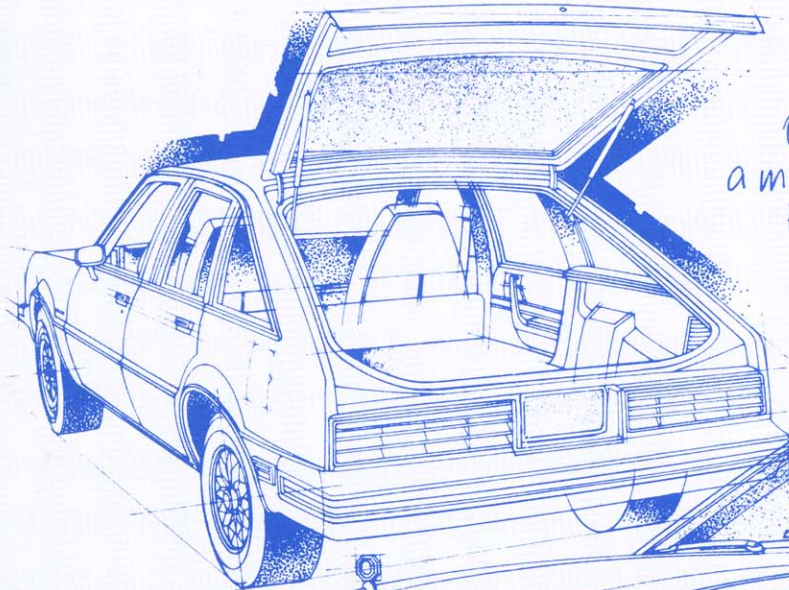

Our all-new Phoenix is so roomy inside that it's classified as a mid-size car, though it's no bigger outside than most compacts! For example, this functional yet fun-loving Phoenix Hatchback offers over 40 cu. ft. of cargo space with its rear seat down.

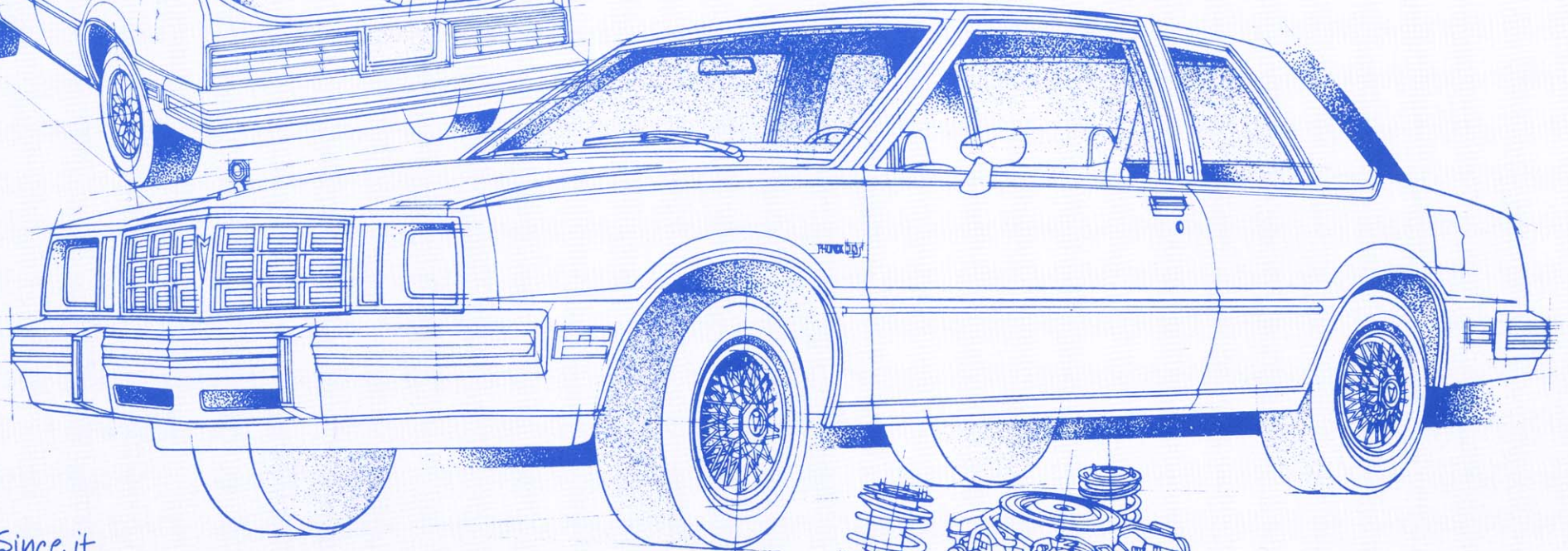

Since it leaped off the drawing boards into showrooms last spring, Phoenix has been wowing America with an amazing combination of advanced engineering, passenger roominess and comfort, and Pontiac style.

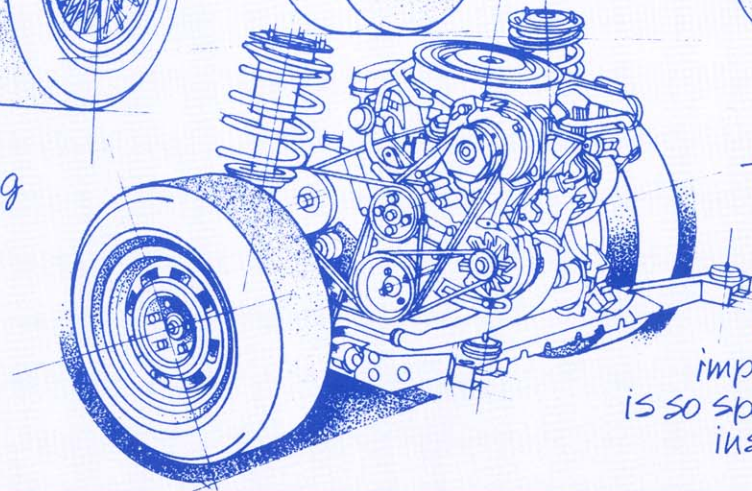

The engine of our first front-wheel drive Pontiac sits sideways, one important reason Phoenix is so space-efficient inside and out.

Phoenix Front-wheel driving excitement for a bold new decade.

This 1980 Sunbird Sport Hatch is one nifty little subcompact, whether you spoil yourself with the available rear deck spoiler or not.

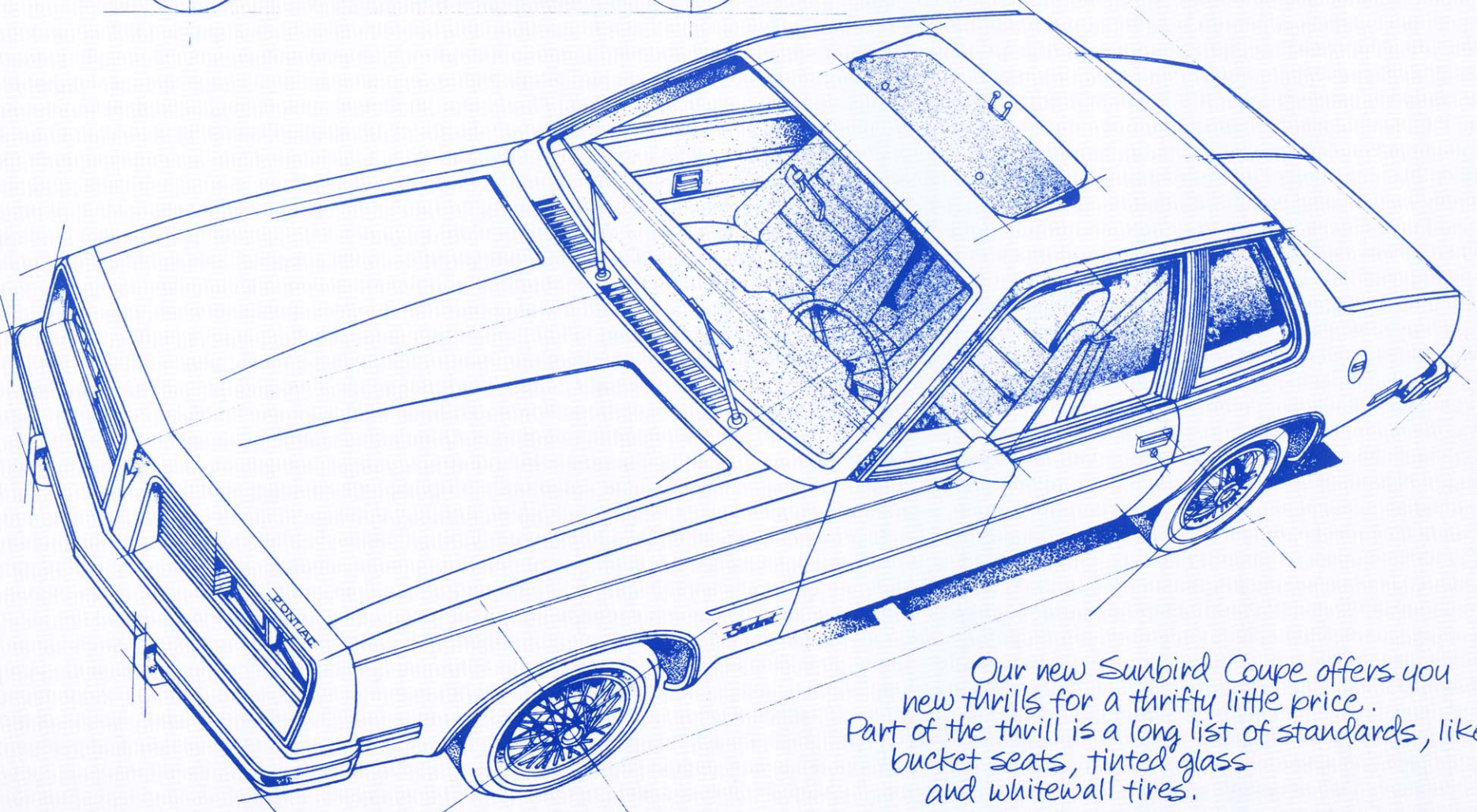
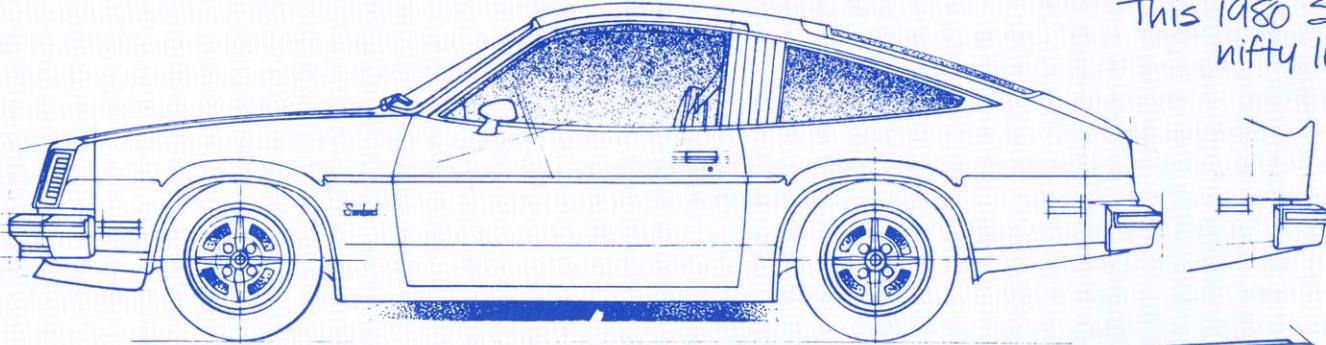

Our new Sunbird Coupe offers you new thrills for a thrifty little price. Part of the thrill is a long list of standards, like bucket seats, tinted glass and whitewall tires.

Sunbird More than a little Pontiac excitement for 1980!

