

1981 OLDSMOBILE

CUTLASS • CUTLASS CRUISER • OMEGA

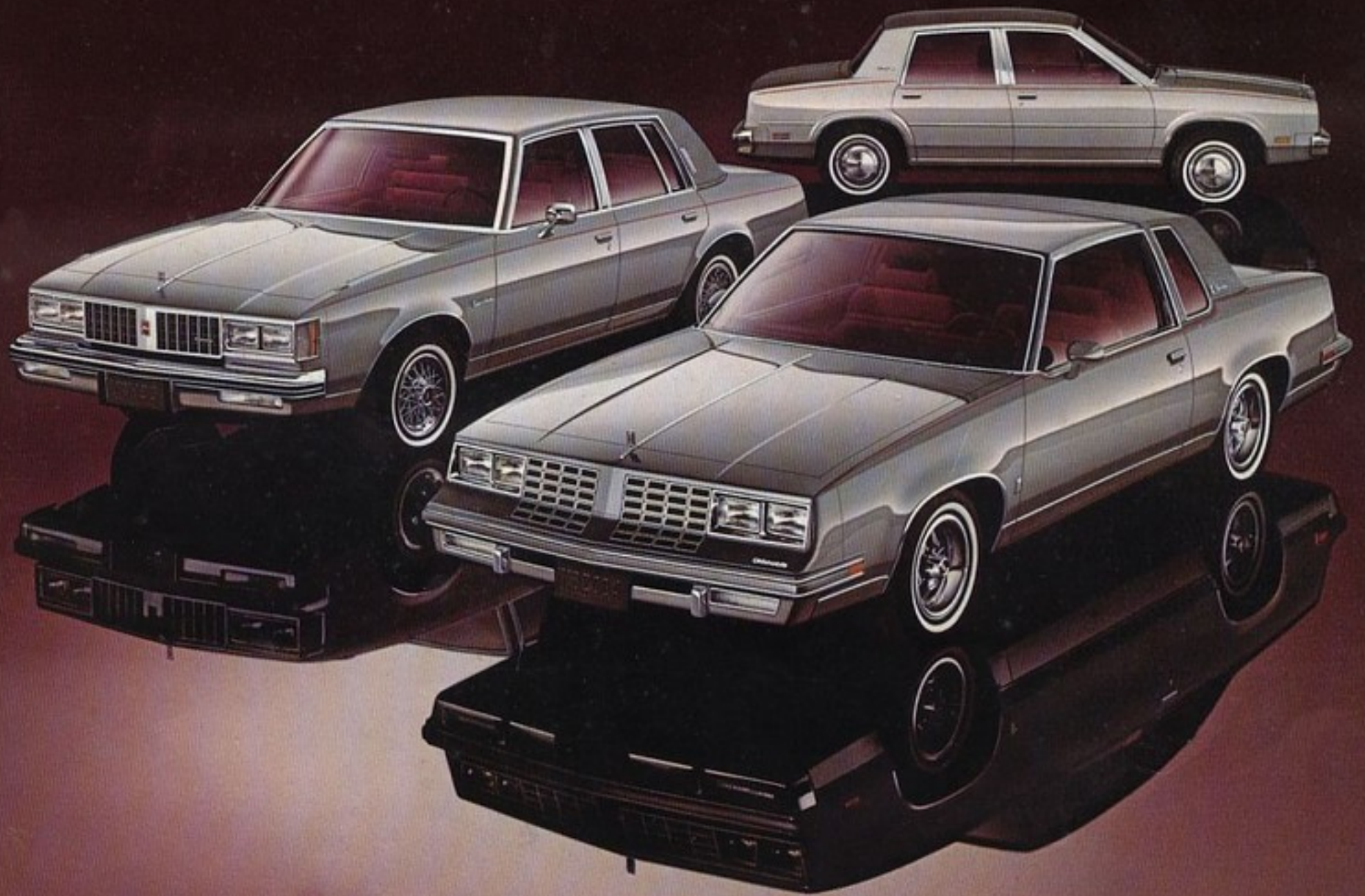

Oldsmobile

We've had one built for you.

Today, more than ever, America is looking for quality in the cars it buys.

That's why we think you're going to like what you see in the 1981 Oldsmobiles.

Oldsmobile's commitment to value and quality goes back farther than any car maker in America—to 1897. In fact, the Oldsmobile Motor Vehicle Company was founded with this single-minded purpose: "...to build one carriage in as nearly perfect a manner as possible..."

We've been at it ever since—offering quality and total value.

And this is exactly what American car buyers want these days. You've made us the third best-selling American nameplate, year after year. You've made Cutlass America's favorite car—of any size, any price, import or domestic. Over the past five years, you've made Delta 88 the fastest-growing full-size car. And more recently, you've made Oldsmobile America's number one seller of diesel-powered automobiles.

For 1981, America is also looking for fuel economy. And our new Oldsmobiles are ready to meet your needs there, too.

The accompanying Engine Supplement Sheet contains the EPA estimates for all our cars, plus highway estimates and range estimates for city and highway. We think you'll find them impressive.

To achieve optimum levels of fuel efficiency, a number of improvements have

been engineered into our 1981 models—expressly to help conserve energy.

Computer Command Control. *On all standard 1981 gasoline engines. It helps reduce exhaust emissions while allowing good fuel efficiency. Its electronic control module monitors engine speed, coolant temperature and oxygen in the exhaust. This data is analyzed at thousands of calculations per second, then the carburetor is adjusted to control combustion—so the catalytic converter can minimize emissions. Result? We're helping to clean the air, while providing good fuel economy.*

Torque converter clutch. *It's standard in the automatic transmissions on Cutlass, Delta 88, Ninety-Eight and all Cruiser models. It engages at cruising speeds to increase the efficiency of power transfer from engine to road, and prevents fuel-wasting slippage.*

New four-speed overdrive automatic transmission. *Now standard on Ninety-Eights, Custom Cruisers, and available on Delta 88s with 4.3 and 5.0-liter V8s. The .67 ratio overdrive fourth gear reduces engine RPMs at highway speeds, and that contributes to impressive fuel economy.*

Low drag front disc brakes. *Now standard on all 1981 Delta 88, Ninety-Eight and Omega models. This feature helps reduce fuel-consuming friction.*

Diesel V8 economy. *Oldsmobile,*

America's number one seller of diesel-powered cars, is offering the fuel-saving benefits of a 5.7-liter diesel engine—with new roller hydraulic lifters and extended service intervals. The diesel V8 is available in 19 models, including all Cutlass, Cruiser, Delta 88, Ninety-Eight and Toronado models.

Easy-roll tires. *All 1981 Oldsmobile models will include easy-roll tires as standard equipment. These tires are designed to help reduce fuel-consuming roll resistance and contribute to fuel economy.*

There's much more to like about the 1981 Oldsmobiles, as you will find by studying these pages, model by model. We're confident we have an Oldsmobile that's built for you—but which one depends on your needs and preferences.

So seek it out. Drive it proudly. Whether you buy it or lease it, our commitment to quality and value rides with you every mile of the way.

Table of contents:

Cutlass Coupes	Pages 3-9
Cutlass Sedans	10-13
Cutlass Cruisers	14
Cutlass Cruiser Facts/Figures	15
Cutlass Facts/Figures	16-17
Omega Coupes/Sedans	18-23
Omega Facts/Figures	24-25
Options/Accessories	26-27
Complete Olds Line	28

A word about this catalog: *We have tried to make this catalog as comprehensive and factual as possible and we hope you find it helpful. However, since the time of printing, some of the information you will find here may have been updated. Also, some of the equipment shown or described throughout*

this Oldsmobile catalog is available at extra cost. Your dealer has details and, before ordering, you should ask him to bring you up to date. The right is reserved to make changes at any time, without notice, in prices, colors, materials, equipment, specifications and models. Check with your Oldsmobile dealer

or complete information.

word about engines: *Oldsmobiles are quipped with GM-built engines produced by various divisions. See your dealer for details. Please refer to the "Engine Supplement Sheet" provided to your dealer for engine source and EPA mileage estimates.*





CUTLASS

Classic looks and total value make it an American favorite, year after year.



CUTLASS SUPREME BROUGHAM

With luxury you would expect in a more expensive car.



CUTLASS CALAIS: New looks and excitement for the grand touring experience.

Bold new looks for those classic Cutlass coupes! Over the last six years, more mid-size buyers have chosen Cutlass than any other car.

Styling leadership is part of the reason. And now, that styling is more beautiful than ever. Clean,

sleek and aerodynamic—to help America's best-selling coupes slip through the wind with even greater ease than before. But what makes Cutlass coupes so popular isn't just looks. It's total value!

It's the fuel efficiency of a smooth-

firing V6 engine that offers the kind of mileage you need today.* Or an available fast-starting diesel V8 for even better fuel economy.*

It's quality engineering for space efficiency and comfort, with impressive head- and legroom, front and

back. Stretch out and relax.

It's a trim size and smooth, quiet ride that makes the Cutlass coupe a pleasure to drive. Agile in city traffic and easy to park, too.

It's built-in value—with power front disc brakes, power steering,



CUTLASS SUPREME: America's favorite Cutlass for flair, value and price.

automatic transmission, Flo-Thru ventilation, comfortable full-foam seats, high-energy ignition, extensive anti-corrosion measures, new easy-roll steel-belted radial-ply tires and more. All standard. All at a very attractive price.

It's Cutlass versatility, a quality that makes each Cutlass coupe a different car to different people. So ... which coupe is built for you? **Cutlass Supreme Brougham.** The most luxurious Cutlass coupe of all — with deep tufted, loose-pillow-

look seats in rich velour. The front seat is divided, with individual controls and center armrest, standard. **Cutlass Calais.** Sporty. A grand touring experience — with reclining front bucket seats, custom sport steering wheel, gauges, powerful

halogen highbeam headlamps and special suspension — all standard. **Cutlass Supreme.** It's the easiest way of all to enjoy the beauty, quality and solid value of a Cutlass. No wonder it's become the most popular Cutlass. Ever!

*See EPA mileage estimates in accompanying Engine Supplement Sheet.



CUTLASS BROUGHAM SEDAN

Brougham luxury in a sedan for today.



CUTLASS LS SEDAN: Practical elegance makes it the most popular Cutlass sedan.

Those formal Cutlass sedans: a big hit right from the start. Last year, Oldsmobile introduced new Cutlass sedans for people who wanted impressive fuel economy,* plus sedan room and comfort. Well, they quickly became the best-selling sedans in

Olds Cutlass history. Those formal sedans are back—and they're more practical than ever.

With great looks and sedan convenience, they're right in tune with the times. Inside, ample head- and legroom, front and back. Step to the

rear and you find a trunk that is definitely vacation-size. So bring on the luggage and golf clubs.

But behind the wheel is where you'll like it best. Seats are full-foam. And very comfortable. The ride is smooth and quiet—with

computer-selected springs and extensive sound-absorbing materials. So relax and enjoy.

Great sedans in the Oldsmobile tradition. But how's the mileage? Impressive! With a smooth-firing V6 engine that comes standard.*



CUTLASS SEDAN: A nice surprise for people who think they can't afford Cutlass quality.

Or with the available fast-starting diesel V8 for even better mileage.*

With the standard power brakes, power steering, automatic transmission (except Cutlass Sedan), extensive anti-corrosion measures and Body by Fisher—you've got the

total value that's making Cutlass sedans so popular. Take a good look. Because one is built for you. **Cutlass Brougham Sedan.** Luxurious. That's Brougham—with loose-pillow-look seats in rich, soft velour. The front seat is divided,

with individual controls and center armrest, standard.

Cutlass LS Sedan. The most popular Cutlass sedan—because it is both impressively elegant and sensibly practical—at the same time! Quality knit fabric or supple vinyl and

front center armrest, standard.

Cutlass Sedan. A nice surprise today is knowing what you want in a car—and finding it's affordable. That's our lowest-priced Cutlass sedan. It just might set a new standard for solid mid-size value.

*See EPA mileage estimates in accompanying Engine Supplement Sheet.



CUTLASS CRUISER BROUGHAM—First, it's an Oldsmobile. Then, it's a wagon.

The Cutlass cruisers: the elegant, comfortable and smooth-riding wagons. Why give up what you like in a car just to get the utility and convenience of a wagon? You don't have to. Because Cutlass cruisers give you the room, comfort, agility

and ride you like in an Olds, plus the space and utility of a wagon. And the fuel economy* is impressive — with standard V6 or available V8s, including a fast-starting diesel. **Cutlass Cruiser Brougham.** A wagon with luxury touches. Front

center armrest and fully carpeted cargo floor, standard. The upholstery comes three ways: all-vinyl, all-fabric or fabric up front, vinyl in back — your choice. **Cutlass Cruiser.** The lowest priced way to get Olds quality in a wagon.

Handsome, durable, easy-care vinyl upholstery is standard.

1. Standard Cutlass Cruiser vinyl interior. 2. Functional split tailgate. 3. Cutlass Cruiser. 4. Roof rack and air deflector, available. 5. Hidden compartment/spare tire storage.



CUTLASS CRUISER



A closer look at what makes Olds Cruisers great wagons...

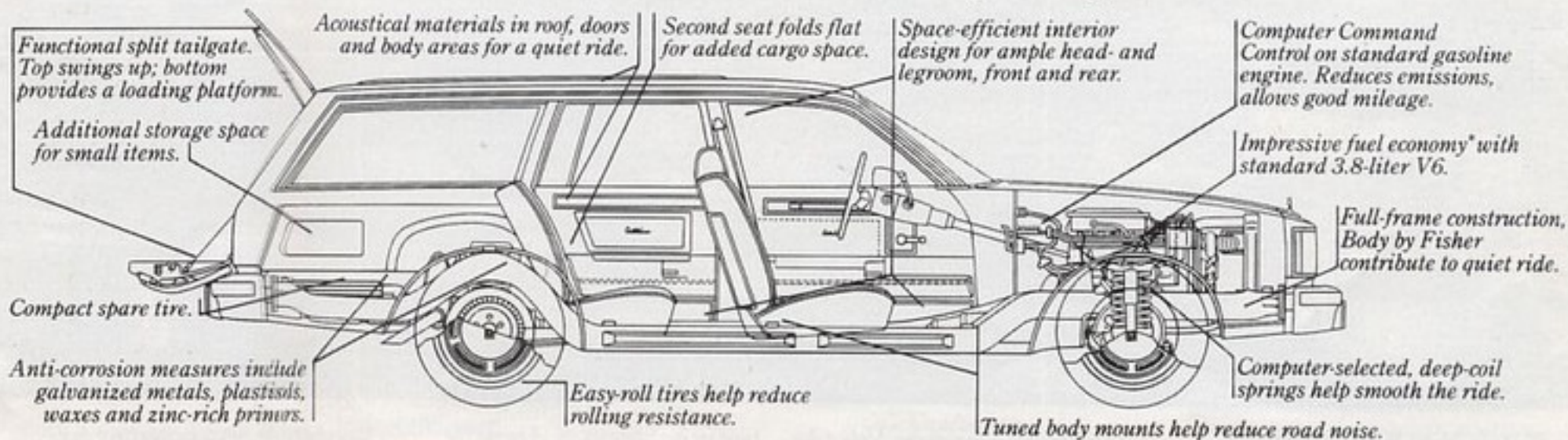

CUTLASS CRUISER POWER TEAMS*

Standard engine:

Liter/CID/Type 3.8/231/V6
Carburetion 2-bbl

Available engines:

Liter/CID/Type 4.3/260/V6
Carburetion 2-bbl

Liter/CID/Type 5.0/307/V8

Carburetion 4-bbl

Liter/Type 5.7/Diesel V8

Standard transmission:

Automatic Column-mounted shifter

Fuel capacity, gasoline (gal.) 18.2

Fuel capacity, diesel (gal.) 18.2

DIMENSIONS (Cutlass Cruiser)

Overall length (in.) 198.2

Wheelbase (in.) 108.1

Headroom, front (in.) 38.8

rear (in.) 38.8

Hiproom, front (in.) 52.2

rear (in.) 55.6

Shoulder Room, front (in.) 56.7

rear (in.) 57.1

Legroom, front (in.) 42.8

rear (in.) 35.9

Maximum cargo volume (cu. ft.) 71.8

Floor length

from back of floor surface

to end of floor surface 81.2

Floor length

from back of second seat

to end of floor surface 49.7

Minimum horizontal distance

from top rear of front seat

back to inside of tailgate at belt 72.9

Minimum distance between

wheelhouses at floor level 43.6

Rear-end opening width at belt 51.7

Maximum height of rear

opening, tailgate open 27.6

Maximum cargo height 29.8

*See EPA mileage estimates in accompanying Engine Supplement Sheet.



Cutlass facts, figures, features and options. 1. Cutlass instrument panel in swirled walnut vinyl veneer. 2. Available wheel trim: (A.) Cast-aluminum sport wheel. (B.) Simulated wire. (C.) Super-stock III with matching body color.

(D.) Deluxe with matching body color. (E.) Deluxe with chrome. 3. Luggage capacity? Voluminous. There's 16.3 cubic feet of it in sedans, 16.8 in coupes. 4. Removable tinted glass roof panels available on coupes for added fun, sun and air. No reduc-

tion in headroom. 5. Available gage package to help keep you informed, standard on Calais. 6. Distinctive exterior opera lamps. A very elegant touch, available on both Brougham and LS Sedans. 7. Smooth-firing 3.8-liter V6 engine,

standard. 8. Quick-starting 5.7-liter diesel V8 available for impressive mileage.* 9. Sporty bucket seats are available in Cutlass coupe models. 10. Available custom sport steering wheel with padded grip, standard on Calais.

CUTLASS STANDARD EQUIPMENT

Chassis and body:

■ Computer Command Control ■ High-energy ignition system ■ Power steering ■ Quick-cooling power front disc brakes ■ Computer-selected full coil springs, front and rear ■ Tuned body mounts ■ Recessed windshield wipers ■ Compact spare tire ■ Space-efficient trunk ■ Bumper guards, front and rear (Cruiser, front only) ■ Torque-beam frame ■ Extensive rust-resisting treatments ■ Anti-corrosion front fender liners ■ Maintenance-free Freedom II battery ■ Delcotron ■ Easy-roll tires ■ Automatic transmission with torque converter clutch (except Cutlass Sedan with standard manual transmission) ■ Dual fluidic windshield washers.

Interior:

■ Full-foam seat construction ■ Armrests, front and rear ■ Cut-pile carpeting, wall-to-wall ■ Simulated Butterfly Walnut grain instrument panel ■ Automatic courtesy lamps, door actuated ■ Cigar lighter ■ Inside day/night rearview mirror ■ Interior-operated hood release ■ Flo-thru ventilation ■ One-piece sound-absorbing headliner ■ Front seat head restraints ■ Front and rear seat belts.

STANDARD EQUIPMENT BY MODEL

Cutlass Sedan, Cruisers:

■ Engine, 3.8-liter (231 CID) V6, 2-bbl. ■ Sedan transmission, 3-speed fully synchronized, manual floor shift. Cruiser transmission, fully automatic, column shift ■ Bench seats, cloth or vinyl (Cruiser, vinyl only) ■ Tires, P185/75R14 glass-belted radial-ply blackwall (Cruiser, P195/75R14) ■ Moldings: bright roof drip and wheel-opening (Cruisers).

Cutlass Supreme, LS Sedan:

■ Engine, 3.8-liter (231 CID) V6, 2-bbl. ■ Transmission, automatic ■ Custom sport front bench seat with center armrest, choice of cloth or vinyl ■ Tires, P195/75R14 steel-belted radial-ply blackwall ■ Moldings: bright rocker panel, wheel-opening and roof drip ■ Deluxe steering wheel.

Supreme Brougham, Brougham Sedan:

■ Engine, 3.8-liter (231 CID) V6, 2-bbl. ■ Transmission, automatic ■ Divided bench front seat with individual controls, velour cloth ■ Tires, P195/75R14 steel-belted radial-ply blackwall ■ Moldings: belt reveal with pillar applique (coupes), rocker panel (sedans), wheel-opening, wide lower body (coupes) and roof drip ■ Full wheel discs ■ Deluxe steering wheel.

Cutlass Calais:

■ Engine, 3.8-liter (231 CID) V6, 2-bbl. ■ Transmission, automatic ■ Rallye gage instrument cluster ■ Ride and handling package ■ Reclining front bucket seats, cloth or vinyl ■ Halogen high beam headlamps ■ Tires, P195/75R14 steel-belted radial-ply blackwall ■ Moldings: wheel-opening, wide lower body, roof drip, belt reveal and pillar applique ■ Special painted wheel discs ■ Custom sport steering wheel.

Cutlass Cruiser Brougham:

■ Engine, 3.8-liter (231 CID) V6, 2-bbl. ■ Transmission, automatic ■ Custom sport front bench seat with center armrest, choice of cloth or vinyl. Or choose cloth in front, vinyl in back ■ Tires, P195/75R14 glass-belted radial-ply blackwall ■ Moldings: rocker panel, wheel-opening and roof drip ■ Bright wheel hubcaps ■ Deluxe steering wheel.

CUTLASS AVAILABLE EQUIPMENT

- Six-way power seat
- Reclining seat back, passenger side manual
- Power door locks
- Tinted windows
- Power side windows
- Bucket seats (coupes)
- Divided front seat with center armrest and individual controls
- Power trunk-lid release
- Removable roof panels (coupes)
- Electric sliding metal or glass sunroof (coupes). Reduces headroom slightly
- Landau or full vinyl roof covering
- Pulse wiper system
- Electric rear window defogger
- Air conditioner, Four-Season or Tempmatic
- Remote control outside rearview mirror, driver or passenger side
- Dual sport mirrors, driver side with remote control, passenger side available
- Sport console (Supreme coupe)
- Illuminated visor vanity passenger mirror
- Paint stripes
- Limited slip differential
- Cruise Control with resume feature
- Custom sport steering wheel (standard on Calais)
- Tilt-Away steering wheel
- Tungsten halogen high beam headlamps (standard on Calais)
- Trip odometer (standard on Calais)
- Instrument gage cluster (standard on Calais)
- Radio and tape players (see page 26)
- Automatic power front fender antenna
- Electric clock (digital or regular)
- External lamp monitor, front and rear
- Reminder group package
- Convenience group package
- Special duo-tone paint scheme
- Deluxe seat belts
- Hidden storage compartment lock (Cruisers)
- Roof rack and air deflector (Cruisers)
- Exterior opera lamps (Brougham, LS Sedan)
- Dome and dual lens reading lamps
- High-flow heater blower
- Engine block heater
- Diesel engine block and fuel line heater
- Body side moldings
- Deluxe luggage compartment trim
- Tires, puncture-sealing
- Tires, P205/75R14 steel-belted radial-ply with raised white letters
- Tires, P195/75R14 steel-belted radial-ply white stripe
- Tires, P205/75R14 steel-belted radial-ply white stripe
- Tires, P185/75R14 glass-belted radial-ply blackwall or white stripe (except Cruisers)
- Tires, P195/75R14 glass-belted radial-ply white stripe (Cruisers)
- Tires, P205/75R14 glass-belted radial-ply with raised white letters (Cruisers)
- California emission equipment and test
- California diesel engine emission requirements
- Cast aluminum wheels
- Super-stock wheels
- Simulated wire wheel discs
- Simulated wire wheel discs with locks
- Floor mats, front and rear

AVAILABLE SPECIAL USE EQUIPMENT

- FE2 suspension package
- High-capacity Delcotron
- Heavy-duty wheels
- Trailer wiring harness
- High-capacity cooling systems

A closer look at what makes Cutlass so popular...

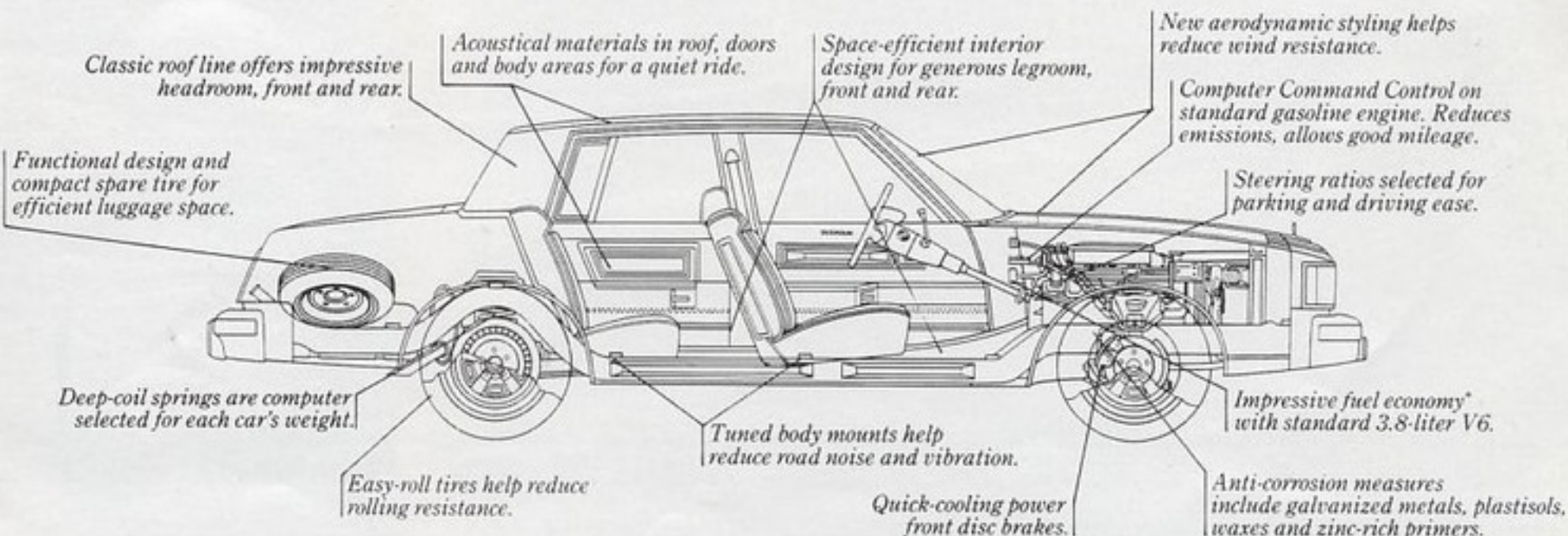

CUTLASS POWER TEAMS*

Standard engine:

Liter/CID/Type 3.8/231/V6

Carburetion 2-bbl.

Available engines:

Liter/CID/Type 4.3/260/V8

Carburetion 2-bbl.

Liter/Type 5.7/Diesel V8

Transmission:

Manual 3-speed, fully sync.

(Standard on Cutlass Sedan.

Automatic available.)

Automatic Column-mounted shifter

(Standard on all other Cutlass models)

Fuel capacity, gasoline (gal.) 18.1

Fuel capacity, diesel (gal.) 19.8

DIMENSIONS . . . (Supreme Coupe/ C Sedan)

Overall length (in.) 200.0/199.1

Wheelbase (in.) 108.1/108.1

Headroom, front (in.) 37.9/38.7

rear (in.) 38.1/37.7

Legroom, front (in.) 42.8/42.8

rear (in.) 36.3/38.0

Luggage capacity (cu. ft.) 16.8/16.3

Shoulder Room, front (in.) 56.6/57.1

rear (in.) 56.1/57.1

Legroom, front (in.) 42.8/42.8

rear (in.) 36.3/38.0

Luggage capacity (cu. ft.) 16.8/16.3

*See EPA mileage estimates in accompanying Engine Supplement Sheet.



OMEGA BROUGHAM
The Oldsmobile of small cars.



OMEGA ES: Now you can have a "European-type" sedan made in the U.S.A.

Omega for 1981. It's the good-lookin', smooth-ridin', high-fashioned, eye-catchin', fuel-sippin', pump-passin', quick-step-pin', road-buggin', comfort-givin', pocket-pleasin', front-wheel drivin' Oldsmobile of small cars.

And it doesn't take an economist to see why. One look and you know Omega is designed, engineered and priced for the times you live and drive in. Its interior offers honest room for five adults— thanks to its transverse-mounted engine

and ingenious engineering.

How's the mileage? An Omega strong point. With the standard 4-cylinder engine or available V6, the mileage is impressive. In fact, EPA estimates indicate you'll be doing a whole lot of pump-passin'.*

As for driving, well... it's smooth-ridin' and road-huggin'. Omega's front-wheel drive puts the engine weight over the wheels that power and steer you. And that means traction. You'll love the way Omega tracks along a snowy street or rain-



OMEGA: Easiest way of all to move into the Oldsmobile of small cars.

slicked highway. You'll like the grip and steadiness in crosswinds. You'll like what rack-and-pinion steering and MacPherson strut suspension do for Omega, too. You'll cruise smoothly, slip in and out of traffic with agility and move into parking

spaces with the greatest of ease. Pure pleasure.

You'll like the new Omega so much you'll want it to last and last. So do we. That's why every Omega receives extensive anti-corrosion treatments. Galvanized metals,

special zinc-rich primers, seals and waxes — all help keep Omega solid and looking good.

If you're looking for a small car, take a good look at the Oldsmobile of small cars. With five great new versions, one is built for you.

Omega Brougham. *The most luxurious version of the car that rewrote the record book for Olds compact car sales. Impressively elegant. Seats are upholstered in a rich, soft velour. Front center armrest, deluxe steering wheel, full wheel*

*See EPA mileage estimates in accompanying Engine Supplement Sheet.



SPORTΩMEGA: You gotta drive it. You're gonna love it: The sportiest Omega of them all.

covers and more—standard. **New Omega ES-2500.** If you'd like a distinctive sedan with European-type flair, we've got your number. It's the available Omega ES-2500 package! And it's got it all. A continental look, with a new, resilient

front end. Blacked-out moldings. Wide side body moldings. Sport-styled mirrors. Sport steering wheel. Power steering and front disc brakes. P205/70R13 steel-belted radial blackwalls. Color-coordinated wheel discs (available sport wheels

shown). Gages. And more. All included in this beautiful silver metallic sedan.

An ES-2800 package, including a 2.8-liter V6 is also available.

Omega. It isn't just another small car. It's an Oldsmobile—with the

kind of room, comfort and value you need in a small car, but didn't think you'd find. Well, you have. And it's affordable. In fact, compare Omega to some less roomy imports and you're in for a pleasant surprise. **New SportOmega.** It's the resilient-



OMEGA SX: Ready to liven up your life.

nosed, flare-fendered, rallye-wheeled newcomer from Olds! A brand new package available for people who love to drive and don't mind being economical* about it. It's big news—from its sleek new front end, to rear deck spoiler. In

between is a whole lot more of what sporty driving is all about. Sport steering wheel, FE2 suspension, bold side striping, plus flared "flex" fenders. They're great new urethane fenders that can't rust; they resist minor bumps and dings and reduce

weight to help contribute to good fuel economy. So pull on those driving gloves and see your Olds dealer. Because we've had a very sporty coupe built for you. **Omega SX.** Whether you're young or young at heart, the available

Omega SX package is at hand to liven your spirit. It's quick as a smile and very youthful—with sassy paint scheme; bold, blacked-out grille, moldings and bumpers; plus rallye trim wheels. Proof that economy* can be great fun.

*See EPA mileage estimates in accompanying Engine Supplement Sheet.

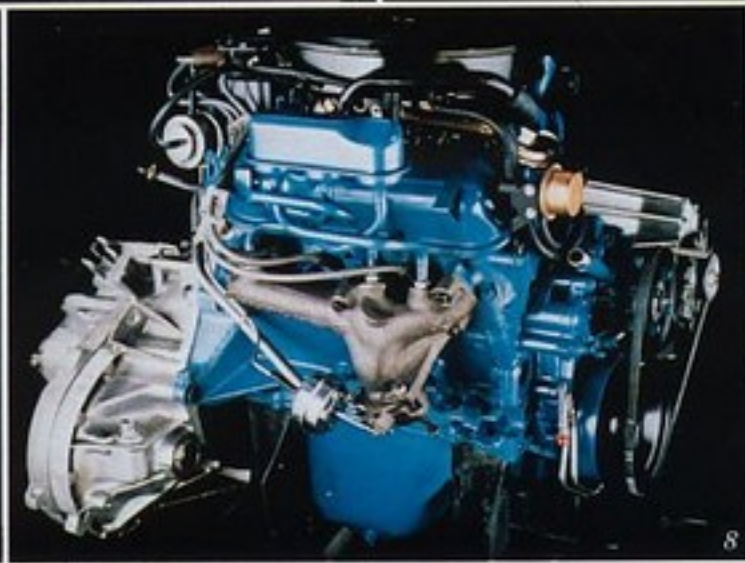

Omega facts, figures, features and options. 1. This handsome instrument panel is standard on Omegas. 2. Available wheel trim: (A.) Polycast styled wheel. (B.) Simulated Wire. (C.) Deluxe with body color. (D.) Rallye. (E.) Deluxe chrome.

(F.) Bright wheel with trim ring. 3. Set your Omega off from others by ordering this stylish paint scheme. 4. Available tinted glass sunroof. 5. New multi-function turn signal lever puts high and low beams, windshield wiper and

washer controls at your fingertips. Also includes Cruise Control and pulse wiper system, if ordered. 6. Zincrometal, zinc sprays, special primers, hot waxes, galvanized metal—all standard—all to help resist corrosion. 7. Lots of luggage,

right? Well, Omega's 14.3-cubic foot trunk can handle it. 8. For still sportier spirit, a 2.8-liter V6 may be ordered. 9. SportOmega instrument panel includes gauges, sport steering wheel and simulated engine turn applique.

**OMEGA STANDARD EQUIPMENT—
ALL MODELS:**

Chassis and body:

■ Computer Command Control ■ Engine, 2.5-liter (151 CID) L4, 2-bbl. ■ Transmission, 4-speed, fully synchronized manual floor shift ■ Low-friction manual steering ■ Integral body-frame construction ■ Front cradle strut engine mounting ■ Transverse-mounted engine with front-wheel drive ■ MacPherson strut front suspension ■ Rack-and-pinion steering ■ High-energy ignition system ■ Space-efficient trunk ■ Compact spare tire ■ Low-drag front disc brakes ■ Bright side window frame moldings ■ Maintenance-free Freedom II battery ■ Delcotron ■ Easy-roll tires, P185/80R13 glass-belted radial-ply blackwall

Interior:

■ Full-foam seat construction with integral head restraints ■ Armrests, front and rear ■ Wall-to-wall cut-pile carpeting ■ Simulated Butterfly Walnut grain instrument panel trim ■ Courtesy lamp, automatic door actuated ■ Cigar lighter ■ AM pushbutton radio with fixed-mast antenna (may be deleted for credit) ■ Inside day-night rearview mirror ■ Seat belts, front and rear ■ Door safety locks integral with door handles

OTHER STANDARD EQUIPMENT BY MODEL:

Omega:

■ Bench seats, choice of cloth or vinyl ■ Bright hubcaps ■ Rocker panel and wheel-opening moldings (Sedan)

Omega Brougham:

■ Custom sport bench with fold-down armrest, cloth ■ Wheel discs ■ Carpeted lower door panels ■ Hood center molding ■ Stand-up hood ornament ■ Lock pillar applique molding (Sedan) ■ Deluxe steering wheel ■ Wide lower and wheel-opening moldings

**OMEGA/OMEGA BROUGHAM
AVAILABLE EQUIPMENT:**

- 6-way power seat adjuster (bucket seat, driver side)
- Removable tempered glass sunroof panel, reduces headroom slightly
- Power door locks
- Deluxe seat belts
- Reclining seat back, passenger side
- Soft-Ray tinted glass
- Power side windows
- 6-way power seat adjuster, bench seat
- Contour bucket front seats
- Sport console (bucket seats required)
- Reclining seat back, driver side
- Power trunk lid release
- Lower body side moldings
- Hood center and front end panel molding (Omega)
- Auxiliary floor mats, front and rear
- Bright roof drip moldings—included with vinyl roof covering
- Body side molding
- Bright door-edge guard moldings
- Pulse wiper system
- Padded vinyl landau rooftop covering (Coupes only)
- Full vinyl rooftop covering (Sedans only)
- Electric rear window defogger
- Four-Season air conditioner
- Combination dome and dual lens reading lamp
- Remote control outside rearview mirror—driver side
- Sport-styled outside rearview mirrors—driver side remote, passenger manual
- Sport-styled outside rearview mirrors—driver and passenger side remote control
- Accent stripe, body side
- Power brakes with front discs
- Engine block heater
- Cruise Control with resume feature
- Custom sport steering wheel

- Luggage roof rack (except with landau or sunroof)
- Tilt-Away steering wheel
- Power steering
- Simulated wire wheel discs
- Simulated wire wheel discs with locks
- Deluxe wheel discs (Omega only)
- Deluxe wheel discs, painted body color
- Styled polycast wheels
- Bright wheel trim rings (Included with SX package) (Omega only)
- Tungsten halogen high beam headlamps
- High-capacity Freedom II battery
- Trip odometer
- Electric clocks, digital and regular
- Radio and tape players (see page 26)
- Automatic power front fender antenna
- Dual horns
- Instrument panel gage clusters
- Bumper rub strips and bumper guards with inserts
- Convenience group package
- Special duo-tone paint scheme
- Tires, P185/80R13 steel- or glass-belted radial-ply white-stripe
- Tires, P185/80R13 steel-belted radial-ply blackwall
- Tires, P205/70R13 steel-belted radial-ply blackwall with raised white letters.

SPECIAL AVAILABLE PACKAGES:

- Omega ES Package**
ES-2500 with 2.5-liter L4 engine or ES-2800 with 2.8-liter V6 engine. Includes soft front end with integral scoop, and bumpers in car color. Bright roof drip moldings. Wide body side moldings that blend with bumper rub strips. Blacked-out headlamp bezels, taillamp bezels, window reveal and pillar applique moldings. P205/70R13 steel-belted radial-ply blackwall tires. Sport-styled outside mirrors. FE2 suspension package. Power front disc brakes.

Custom sport steering wheel. Power steering. Deluxe wheel discs painted body color. Instrument panel gages. Special swirled metal instrument panel trim. (Available only on Omega Brougham Sedan in Silver Metallic with interior trims of Dark Blue or Maple Red.)

SportOmega Package

Includes specific grill. "Soft," sleek front end. Wraparound bumpers with integral scoop in car color. "Flex" fenders that resist minor dings and dents; can't rust. Blacked-out headlamp and taillamp bezels, window reveal and pillar applique moldings. Instrument panel with simulated engine turn applique. Bright roof drip moldings. Sport-styled outside mirrors. FE2 suspension. Power front disc brakes. Custom sport steering wheel. Power steering. Deluxe wheel discs with body paint color. P205/70R13 steel-belted radial-ply blackwalls. Instrument panel gage cluster. (Available only on Omega coupe in white with orange and red body side stripes and bold SportOmega identification above a charcoal painted lower body.)

Omega SX Package

Includes low-gloss black paint on lower body, windshield moldings, side window frames, back window moldings, headlamp and taillamp bezels, rear quarter side marker bezel, grille bars. Front and rear bumpers with bumper rub strip. Rallye trim wheels. Monochromatic side and rear decal stripes with "SX" identification. Sport-styled outside mirrors. (Available only on Omega Coupe.)

AVAILABLE SPECIAL USE EQUIPMENT:

- Firm ride and handling suspension package
- Superlift rear manual adjustable shock absorbers
- High-capacity Delcotron
- High-capacity cooling system.

A closer look at what makes Omega the Oldsmobile of small cars...

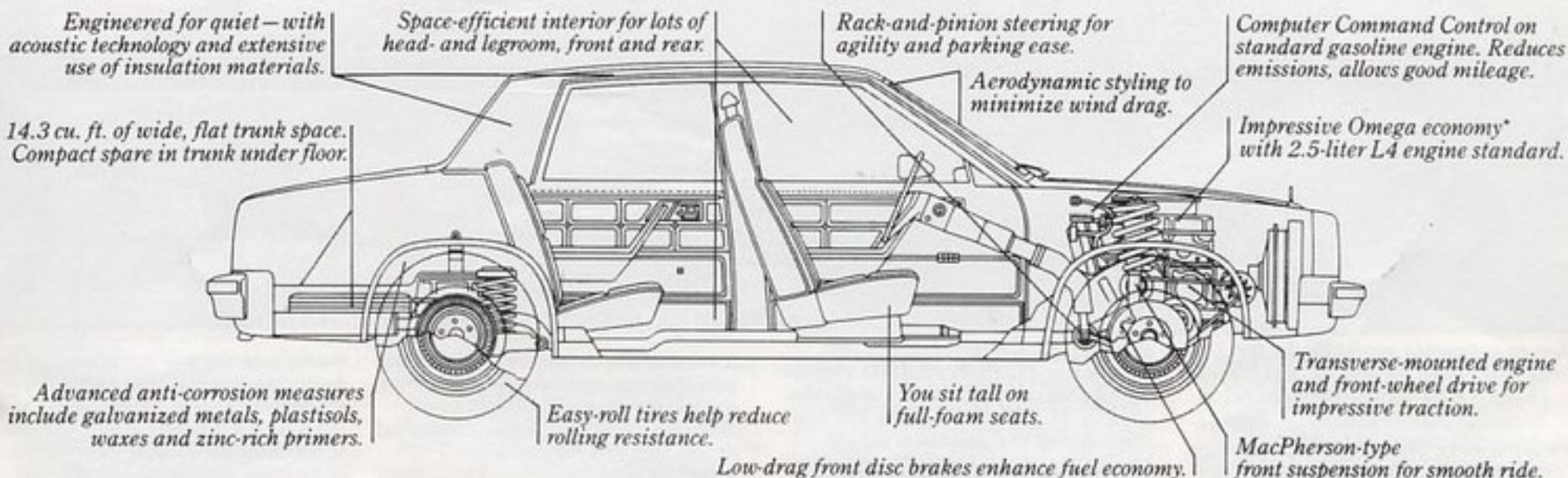

OMEGA POWER TEAMS*

Standard engine:	Carburetion 2-bbl.
Liter/CID/Type 2.5/151/L4	Standard transmission:
Carburetion 2-bbl.	Manual 4-speed floor shift
Available engine:	Available transmission:
Liter/CID/Type 2.8/173/V6	Automatic Column-mounted shifter

DIMENSIONS (Omega Coupe/Sedan)

Overall length (in.) 181.8/181.8	Headroom, front (in.) 38.2/38.2
Wheelbase (in.) 104.9/104.9	rear (in.) 37.4/37.4
Luggage Capacity (cu. ft.) 14.3/14.3	Hiproom, front (in.) 54.5/54.5
Fuel Tank Capacity, gasoline (gal.) 14.0/14.0	rear (in.) 53.5/55.4
	Shoulder Room, front (in.) 56.3/56.0

Legroom 56.3/56.1

front (in.) 42.2/42.2
rear (in.) 34.5/35.5

*See EPA mileage estimates in accompanying Engine Supplement Sheet.

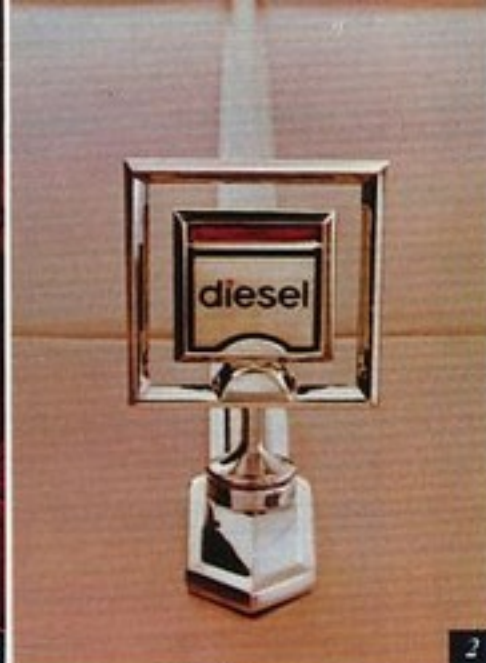

DELCO-GM PREMIUM RADIOS	CUTLASS	OMEGA
AM Pushbutton	A	S*
AM-FM Electronically Tuned Stereo Pushbutton, Tape Player, Digital Station/Clock Display	A	NA
AM-FM Stereo Pushbutton with Tape Player	A	A
AM-FM Stereo Pushbutton with Cassette	A	A
AM-FM Stereo Pushbutton with 40-Channel CB	A	A
AM-FM Stereo Pushbutton	A	A
AM-FM Monaural Pushbutton	A	A

S - Standard A - Available NA - Not Available



Personal touches available for the Olds that's built for you. 1. Tilt-Wheel. 2. Diesel V8 for impressive mileage.* 3. Reclining front seat backs. 4. New electronically tuned AM-FM stereo radio with cassette, Cutlass. 5. AM-FM stereo radio with cassette, Omega. 6. Cruise Control with resume-speed feature. 7. Sport console. 8. Halogen high-beam headlamps. 9. Lighted visor mirror. 10. Fiber-optic lamp monitors. 11. Pulse wipers let you set a variety of delay-interval wipers. 12. Rear window

defogger. 13. Digital clock. 14. Air conditioner. 15. Tri-band power antenna. 16. Electric sunroof, reduces headroom slightly. 17. Takes care of you and your Olds during and after new vehicle limited warranty. Available in U.S. and Canada only. 18. Six-way power seat adjuster. 19. Dual sport mirrors. Additional options listed on pages 17, 25.

NOTE: Availability of optional equipment varies by model. Check your Oldsmobile dealer for details.

A word about assembly, components and optional equipment in these Oldsmobile products: The Oldsmobiles described in this catalog are assembled at facilities of General Motors Corporation operated by Oldsmobile Division and General Motors Assembly Division. These vehicles incorporate thousands of different components produced by various divisions of General Motors and by various suppliers to General Motors. From time to time during the

manufacturing process, it may be necessary, in order to meet public demand for particular vehicles or equipment, or to meet federally mandated emissions, safety and fuel economy requirements, or for other reasons, to produce Oldsmobile products with different components or differently sourced components than initially scheduled. All such components have been approved for use in Oldsmobile products and will provide the quality performance associated



8



9



10



11



12



13



14



15



16

**Continuous
Protection
Plan**

17



18



19

with the Oldsmobile name.

With respect to extra cost optional equipment, make certain you specify the type of equipment you desire on your vehicle when ordering it from your dealer. Some options may be unavailable when your car is built. Your dealer receives advice regarding current availability of options. You may ask the dealer for this information. GM also requests the dealer to advise you if an option you ordered is unavailable.

We suggest that you verify that your car included the optional equipment you ordered or if there are changes, that they are acceptable to you.

Standard accident-avoidance features: Side marker lights and deflectors □ Parking lamps that illuminate with headlamps □ Four-way hazard warning flasher □ Backup lights □ Lane change feature in direction signal control □ Windshield defroster, washer and dual speed wipers □ Vinyl-edged

inside mirror □ Outside rearview mirror □ Dual master cylinder brake system with warning light □ Starter safety switch □ Dual action safety hood latches.

Standard built-in anti-theft features: Anti-theft ignition key reminder buzzer □ Anti-theft steering column lock. **Standard occupant-protection features:** Manual lap belts with push-button buckles for rear and center front (when applicable) passenger positions

□ Manual lap/shoulder belts for driver (with reminder light and buzzer) and right front passenger □ Energy-absorbing steering column □ Passenger guard door locks □ Safety door latches and stamped steel hinges □ Folding seat back latches □ Energy-absorbing padded instrument panel and front seat back tops □ Laminated windshield/tempered side and rear glass □ Safety armrests □ Identification symbols for controls and displays.

There's an Olds that's built for you. Just pick one.

CUTLASS			
 <i>CUTLASS SUPREME BROUGHAM COUPE</i>	 <i>CUTLASS SUPREME COUPE</i>	 <i>CUTLASS CALAIS COUPE</i>	 <i>CUTLASS BROUGHAM SEDAN</i>
 <i>CUTLASS LS SEDAN</i>		 <i>CUTLASS SEDAN</i>	
CUTLASS CRUISER			
 <i>CUTLASS CRUISER BROUGHAM (1)</i>		 <i>CUTLASS CRUISER</i>	
OMEGA			
 <i>OMEGA BROUGHAM COUPE</i>	 <i>OMEGA BROUGHAM SEDAN (2)</i>	 <i>OMEGA COUPE (3)</i>	 <i>OMEGA SEDAN</i>
TORONADO		NINETY-EIGHT	
 <i>TORONADO BROUGHAM COUPE (4)</i>	 <i>98 REGENCY COUPE</i>	 <i>98 REGENCY SEDAN</i>	 <i>98 LUXURY SEDAN</i>
DELTA 88			
 <i>DELTA 88 ROYALE BROUGHAM COUPE</i>	 <i>DELTA 88 ROYALE BROUGHAM SEDAN</i>	 <i>DELTA 88 ROYALE COUPE</i>	 <i>DELTA 88 ROYALE SEDAN</i>
 <i>DELTA 88 COUPE (5)</i>	 <i>DELTA 88 SEDAN</i>	CUSTOM CRUISER	
		 <i>CUSTOM CRUISER (1)</i>	(1) WITH AVAILABLE WOOD-GRAIN VINYL (2) ES PACKAGE AVAILABLE (3) SPORTOMEGA OR SX PACKAGE AVAILABLE (4) XSC PACKAGE AVAILABLE (5) 88 HOLIDAY PACKAGE AVAILABLE

Printed colors are approximates only, and may vary from actual car paint colors. Printed in U.S.A. 8-80

1981 OLDSMOBILE EXTERIOR COLORS ON ALL MODELS



ALL MODELS EXCEPT OMEGA AND TORONADO

PASTEL SAUTERNE

ALL MODELS EXCEPT TORONADO

SAUTERNE GOLD METALLIC

OMEGA MODELS ONLY

DARK GREEN METALLIC, BRIGHT YELLOW, ORANGE METALLIC, BRIGHT RED

TORONADO ONLY

PASTEL BEIGE, DUSKIN METALLIC

TORONADO AND NINETY-EIGHT ONLY

DARK JADESTONE FIREMIST, SILVER FAWN FIREMIST, SLATE GRAY FIREMIST

