

1975 CHEVROLETS



**CHEVROLET
MAKES SENSE FOR AMERICA
IN EVERY WAY.**

Americans come in all sizes and shapes. They vary widely in their personal, working and recreational needs. So when it comes to choosing cars, their desires range across a broad spectrum of sizes, styles, colors, performance characteristics and equipment. All of those are reasons why Chevrolet offers America such a great variety of models to choose from.

22 SMALL CARS.

Monza 2 + 2—
3 Vegas—
16 Novas—
2 Camaros



13 MID-SIZE CARS.

11 Chevelles—
2 Monte Carlos



9 FULL-SIZE CARS.

4 Caprice Classics—
4 Impalas—
Bel Air Sedan



14 STATION WAGONS.

6 full-size wagons—
6 mid-size wagons—
2 small-size wagons



2 SPORTS CARS.

2 Corvettes



4 SPECIALTY VEHICLES.

Fleetside Pickup—
Blazer—
Sportvan—
Suburban





Monza 2+2 Hatchback Coupe. See your Chevy dealer for a detailed 1975 Monza 2+2 catalog.

MONZA 2+2. OUR NEW SMALL CAR.



Monza 2+2 interior

The small car of tomorrow will be a little more of everything. It'll probably be more advanced and economical, probably a little more powerful, fun to drive, handier to load with packages, a little more comfortable to be in.

The 1975 Monza 2 + 2 approaches this today, right down to the neat new rectangular headlights.

Power ventilation keeps a blower working on low speed all the while the ignition's on. The circulated air exhausts

through stylish side louvers.

Underhood: the standard 2.3-litre 4-cylinder engine or available 4.3-litre V8. The hatchback rear door opens up the entire back of the car for wagon-type loading. Standard features include special instrumentation, resilient urethane front end, 4-Speed manual transmission and GM-Specification radial ply tires.

Monza 2 + 2 is the beginning of tomorrow.



Monza 2+2 with hatchback open



Vega Hatchback with available GT equipment. See your Chevy dealer for a detailed 1975 Vega catalog.

VEGA. OUR BEST-SELLING SMALL CAR.



Custom cloth interior

Vega is an economy car and a half. Comfortable, fun to drive and designed to be economical to buy and operate. The catalytic converter, High Energy Ignition and outside air induction of Chevrolet's new Efficiency System are standard; also, more equipment is available than in previous years.

One of the lowest priced cars made, Vega boasts a peppy little overhead-cam 4-cylinder engine that squeezes a lot of

miles out of every gallon of unleaded gas.

But Vega's more than just an economy car. With Vega, you also get sportiness, range, variety and versatility. Bucket seats and floor carpeting are standard in a long list of little niceties you might not expect in economy cars.

No wonder Vega's proved so popular. The '75 Vegas intend to keep it that way.



LX Notchback



Notchback



LN Coupe. See your Chevy dealer for a detailed 1975 Nova catalog.

NOVA. OUR FAMILY-SIZE SMALL CAR.

Nova began 14 years ago as an economical, solid, comfortable car for the small family. Now come the evolutionary new Novas, all emphatically refined for 1975, plus two new, luxurious LN models.

Nova's inner goodness comes to the surface in 16 models (Six and V8), with refined styling inside and out, improved air distribution system, increased glass area and lots more that makes sense.

Nova's always been good. Now it's beautiful.



LN 4-Door Sedan



Custom 4-Door Sedan



Nova Coupe



Custom Hatchback Coupe



Nova Hatchback Coupe



Nova 4-Door Sedan



Custom Coupe



Nova SS Coupe

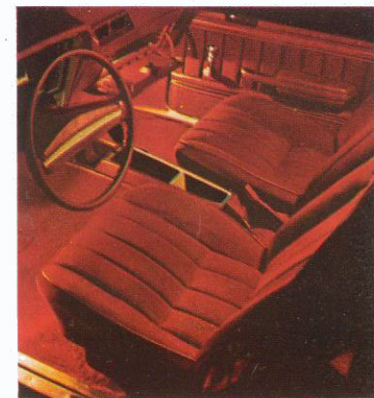

LN Coupe interior



Type LT Coupe. See your Chevy dealer for a detailed 1975 Camaro catalog.

CAMARO. OUR SENSIBLY SPORTY SMALL CAR.



Type LT cloth-and-vinyl interior

You may be driving more slowly now, and perhaps less. But there's nothing that says you can't drive with a smile on your face. These ninth editions of our sporty Camaro—Sport Coupe and Type LT Coupe—are designed to help keep you driving happy. Each is stylish, but sensible.

You don't have to load up a Camaro to enjoy it. With newly refined Six or V8, you also get GM-Specification steel-belted radial ply tires, front disc brakes, new finned

rear brake drums, High Energy Ignition, catalytic converter, 21-gallon gas tank and other pleasant surprises, all standard equipment.

On the other hand, you do have ways to make your Camaro individual. Features available include air conditioning, Interior Decor/Quiet Sound Group (standard on Type LT) and dozens more comfort, dress-up and convenience items.

And the way it looks is the way it goes.



Camaro Sport Coupe.

13 MID-SIZE CHEVROLETS



Two views of Malibu Classic Sedan. See your Chevy dealer for a detailed 1975 Chevelle catalog.

CHEVELLE. OUR PRACTICAL MID-SIZE CAR.

For '75, Chevelle presents a combination of good things—mid-size, mid-price, efficiency, comfort and ample room for six adults. What's more, Chevelle offers you Chevrolet's solid reputation for value.

We want your 1975 Chevelle to be the most satisfying new car you ever brought home. So a wide choice is yours, from thriftiest Malibu up through distinctive Malibu Classic and sporty Laguna Type S-3.



Malibu Classic Landau Coupe



Malibu Coupe



Malibu Classic Coupe



Malibu Sedan



Laguna Type S-3 Coupe. Check your Chevy dealer for availability.



Interior of Malibu Classic Coupe



Monte Carlo Landau Coupe. See your Chevy dealer for a detailed 1975 Monte Carlo catalog.

MONTE CARLO. OUR DISTINCTIVE PERSONAL-SIZE CAR.



Custom interior

When a car makes you feel good about its looks, that's styling. When it makes you feel good about yourself, that's character. And that's what this beautiful-riding, beautiful-handling Monte Carlo, 1975, is all about—honest, tasteful, with classic design and elegance.

Monte Carlo's exterior has now met its match with the distinctive new 1975 Custom interior that's available. With it, you specify your choice of 50/50 reclining passenger seat or swivel bucket seats. The

standard interior takes a comfortable approach to driving with molded full foam bench seat, deep nylon cut-pile carpeting and color-keyed instrument panel, steering wheel and steering column. There's everything you'd expect in a car so tasteful.

To make ownership even more attractive, Monte Carlo also features Chevrolet's new Efficiency System.

A car this impressive wouldn't have to be sensible. But it is.



Monte Carlo Coupe



Caprice Classic Sport Sedan. See your Chevy dealer for a detailed 1975 Chevrolet catalog covering Caprice Classic.

CHEVROLET CAPRICE CLASSIC. OUR UPPERMOST CAR.



Caprice Classic Sport Sedan cloth-and-vinyl interior

If the four distinctive 1975 Caprice Classic models strike you as having a lot more than is absolutely necessary in a full-size automobile, good, we intended it that way.

For '75, the Caprice Classic Coupe retains the flair of a dramatic hardtop roof set off by Caprice's new styling. The 4-door sedan combines pillared roof design with more window area in rear doors. The sport sedan shows a new roof style, too. And the convertible for the first time offers

an available 50/50 reclining passenger seat and a sport cloth interior.

Every '75 Caprice includes Chevrolet's new Efficiency System designed to translate into improved fuel economy and reduced maintenance and service intervals.

Of course, the standard equipment list runs long on these uppermost Chevrolets, from added insulation of Chevrolet's Quiet Sound Group to power steering, power brakes and Turbo Hydra-matic.



Caprice Classic 4-Door Sedan



Caprice Classic Coupe



Caprice Classic Convertible



Impala 4-Door Sedan. See your Chevy dealer for a detailed 1975 Chevrolet catalog covering Impala.

CHEVROLET IMPALA. AMERICA'S FAVORITE CAR.

Impala, traditionally the most popular car in America's history, again presents four outstanding full-size models, including two coupes and two 4-door sedans.

The '75 Impala Custom Coupe achieves stand-out prominence with sophisticated roof design and large side quarter windows. Both the Impala Sport Sedan and Impala 4-Door Sedan feature a new roof design with larger rear side windows. And for the first time, the 50/50 reclining passenger

seat is available in Impala models.

Impala also now includes new economy features like Early Fuel Evaporation and other Efficiency System components. More than ever, Impala is The Great American Value.



Impala Sport Sedan



Impala Sport Coupe



Impala Custom Coupe



Bel Air 4-Door Sedan

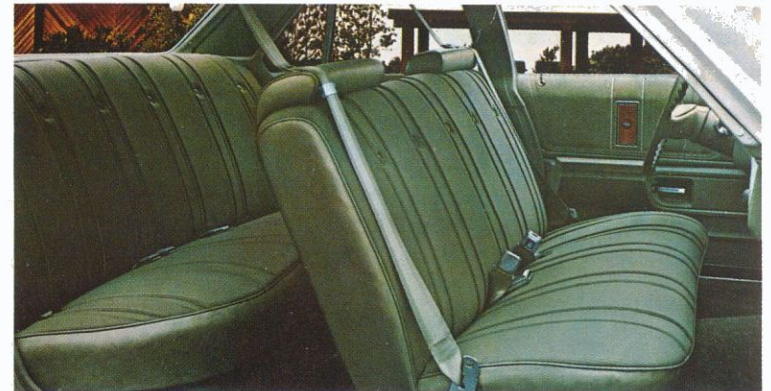

Impala cloth-and-vinyl interior



Caprice Estate. See your Chevy dealer for a detailed 1975 Wagon catalog.

CHEVROLET. OUR SPACIOUS FULL-SIZE WAGON.

America's family station wagon builder offers six full-size wagons in 2- and 3-seat models with practical features for practically every family.

All are equipped with Glide-Away tailgate to let you load and unload in cramped quarters. And all rear seats are the handy Flip-Down type. Other standard features: GM-Specification steel-belted radial ply tires, power steering, power front brakes, Turbo Hydra-matic, 400-4 V8 with High Energy Ignition system.

A notable list of available equipment lets you tailor these versatile full-size wagons to your desire. You may order anything from Comfortron air conditioning to trailering equipment.

Caprice Estate, our uppermost wagon, offers our finest blend of wagon practicality, comfort and tasteful styling. Impala is our Great American Value in wagons. And Bel Air presents the full-size Chevrolet basics at an economy price.



Impala Wagon



Bel Air Wagon

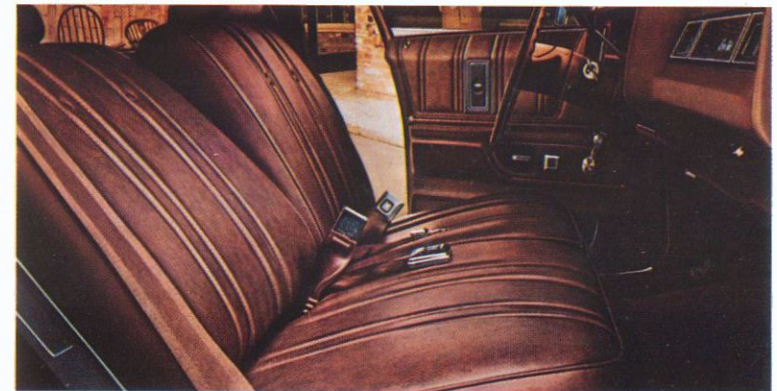

Caprice Estate all-vinyl interior with available 50/50 front seat



Malibu Classic Estate



Vega Wagon with available GT equipment



Vega Estate Wagon

CHEVELLE. OUR VERSATILE MID-SIZE WAGON.



Malibu Classic Wagon



Malibu Wagon

Thoughtful spenders seeking a mid-size family wagon need look no further than Chevelle. The choice is wide, from among six 2- and 3-seat models with swing-open tailgate, V8 engine, power steering and brakes, GM-Specification steel-belted radial ply tires and much more that's standard.

Your search for an efficient, dependable wagon can start and end with Chevrolet's popular mid-size Chevelle.

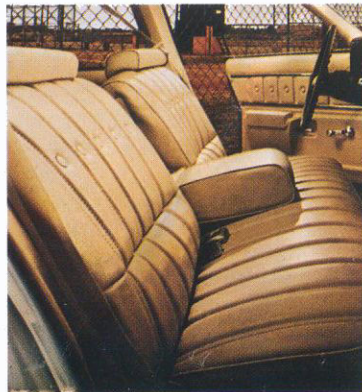

Malibu Classic Estate all-vinyl interior

VEGA. OUR NEAT SMALL-SIZE WAGON.



Vega Wagon

Our sensible small-size Vega wagons offer more than economy. Standard, for example, are a perky 4-cylinder engine, 3-Speed manual transmission, new larger front suspension lower ball joints, power ventilation—the list goes on.

One of our handy Vegas is likely just the ticket for those who elect to travel in sporty, compact wagon style.



Corvette-Coupe and Convertible. See your Chevy dealer for a detailed 1975 Corvette catalog.

CORVETTE. AMERICA'S ONLY TRUE PRODUCTION SPORTS CAR.

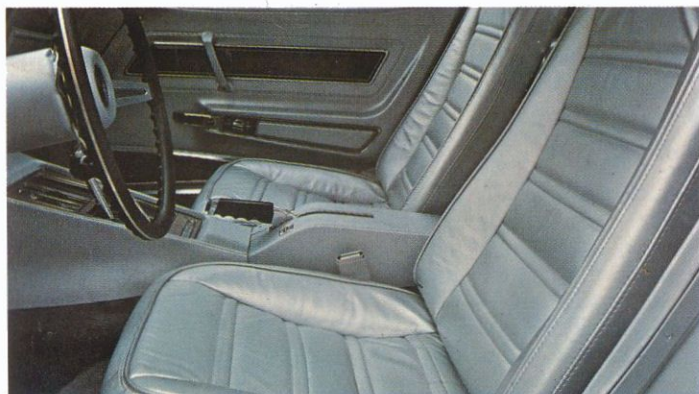

Available Custom interior with leather seat panels.

Readers of *Car and Driver* magazine last year chose Corvette as "Best All-Around Car." Now meet this year's version—with added refinements!

The coupe offers convenient remove-and-store panels; the convertible features a fast-folding top that hides away. Standard interior is durable all-vinyl. A Custom leather trim interior is available.

Refinements in Corvette's aerodynamic styling for '75 include new front and

rear bumper guards.

One of the chief contributors to Corvette's handling and cornering is full 4-wheel independent suspension.

The standard power team is a 350-4 V8 with wide-ratio 4-Speed manual transmission. Equipment available includes Special 350 4-barrel V8, Turbo Hydra-matic, 4-Speed close-ratio manual transmission, Tilt-Telescopic steering wheel and AM/FM/Stereo radio.

4 SPECIALTY VEHICLES



Cheyenne Fleetside

FLEETSIDE PICKUP.

Slide in a camper and go. Fleetside provides a solid foundation for pickup campers. With rugged 6½- or 8-ft. box,

it handles most camper bodies. Our "Big Dooley" with dual rear wheels is rated 10,000 lbs. GVW.



Beauville Sportvan

SPORTVAN.

On 110" and 125" wheelbases. G20 seats up to 8; G30 seats up to 12. Sportvan holds up to 260 cu. ft. of cargo

with rear seats removed. Power front disc brakes, sliding side door are standard. Available engines go up to a 400-cu.-in. V8.



Cheyenne Blazer

BLAZER.

Blazer can take you where you want to go—with people and gear you want to take along. Comes in

open model or hardtop model with roll-bar plus tailgate and crank-down window. Several interiors available.



Silverado Suburban

SUBURBAN.

Seats 6 as two-seater, 9 as three-seater. There's 143 cu. ft. of cargo room with center seat folded, rear seat out. Can be

equipped to handle up to 14,500 lbs. GCW (combined weight of loaded vehicle, trailer, passengers and equipment).

AND LOTS OF OPTIONS

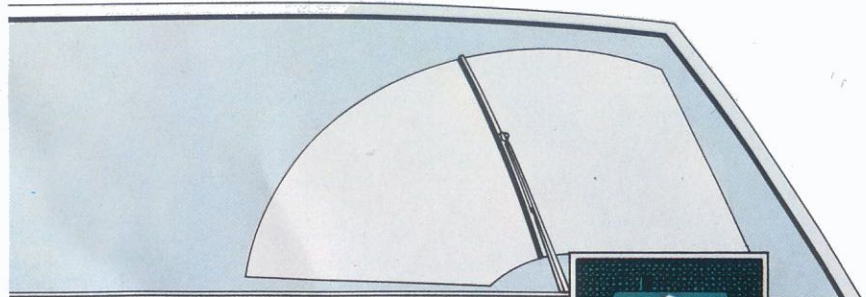

Intermittent windshield wiper system

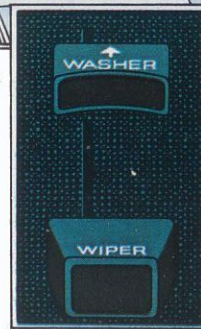

Comfortilt steering wheel

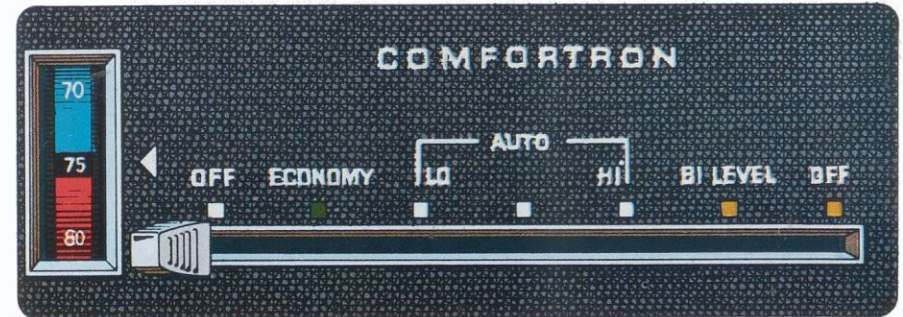

Air conditioning



Speed and cruise control

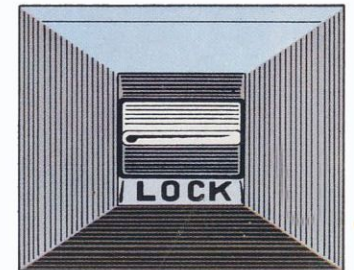

Power door locks



Deluxe bumpers/bumper guards

1975 AVAILABLE OPTIONS. FOR ADDITIONAL COMFORT, CONVENIENCE AND

MONZA 2 + 2

4.3-litre V8 • Turbo Hydra-matic • Power brakes • Power steering • Air conditioning • Space-Saver spare tire • Forged aluminum wheels • Comfortilt steering wheel • Rear window defogger • AM/FM/Stereo radio.

VEGA

140-2 4-cyl. engine • Turbo Hydra-matic • 4-Speed manual transmission • Power brakes • Power steering • Air conditioning • Custom Exterior

• Special Custom Interior • Sport suspension (included with GT) • Comfortilt steering wheel • GT Package • AM/FM/Stereo radio • GM-Specification steel-belted radial ply tires.

NOVA

350-4 V8 • Turbo Hydra-matic • 4-Speed manual transmission • Intermittent wipers • Strato-bucket seats • Power brakes • Power steering • Power door locks • Air conditioning • Rear window defogger • AM/FM/Stereo radio • Auxiliary lighting

• Vinyl roof • Exterior Decor Package • Console.

CAMARO

350-4 V8 • Turbo Hydra-matic • 4-Speed manual transmission • Radial-tuned suspension • Turbine I wheels • Full wheel covers • Rally wheels • Console • Air conditioning • AM/FM/Stereo radio.

CHEVELLE

454-4 V8 • Turbo Hydra-matic • Power Sky Roof (coupes) • Econominder Gauge Package • Radial-tuned suspension

• Intermittent wipers • Strato-bucket swivel seats • Electric trunk opener • Wire wheel covers • AM/FM/Stereo radio.

MONTE CARLO

454-4 V8 • Turbo Hydra-matic • 50/50 reclining passenger seat • Custom Interior • Econominder Gauge Package • Power Sky Roof • Power trunk opener • Air conditioning • Power door locks • AM/FM/Stereo radio.

CAPRICE CLASSIC, IMPALA
454-4 V8 • 50/50 reclining pas-

senger seat • Intermittent wipers • Air conditioning • Deluxe bumpers • Bumper guards • Power door locks • Power trunk opener • Quiet Sound Group (std. on Caprice) • Deluxe trunk trim (except convertible) • AM/FM/Stereo radio with stereo tape system.

CHEVROLET WAGONS

454-4 V8 • 50/50 reclining passenger seat • Econominder Gauge Package • Load-floor carpet • Power tailgate • Tailgate window defogger • Roof carrier

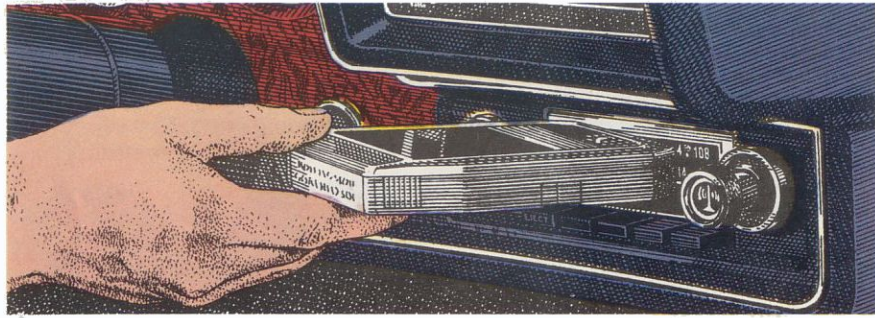

AM/FM/Stereo radio with stereo tape system

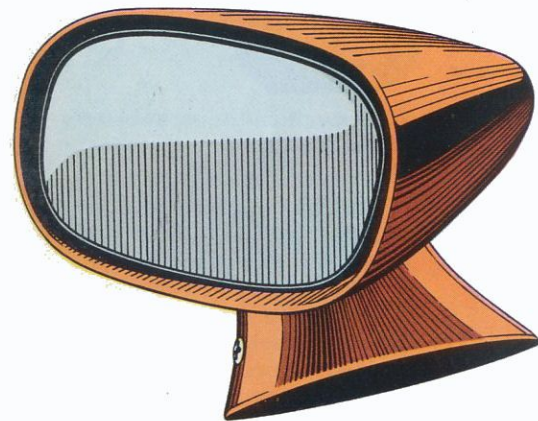

Sport mirrors

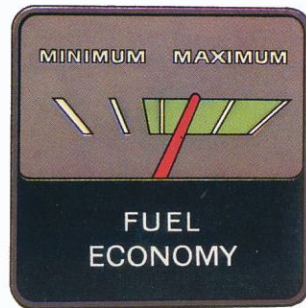

Econominder Gauge Package



Swivel Strato-bucket front seats and Power Sky Roof

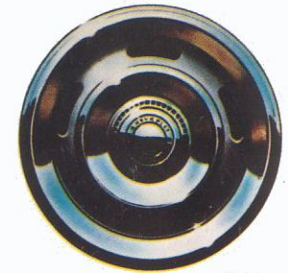

Rally wheels



Full wheel covers

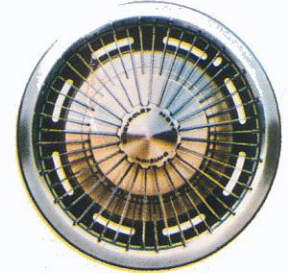

Wire wheel covers

CAR-OWNING SATISFACTION.

• Heavy-duty front and rear suspension • Speed and cruise control • AM/FM/Stereo radio.

CHEVELLE WAGONS
454-4 V8 • Power windows • Econominder Gauge Package • Power tailgate release • Air conditioning • Rear window air deflector • Load-floor carpet • Roof carrier • AM/FM/Stereo radio • Stereo tape system.

VEGA WAGONS
40-2 4-cyl. engine • Turbo Hydra-matic • 4-Speed manual transmission • Roof carrier

• Air conditioning • Power steering • Power brakes • Sport suspension • Comfortilt steering wheel • GT Package • Rear window air deflector • Dual sport mirrors • AM/FM/Stereo radio • Steel-belted radial tires.

CORVETTE
Special 350-4 V8 • Close-ratio 4-Speed manual transmission • Gymkhana suspension • Off-Road Package • Custom leather trim interior • Luggage carrier • Tilt-Telescopic steering wheel • Air conditioning • AM/FM/

Stereo radio.

FLEETSIDE PICKUP
350-4 V8 • 454-4 V8 • 4-Speed manual transmission • Turbo Hydra-matic • Scottsdale, Cheyenne or Silverado trim • Air conditioning • Power steering • Below-Eyeline mirrors • Auxiliary fuel tank • Bucket seats.

BLAZER
4-Speed manual transmission • Turbo Hydra-matic • Cheyenne trim • Custom Deluxe trim • Special instru-

mentation • AM/FM radio • Air conditioning • Power steering • Below-Eyeline mirrors.

SUBURBAN
350 4-barrel V8 • 454-4 V8 • Turbo Hydra-matic • Wagon-type tailgate • Air conditioning • Power steering • Below-Eyeline mirrors • Comfortilt steering wheel.

SPORTVAN
400-4 V8 • 4-Speed manual transmission • Turbo Hydra-matic • Custom Appearance Package • Beauville trim • Air

conditioning • Power steering • Custom Comfort Package • Below-Eyeline mirrors • Comfortilt steering wheel • AM/FM radio.

Availability of these items often depends on model and other equipment selected. Some are dealer-installed accessories only. Your Chevrolet dealer can answer any questions concerning specific items and provide more complete lists of available options for specific models.

CHEVROLET'S NEW EFFICIENCY SYSTEM FOR ECONOMICAL OPERATION.

It's the key part of a program to make our new cars run leaner (more economically), run cleaner (to meet federal emission standards) and save you money every mile.

Here are brief facts on this new Efficiency System:

Newly extended service intervals.

The catalytic converter, High Energy Ignition and use of unleaded fuel combine to contribute valuable savings in maintenance and replacement costs. These are the facts, based on normal driving conditions (check Owner's Manual for full details):

Item	New '75 Schedule	Old '74 Schedule
Engine oil change	Every 6 mos. or 7500 mi.	Every 4 mos. or 6000 mi.
Oil filter change	After 1st 7500 mi., then every 15,000 mi.	After 1st 6000 mi., then every 12,000 mi.
Spark plug change	Every 22,500 mi.	Every 6000 mi.
Chassis lube	Every 6 mos. or 7500 mi.	Every 4 mos. or 6000 mi.
Transmission fluid	Every 30,000 mi.	Every 24,000 mi.

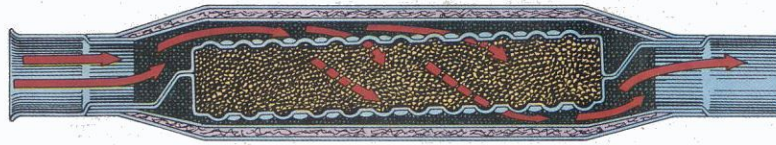

New catalytic converter.

GM's catalytic converter development program included 1,000 vehicles, going over 20 million miles. The converter is the key to burning unleaded fuel more efficiently while contributing to cleaner air.

High Energy Ignition (HEI).

Our HEI system permits more thorough combustion of fuel-air mixtures—even those ordinarily hard to ignite. It does this by supplying up to 85% hotter spark to plugs for quicker,

more positive starting in wet weather, deep cold or desert heat. The larger, hotter spark ignites more of the fuel-air mix. And HEI eliminates breaker points and condenser adjustment that require replacement.

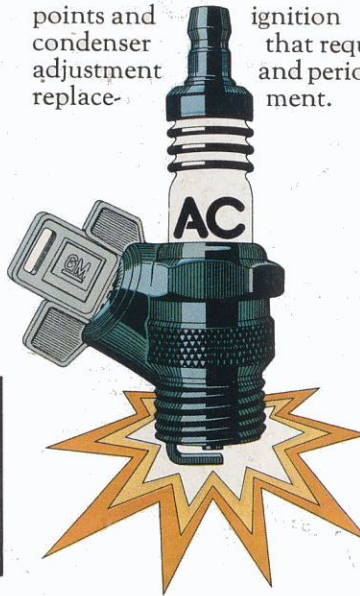

New Early Fuel Evaporation system.*

This system hastens engine warm-up, promotes smooth performance until engine reaches normal operating temperature. Faster warm-up means added fuel savings, especially in cold-weather short runs.

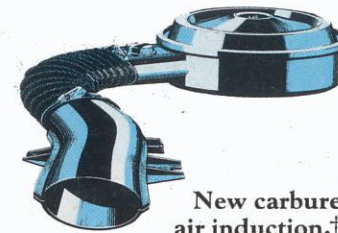

New carburetor air induction.†

Chevrolet's new air induction funnels outside air directly to air cleaner and carburetor. This new induction method is designed to provide the engine with better breathing, especially after engine warm-up.

*Standard on all '75 Chevrolet V8s and most Sixes.

†Standard on all '75 Chevrolet engines except certain Nova Sixes and Monza 2+2 available V8.

New engine fine tuning.

Chevrolet's Efficiency System permits finer tuning to further enhance overall fuel economy.

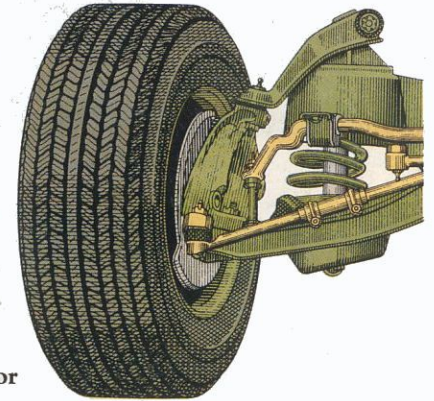

GM-Specification steel-belted radial ply tires.‡

Chevrolet's radial ply tires result from years of research and testing by GM. They're built to GM-specified design requirements. Their lower rolling resistance contributes to improved fuel economy and their advanced tread design provides improved traction on wet and snowy roads.

‡Available on Vegas; standard on other '75 Chevrolet cars.

All illustrations and specifications contained in this literature are based on the latest product information available at the time of publication approval. The right is reserved to make changes at any time without notice, in prices, colors, materials, equipment, specifications and models, and to discontinue models. Chevrolet Motor Division, General Motors Corporation, Detroit, Michigan 48202. Litho in U.S.A.

