

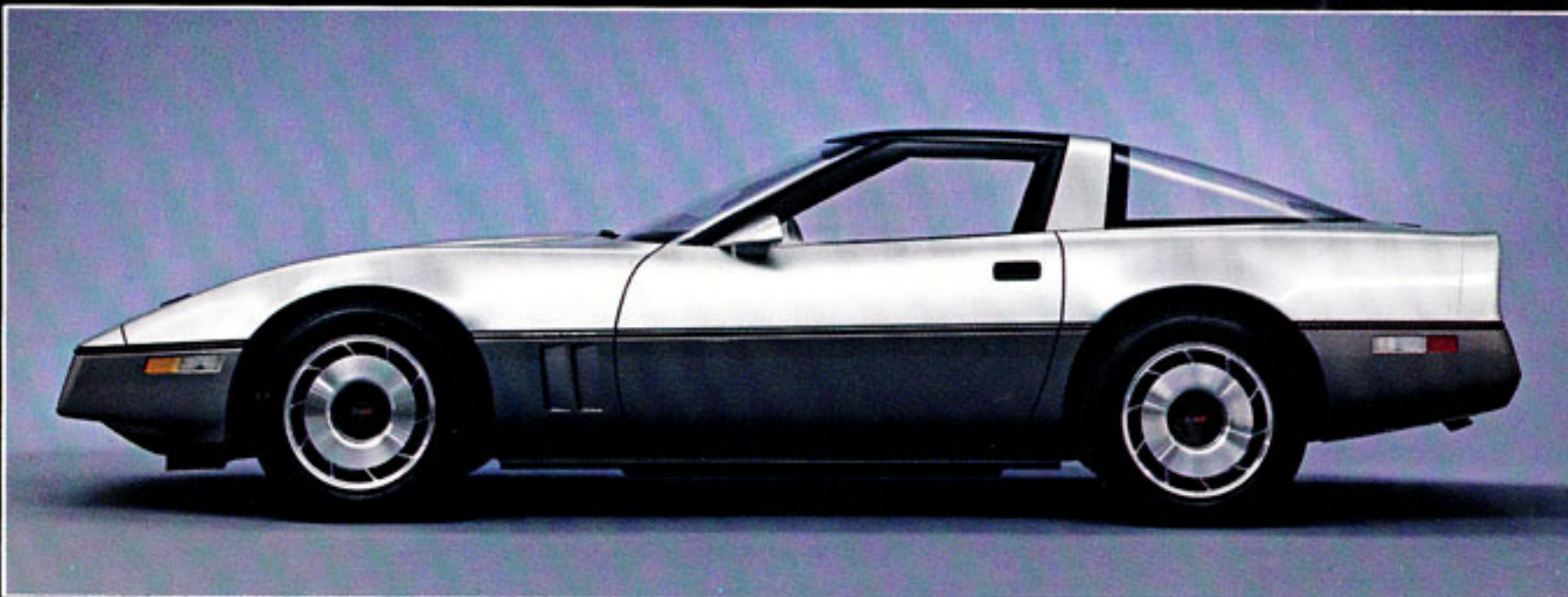

Corvette Hatchback Coupe



Corvette Hatchback Coupe



Corvette Hatchback Coupe

CORVETTE

Capping Over 30 Years of Heritage with a Totally New World-Class Edition

Designed to carry the Corvette colors to new heights of world esteem, this fresh, new model carries some of the most technologically advanced and sophisticated features of any production model ever! Space-age microelectronics with two on-board computers, armed with a 14-K memory and more than 6,600 individual instructions, monitor, control and compute at exact split-second intervals. These units transmit hundreds of thousands of data bits to the driver's command center. There's a whole new set of standards for total performance, precise control, style and built-in finesse. This is the first production model with LCD readout of speed, mileage, RPM and engine functions. And with a flip of the switch, English or metric readouts. Standard is the automatic transmission with overdrive, with computer-controlled torque converter clutch in three top gears. Plus an exclusive 4-speed manual transmission with computer-controlled overdrive in the three top gears, is available.*

*Interim availability

**May be deleted for credit

This is one of the most completely standard-equipped sports cars in the world — with even more standard equipment added to that from years past. Some of the more significant standard features include: Cast alloy road wheels, available in both 15- and 16-inch sizes. Formula I-type front and rear suspension arms with transverse glass-epoxy composite springs. A full-glass rear hatch released from three convenient locations. Side window defoggers, electrically controlled side mirrors, automatic power antenna, halogen fog lamps and rear-corner backup lamps. Plus electronically tuned, seek and scan AM/FM stereo radio with digital clock and four-speaker system.** Special wool-pad comfort liner on seats and a one-piece removable roof panel — all standard. Available in two different ride and handling trims, this new model is the finest example in the continuing quest for excellence that has made Corvette a standout on the streets and the tracks for many years.

Many previous Corvettes are considered classics; this model should continue that heritage.

1984 CORVETTE

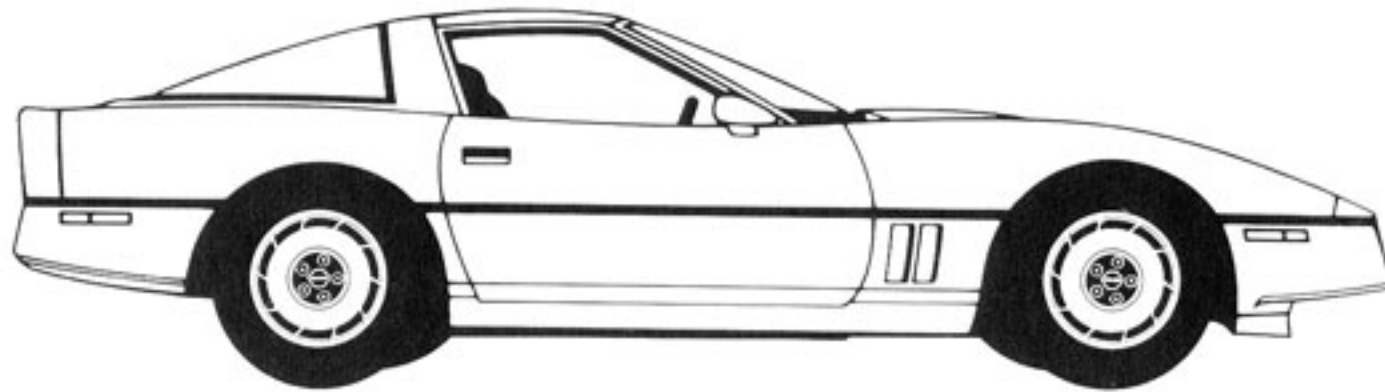

Hatchback Coupe

Corvette

Model No.

Hatchback Coupe 1YY07

Index

Equipment Summary	2
Feature Highlights	3-7
Corvette Coupe	8-9
Interior Features	10-11
Color and Trim	12
Options and Accessories	13
Body Features	14-15
Power Teams	16
Service Intervals	16
Dimensions/Specifications	16

EQUIPMENT SUMMARY

POWER TEAMS/ CHASSIS/MECHANICAL	Corvette Hatchback
Computer Command Control	S
5.7 Liter CFI V8 engine (Cross-Fire Injection)	S
Automatic transmission with overdrive in three top gears	S
Aluminum intake manifold, tuned crossover runners	S
Stainless steel exhaust manifolds and free-flow mufflers	S
Hydraulic valve lifters and exhaust valve rotators	S
Magnesium engine valve covers	S
Magnesium air cleaner housing with dual-snorkel; dual, hood-mounted ducts for outside air pickup	S
Poly-Vee single-belt engine accessory drive belt	S
Electric in-tank twin turbine fuel pump	S
Electric engine coolant fan	S
High Energy Ignition system	S
Freedom Plus II battery with sealed side terminals	S
Power rack-and-pinion steering	S
Power disc brakes at all four wheels with 11.5" rotors and finned aluminum calipers	S
Exclusive monoleaf glass-epoxy composite transverse front and rear springs	S
Forged aluminum front and rear suspension arms	S
Special drive-shaft U-joint splash shields	S
Limited-slip differential	S
Sturdy uniframe body structure 100% galvanized and dip-painted	S
Fully independent four-wheel suspension	S
P215/65R-15 steel-belted radial ply blackwall tires (Goodyear Eagle GT)	S
Cast alloy aluminum wheels, steel compact spare	S

POWER TEAMS/ CHASSIS/MECHANICAL (Cont'd)	Corvette Hatchback
Theft-deterrent system with starter interrupt	S
Side-lift jack	S
EXTERIOR	
Front fender louvers	S
Front cornering lamps; rear corner illuminators	S
Automatic power antenna	S
Power-operated dual quartz-halogen retractable headlamps	S
Dual quartz-halogen fog lamps in grille opening	S
Dual electric remote-controlled sport mirrors	S
Tinted and flush-mounted glass	S
Full-tilting clam-shell-type hood	S
Single removable roof panel with theft-deterrent mount	S
Styled engine compartment	S
Designed-in body side molding	S
Frameless rear hatch glass with three remote releases	S
Body-color front and rear soft fascia with integral front air dam	S
Energy-absorbing bumper systems	S
Corrosion-resistant fiberglass body panels	S
Concealed wipers with integral washers in wiper arms	S
INTERIOR	
Contour-shell cloth bucket seats with manual folding backrest	S
Soft-padded and carpeted door panels	S
Power windows	S
Side window defogger	S

INTERIOR (Cont'd)	Corvette Hatchback
ETR™ AM/FM stereo radio w/seek and scan, digital clock and four speakers*	S
Air conditioning	S
High-intensity interior lamps on door sidewall and "B" pillar	S
Underdash courtesy lamps	S
Twin underhood lamps	S
Headlamp-on reminder	S
Intermittent windshield wipers	S
Illuminated RH visor vanity mirror	S
Leather-wrapped steering wheel rim and horn button	S
Tilt-Telescopic steering wheel	S
Driver information system: includes instant MPG, average MPG, and range in digital readouts	S
Ultracontemporary instrument panel featuring electronic liquid-crystal instrumentation with multi-colored analog and digital display. Readouts include: speedometer, 6,000 RPM tachometer, fuel level, oil pressure, oil temp., voltmeter, and trip odometer. Conventional readouts for odometer, turn signals and high-beam headlamps	S
Manual inside hood release and three electric remote hatch releases	S
Center console with shifter, coin tray, cigarette lighter and ashtray, power window, radio and air conditioning controls	S
Day/night rearview mirror	S
Deep-twist floor and stowage area carpet	S
Rear underfloor storage compartments (2)	S
Acoustical insulation package	S
Luggage compartment concealment roller shade	S

S — Standard *May be deleted for credit

FEATURE HIGHLIGHTS

1. Clamshell hood opening for convenient engine access
2. Twin underhood lamps
3. Retractable, aerodynamic halogen headlamps protected from road splash
4. 350 CID V8 with Cross-Fire Electronic Fuel Injection
5. Thermostatically controlled electric cooling fan

6. Tires: P215/65R-15 Eagle GT blackwalls standard
P255/50VR-16 Eagle VR50 blackwalls available
7. Independent, SLA suspension with transverse fiberglass spring
8. 65° windshield angle
9. One-piece removable roof panel

10. Full-opening glass hatch with concealed hinges
11. Roller-shade-type cargo cover and twin, covered stowage bins
12. Concealed gas filler with cap holder
13. 20-gallon fuel tank with twin-turbine electric fuel pump

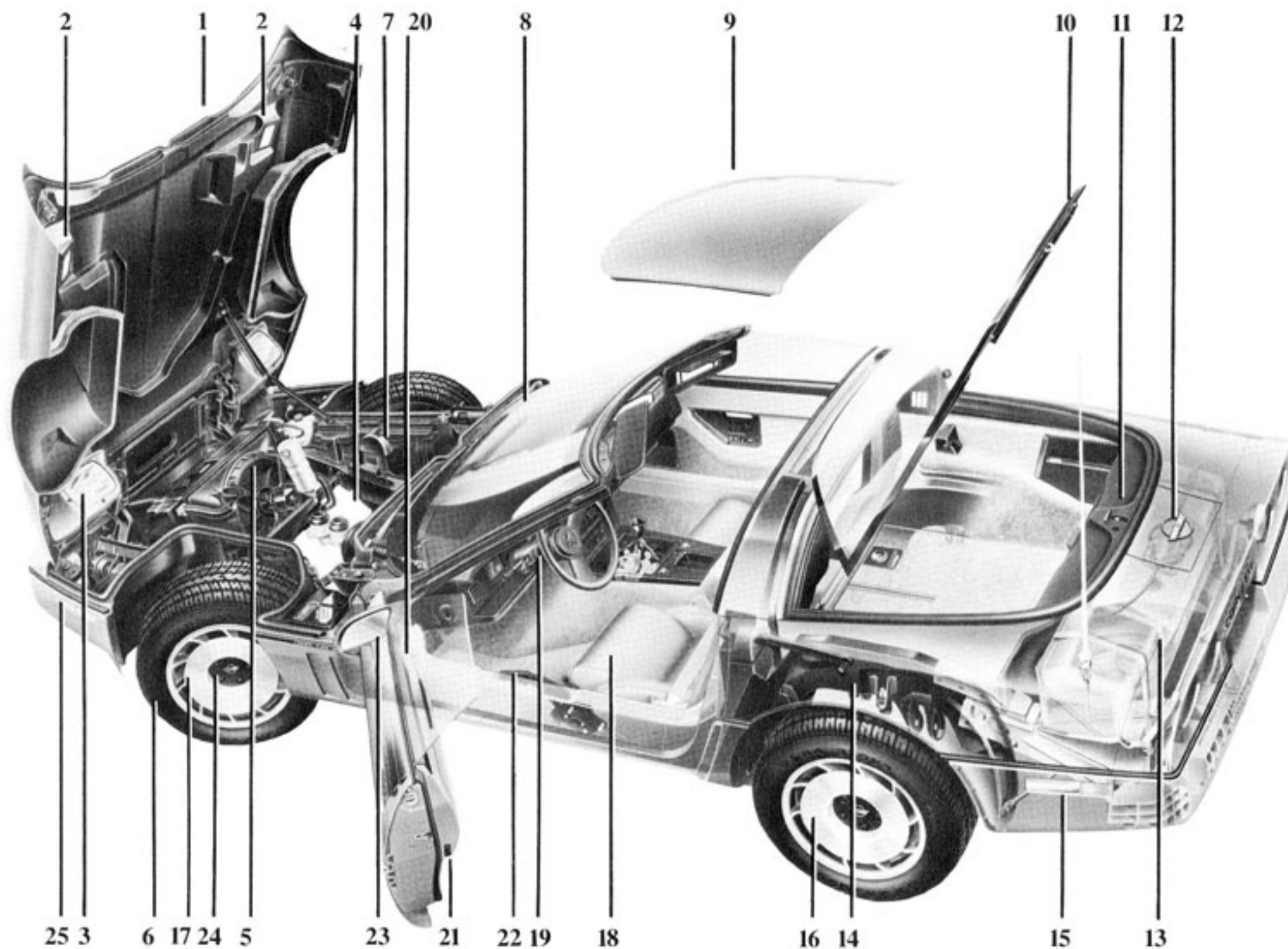

14. Five-link independent rear suspension with transverse fiberglass spring
15. Rear cornering lamps
16. Cast alloy wheels 15" x 7" front, 15" x 7 1/2" rear standard; 16" x 8 1/2" available. 16" x 8 1/2" front, 9 1/2" rear with Z51 Performance Handling Package (shown)

17. Four-wheel disc brakes with 11.5" rotors and finned aluminum calipers
18. Contoured reclining seats with lateral support and wool-pad comfort liner
19. Tilt-Telescopic steering wheel
20. Side window defoggers and power windows standard

21. Rear hatch release at each door and in console
22. Left-hand parking brake returns to down position after application
23. Electrically operated outside mirrors
24. Special wheel-bolt locks included with available wheels
25. Front cornering lamps

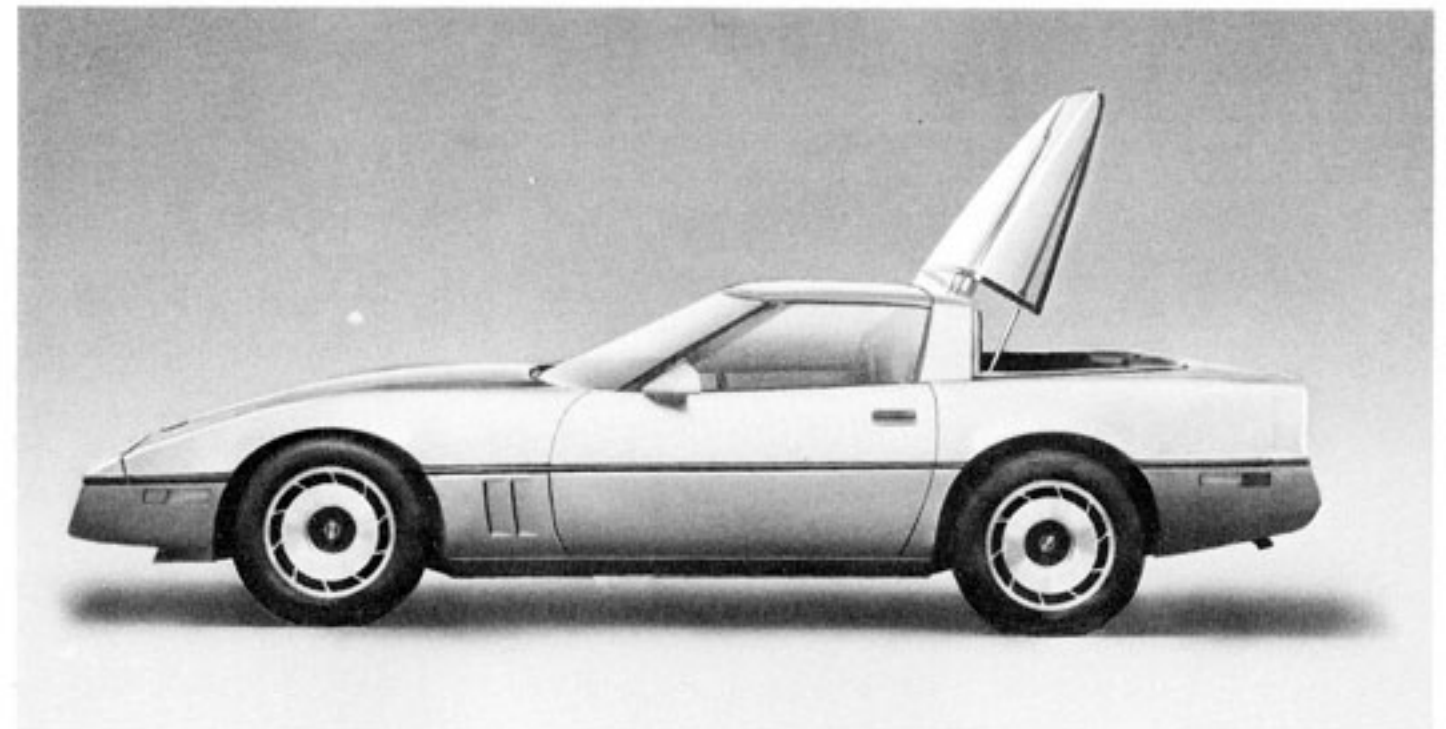
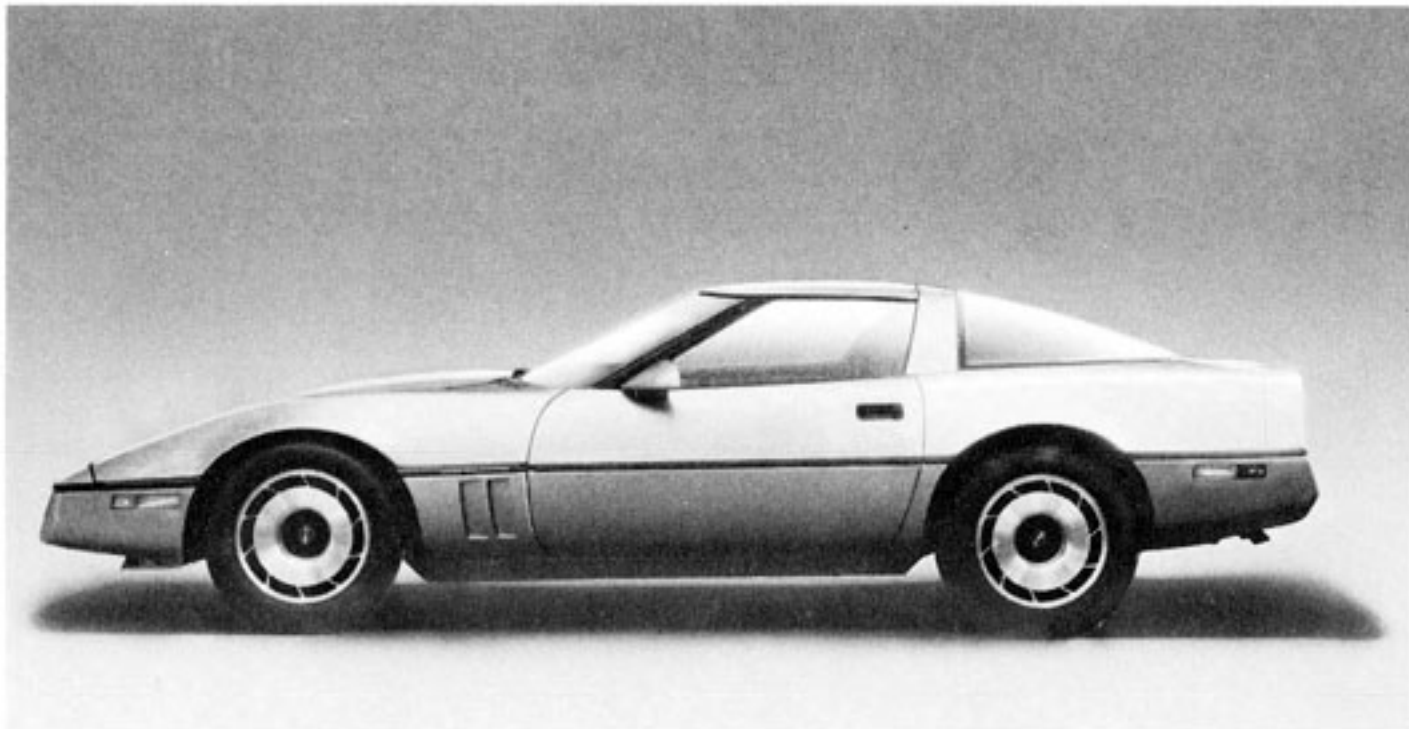

Distinctive Corvette Profile with Sharply Sloping Front End, Deeply Angled Windshield, Fastback Roof Line with Lift-up Glass Hatch and Spoiler-Type Rear Deck

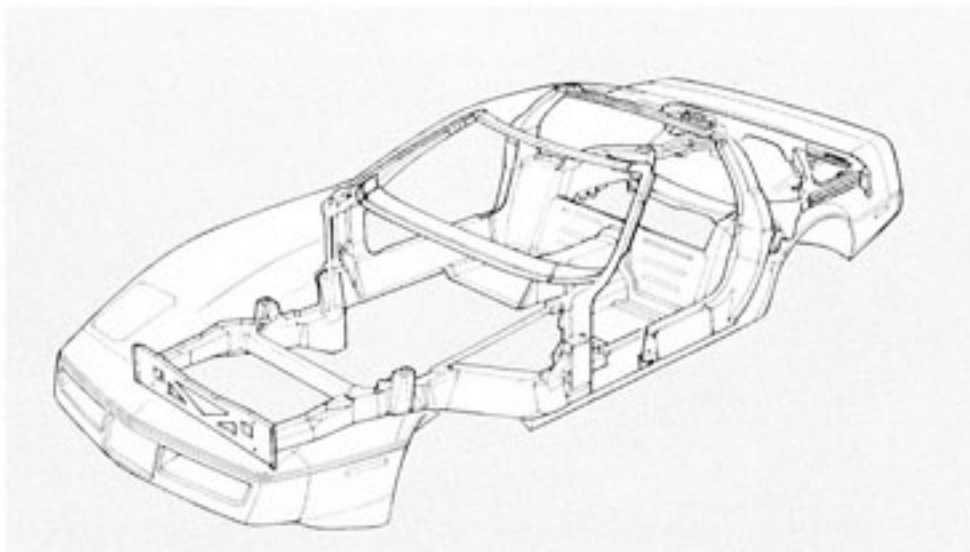

Uniframe Assembly with Excellent Beaming and Torsional Strength

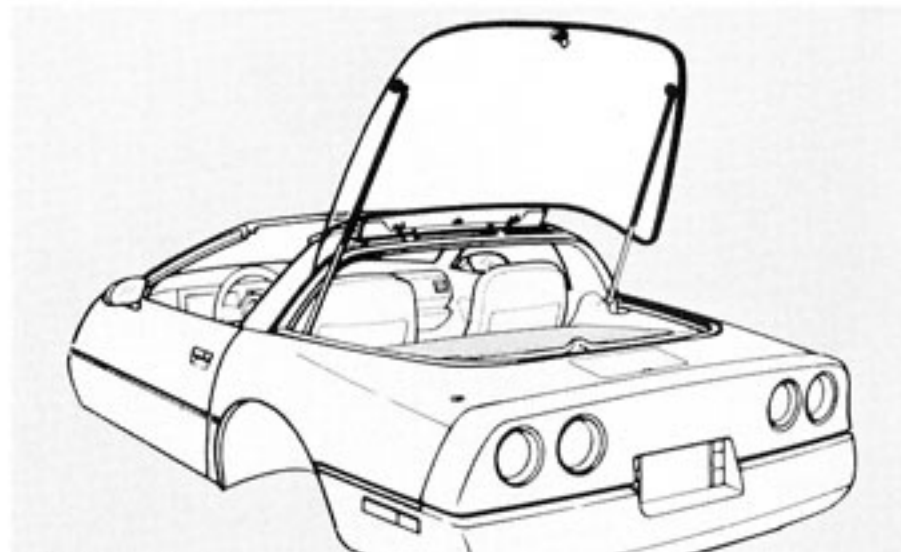

Full-Opening Rear Hatch

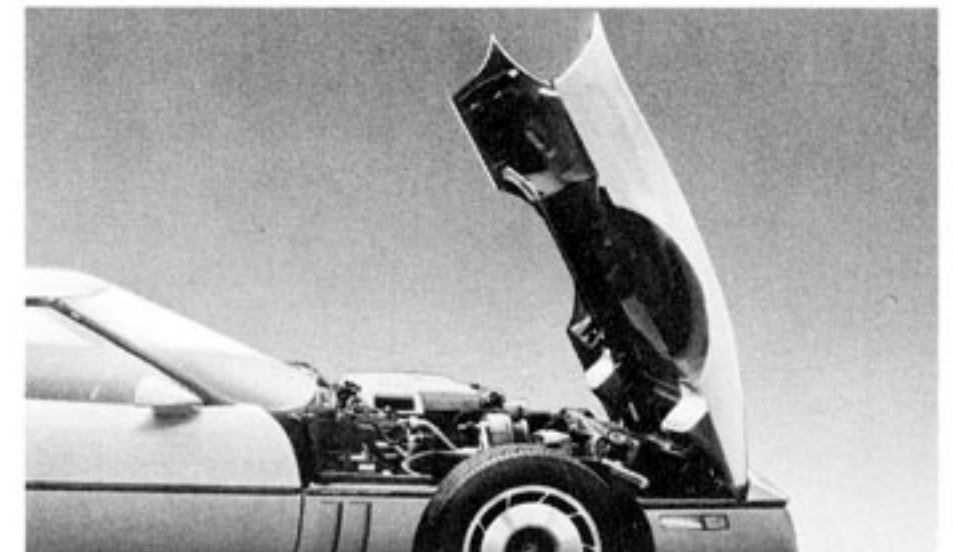

Full-Opening Clamshell Hood for Easy Engine Access

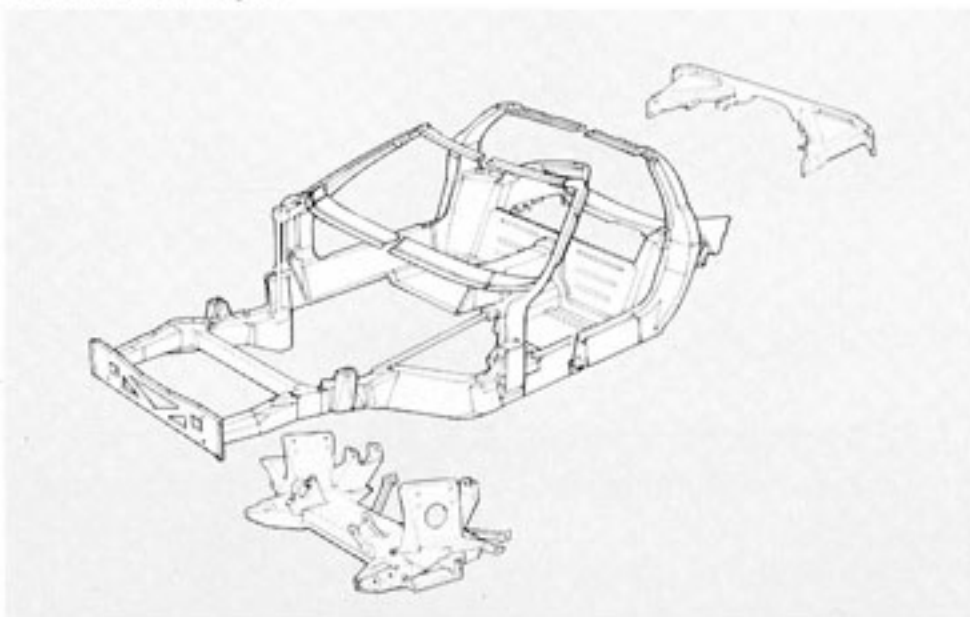

All-Welded Structure of High-Strength Steel for Rigidity

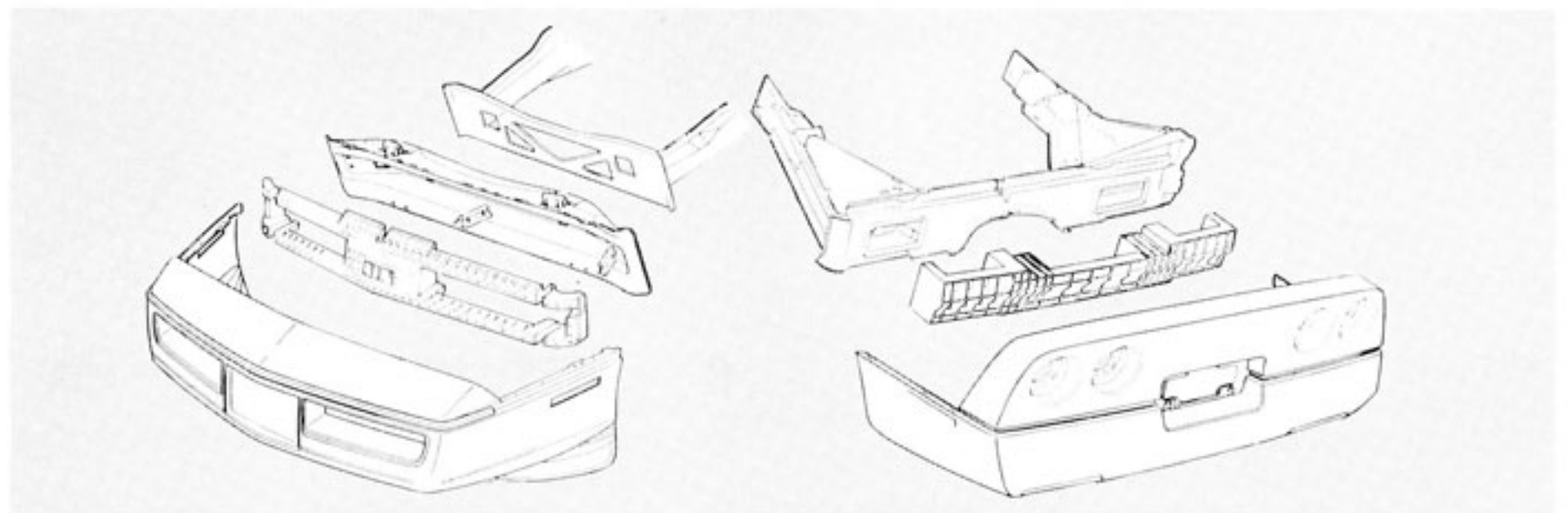

Front and Rear Full-Width Honeycomb Absorbers, Steel Backed



One-Piece Roof Panel Stores Under Hatch for Convenient and Handy Stowage



One-Piece Lift-off Roof Panel; Eliminates the T-bar Configuration

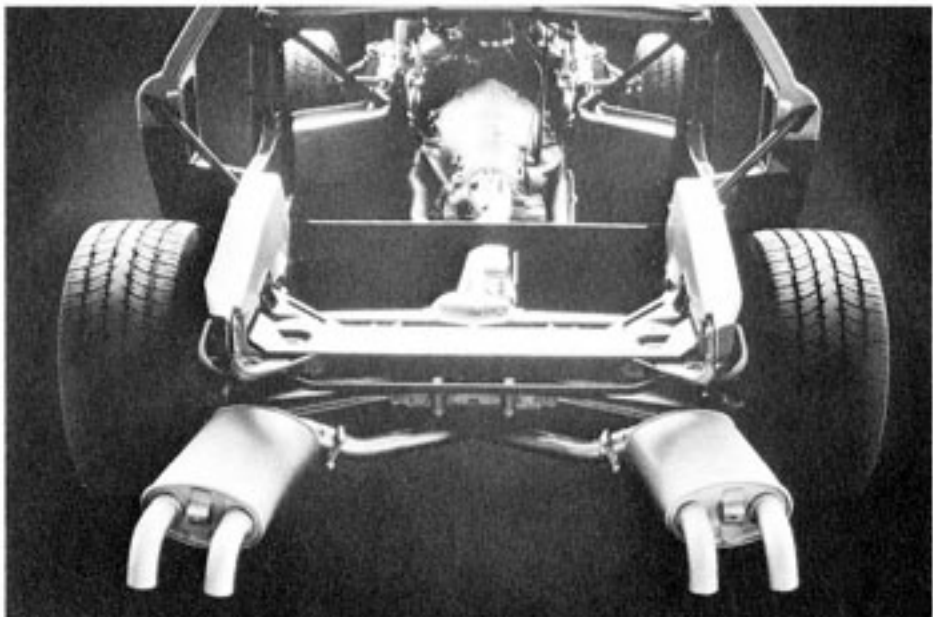

Formula I-Inspired Rear Suspension

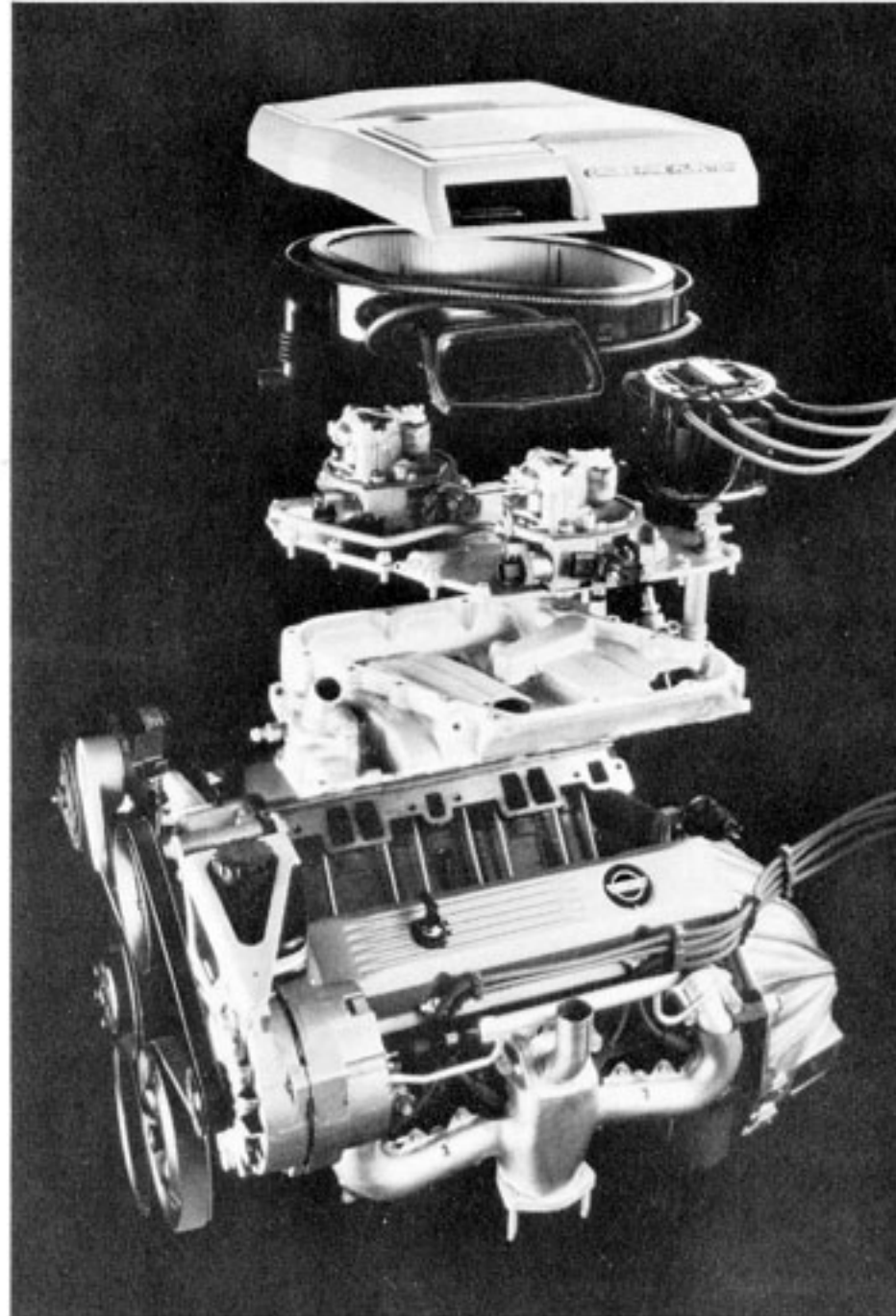

5.7 Liter (350 CID) Cross-Fire Injection V8 Engine — Exploded View, LH



Left-Hand Operated Parking Brake Returns to Downward Position after Application



Forged Aluminum Upper and Lower Control Arms and Spindles



Five-Link Rear Suspension with Transverse Glass-Epoxy Composite Spring

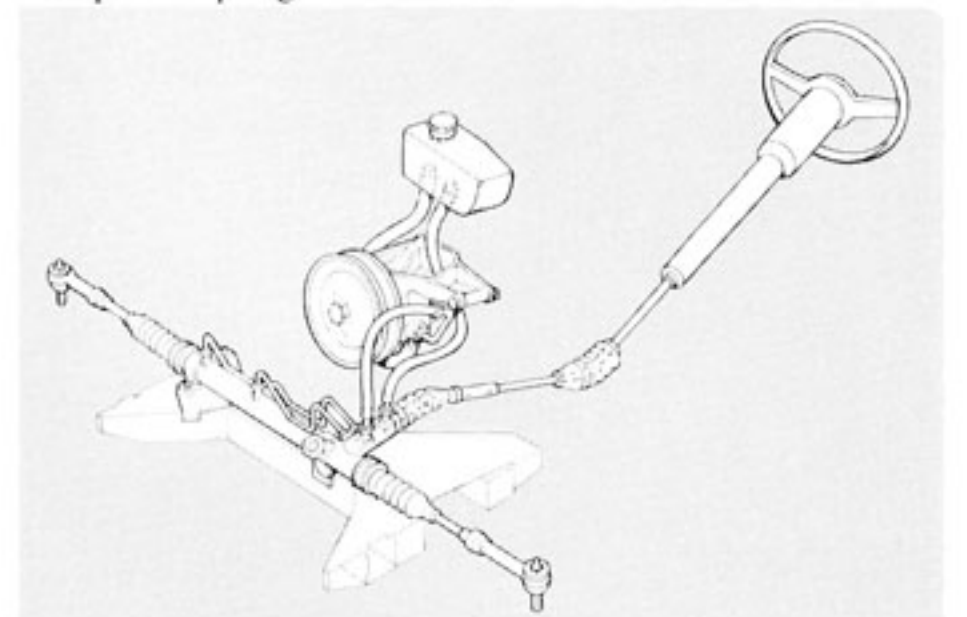

Power Rack-and-Pinion Steering. 15.5:1 Ratio Standard. 13.0:1 with Performance Handling Package.

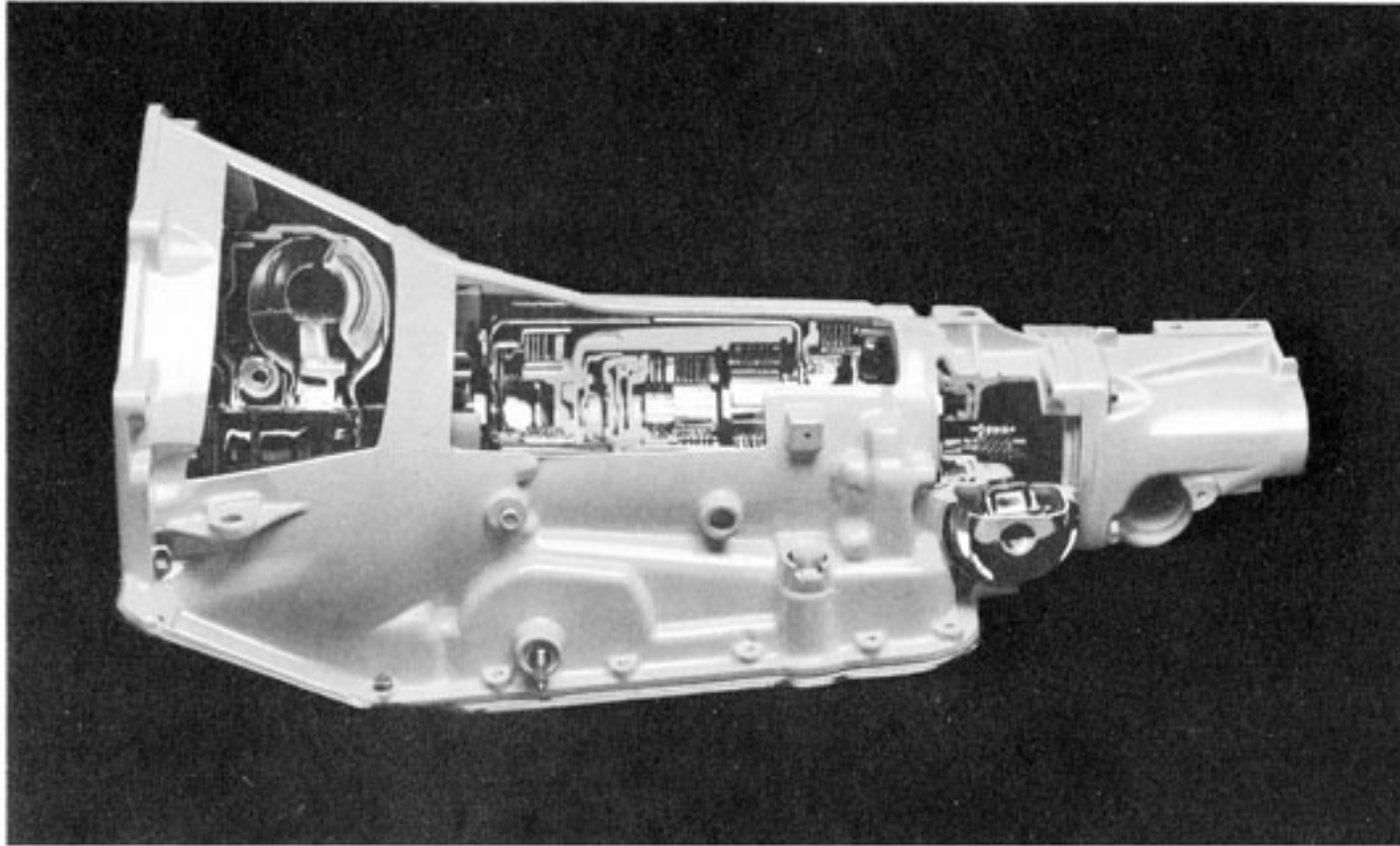

Automatic Transmission with Overdrive and Converter-Clutch Operation in Three Top Gears

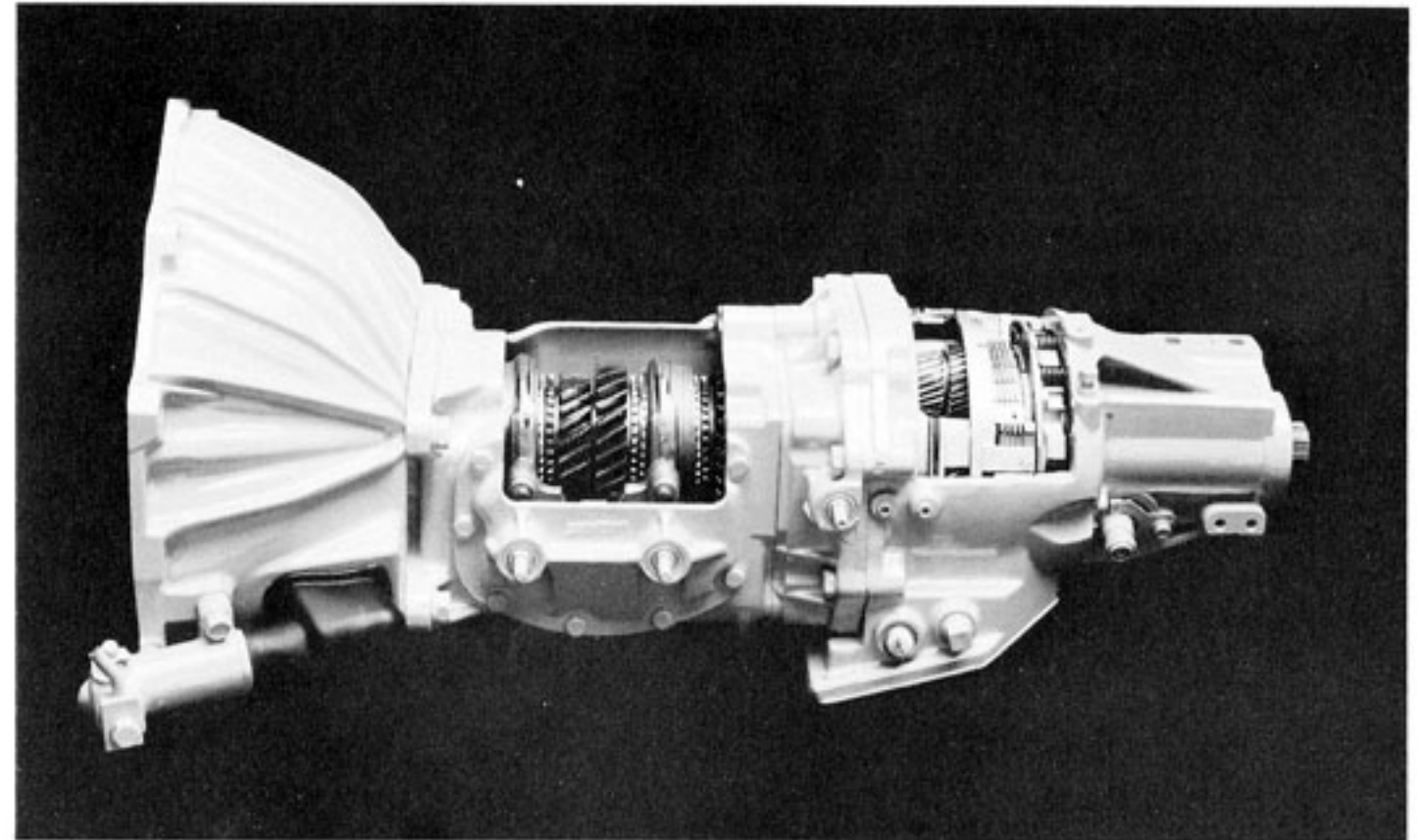

Available Four-Speed Manual with Computer-Controlled Overdrive in Three Top Gears

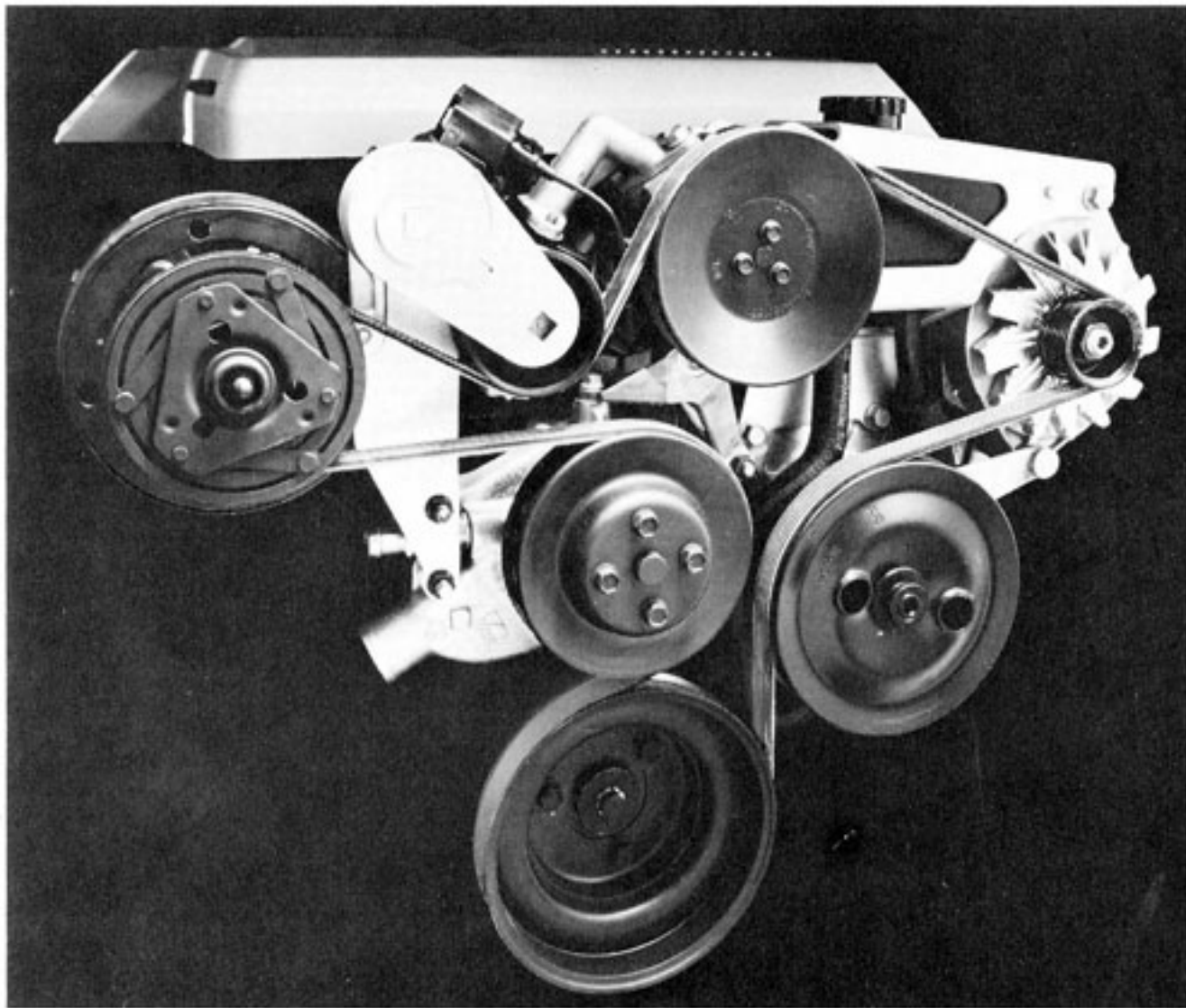

Poly-Vee Single Drive Belt System Operates Water, Air and Power Steering Pumps, Delcotron and A/C Compressor with Constant-Tension Idler



Standard 15" Cast Alloy Aluminum Wheels



Optional 16" Cast Alloy Aluminum Wheels

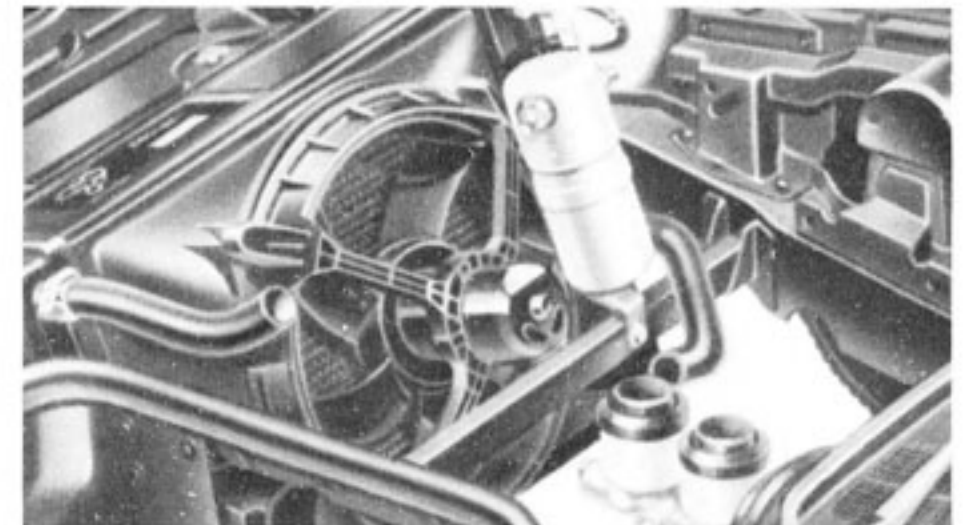

Temperature-Controlled Cooling Fan Operates Below 35 MPH When Needed Under Normal Conditions

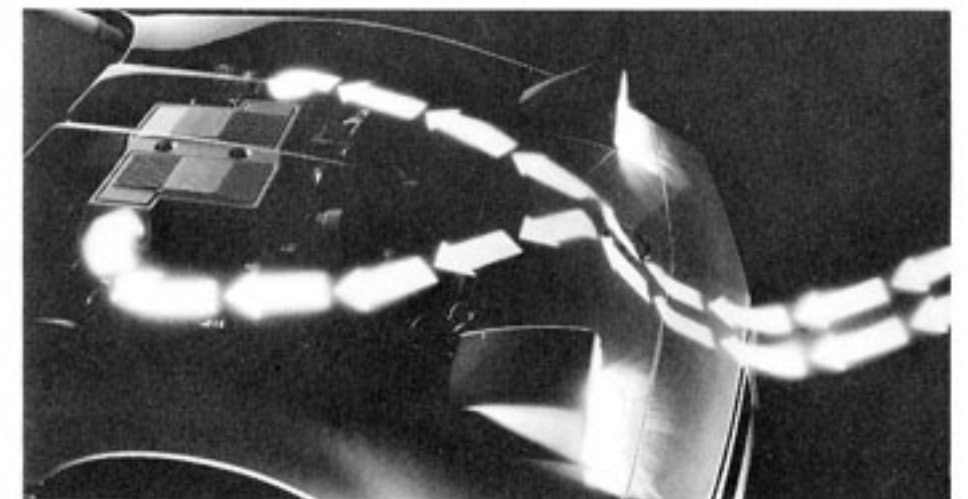

Integral Hood Ducts Direct Air into Air Cleaner

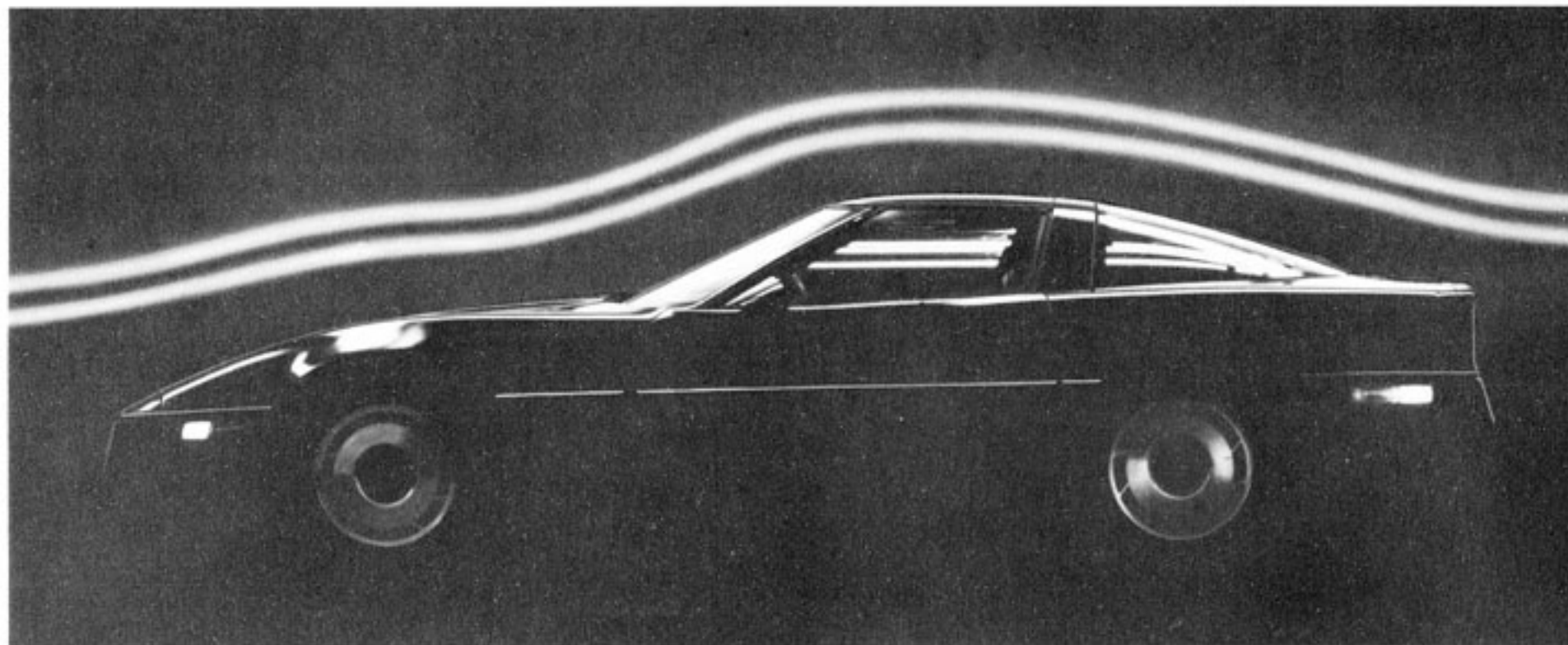

An Aerodynamic Shape with 23% improvement over 1982

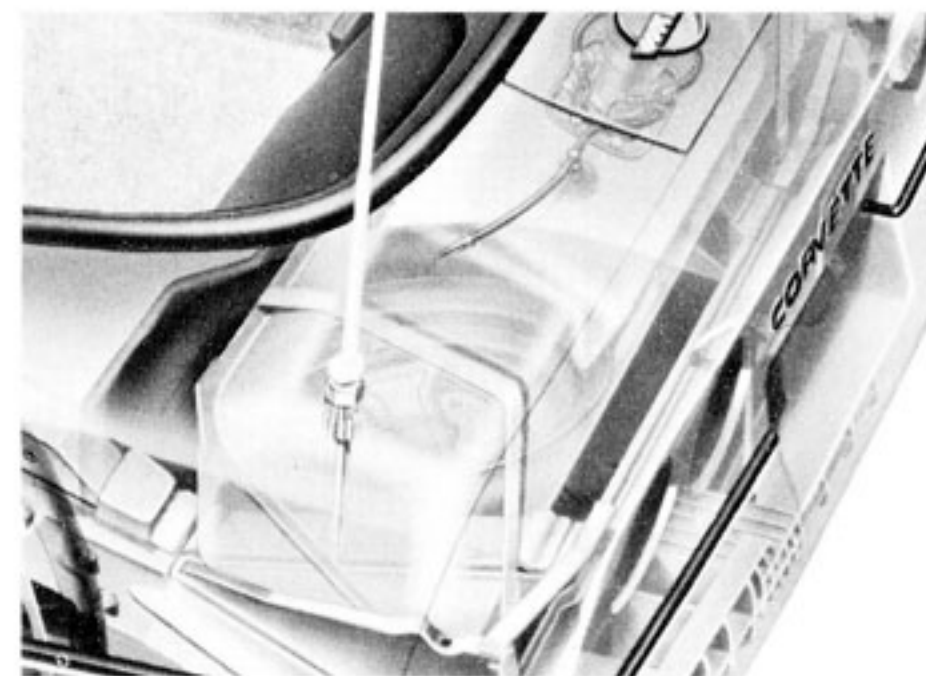

20-gallon Fuel Tank with Cap Concealed Under Door

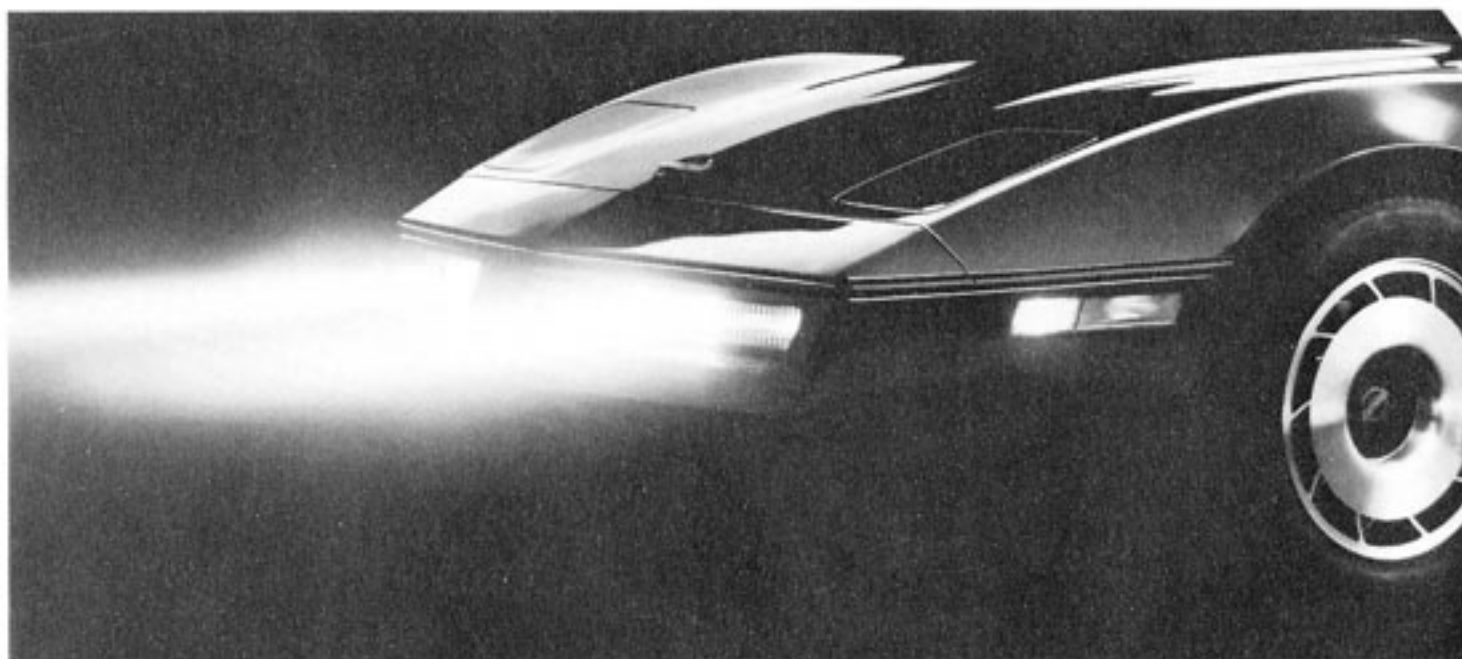

Halogen Fog Lamps Are Hinged to Fold Back on Slight Impact



Electrically Controlled Rearview Mirrors for Both Sides

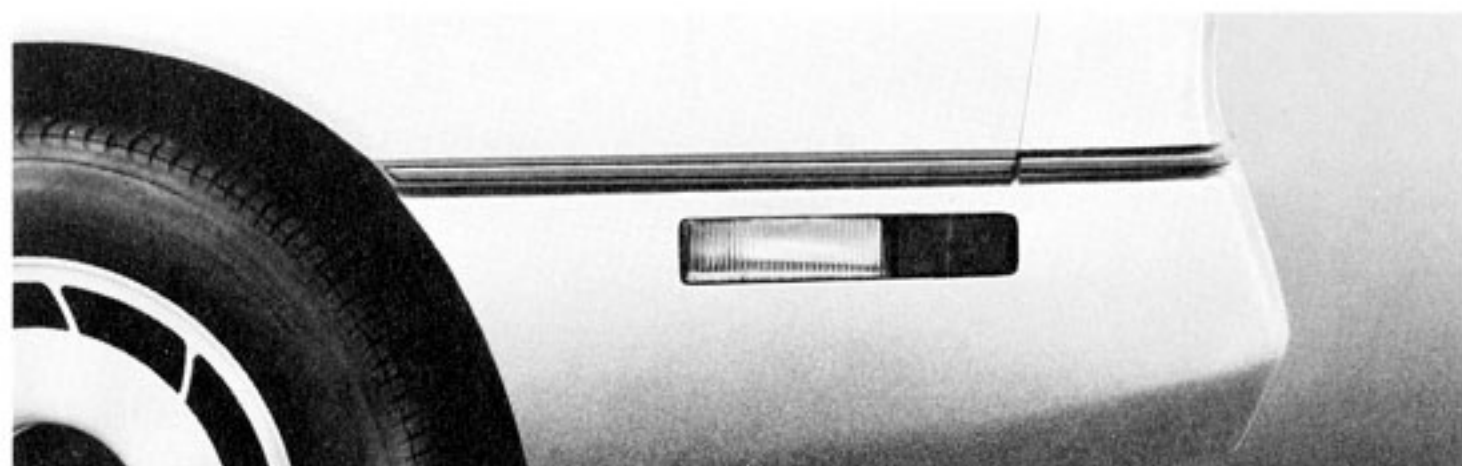

Rear Cornering Lamps

CORVETTE

Hatchback Coupe

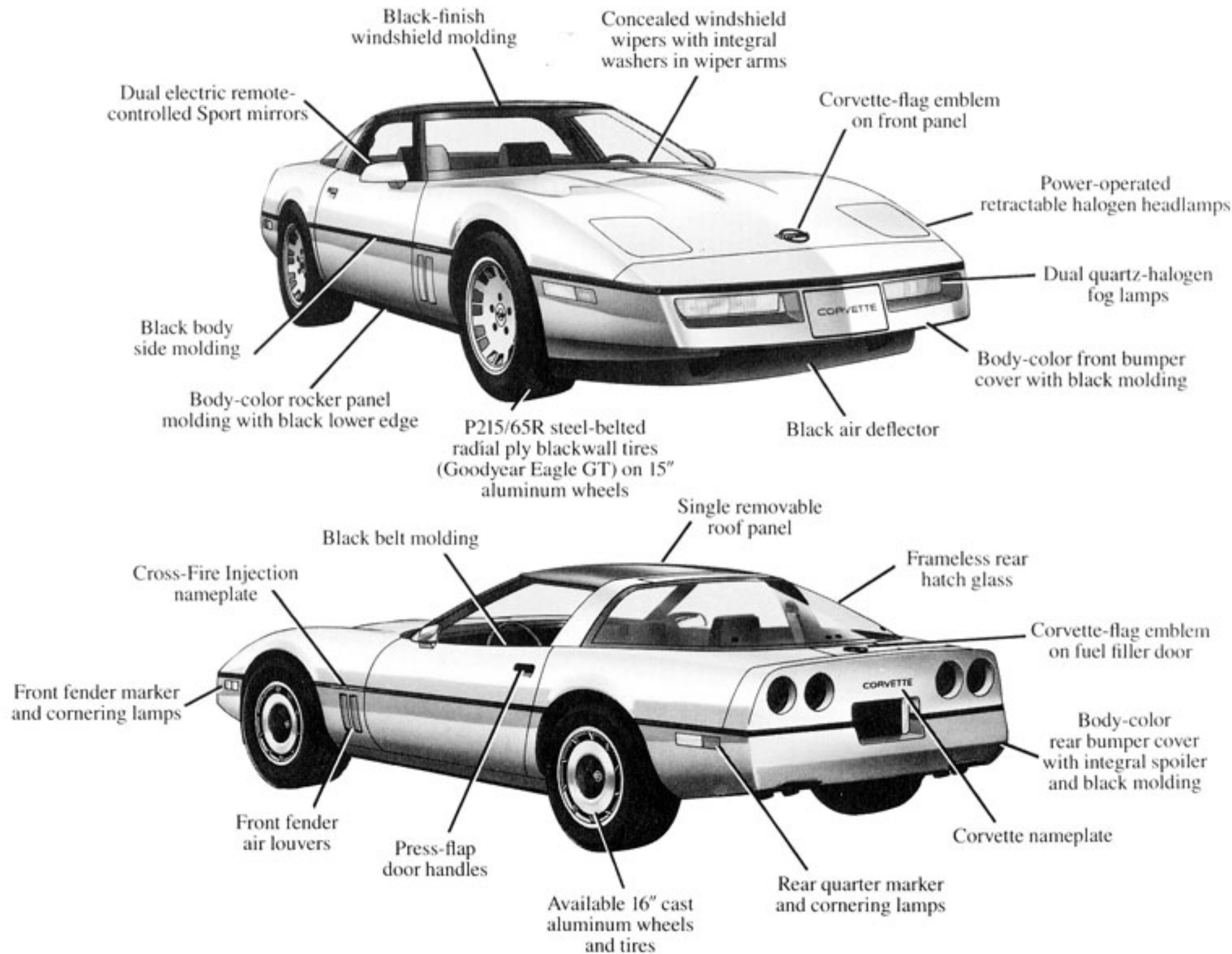

Standard 15" cast aluminum wheels with 7"-wide rims in front: 7½" in rear. P215/65R-15 Eagle GT blackwall tires.



Available 16" cast aluminum wheels with 8½"-wide rims and P255/50VR-16 Eagle VR50 blackwall tires. With Performance Handling Package (RPO Z51), front wheels are 8½" wide; 9½" wide in rear and have same P255/50VR-16 Eagle VR50 blackwall tires.



Corvette Standard Cloth Bucket Seats



Corvette Available Leather Bucket Seats



Corvette Available Custom Adjustable Sport Seats



Corvette Hatchback Coupe Front Styling



Corvette Hatchback Coupe Rear Styling

INTERIOR FEATURES

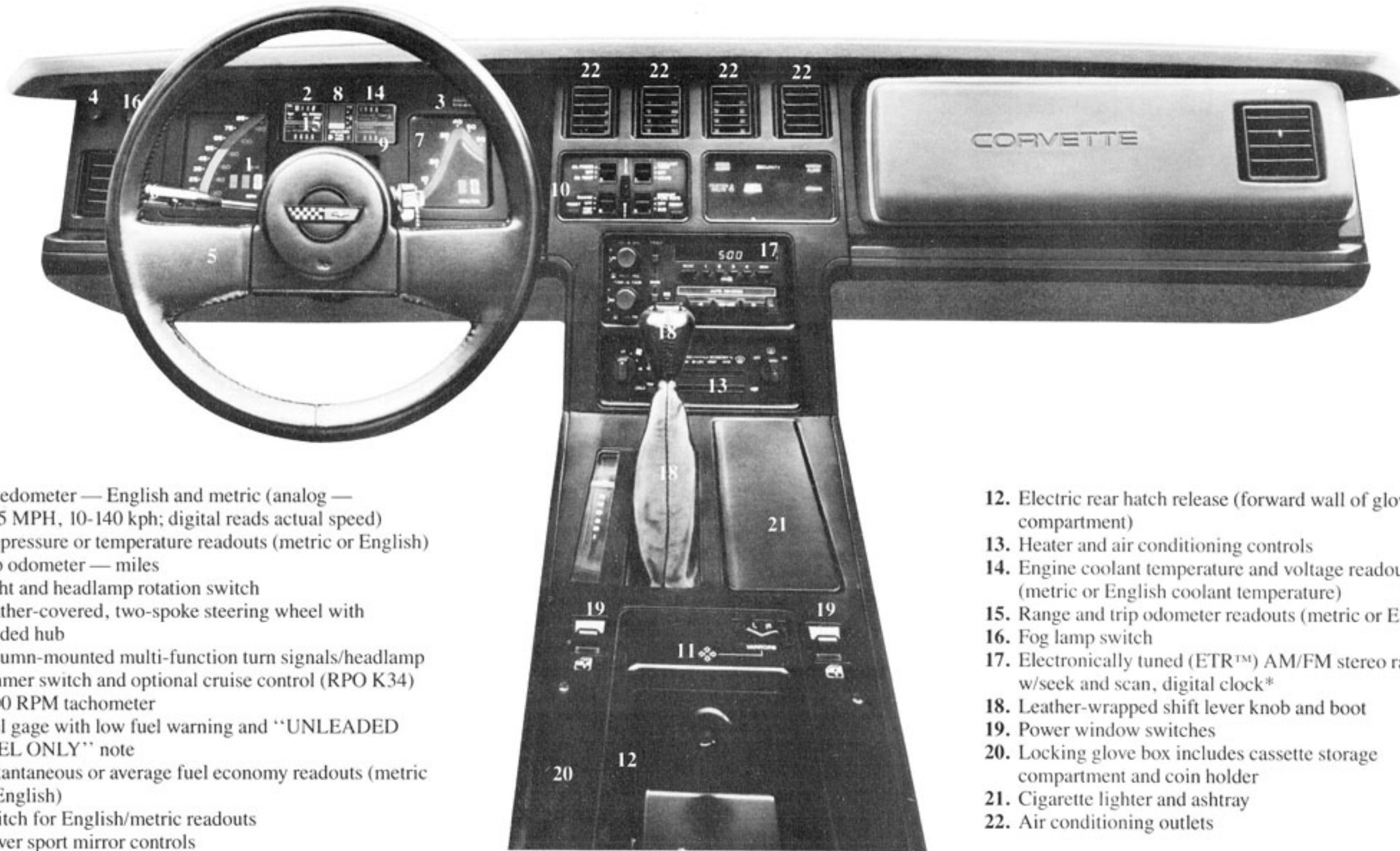

1. Speedometer — English and metric (analog — 5-85 MPH, 10-140 kph; digital reads actual speed)
2. Oil pressure or temperature readouts (metric or English)
3. Trip odometer — miles
4. Light and headlamp rotation switch
5. Leather-covered, two-spoke steering wheel with padded hub
6. Column-mounted multi-function turn signals/headlamp dimmer switch and optional cruise control (RPO K34)
7. 6000 RPM tachometer
8. Fuel gage with low fuel warning and "UNLEADED FUEL ONLY" note
9. Instantaneous or average fuel economy readouts (metric or English)
10. Switch for English/metric readouts
11. Power sport mirror controls

12. Electric rear hatch release (forward wall of glove compartment)
13. Heater and air conditioning controls
14. Engine coolant temperature and voltage readouts (metric or English coolant temperature)
15. Range and trip odometer readouts (metric or English)
16. Fog lamp switch
17. Electronically tuned (ETR™) AM/FM stereo radio w/seek and scan, digital clock*
18. Leather-wrapped shift lever knob and boot
19. Power window switches
20. Locking glove box includes cassette storage compartment and coin holder
21. Cigarette lighter and ashtray
22. Air conditioning outlets

*May be deleted for credit

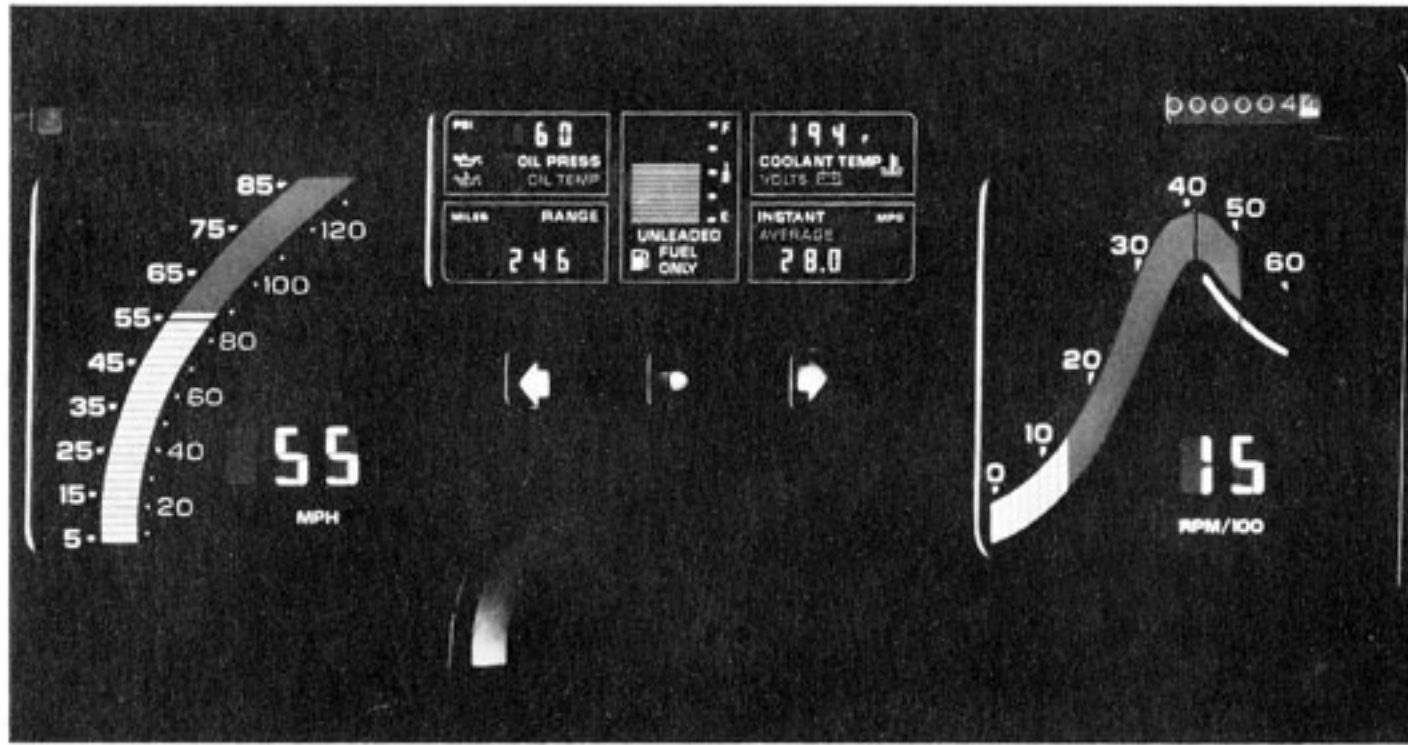

Full LCD Readout Instrumentation — English

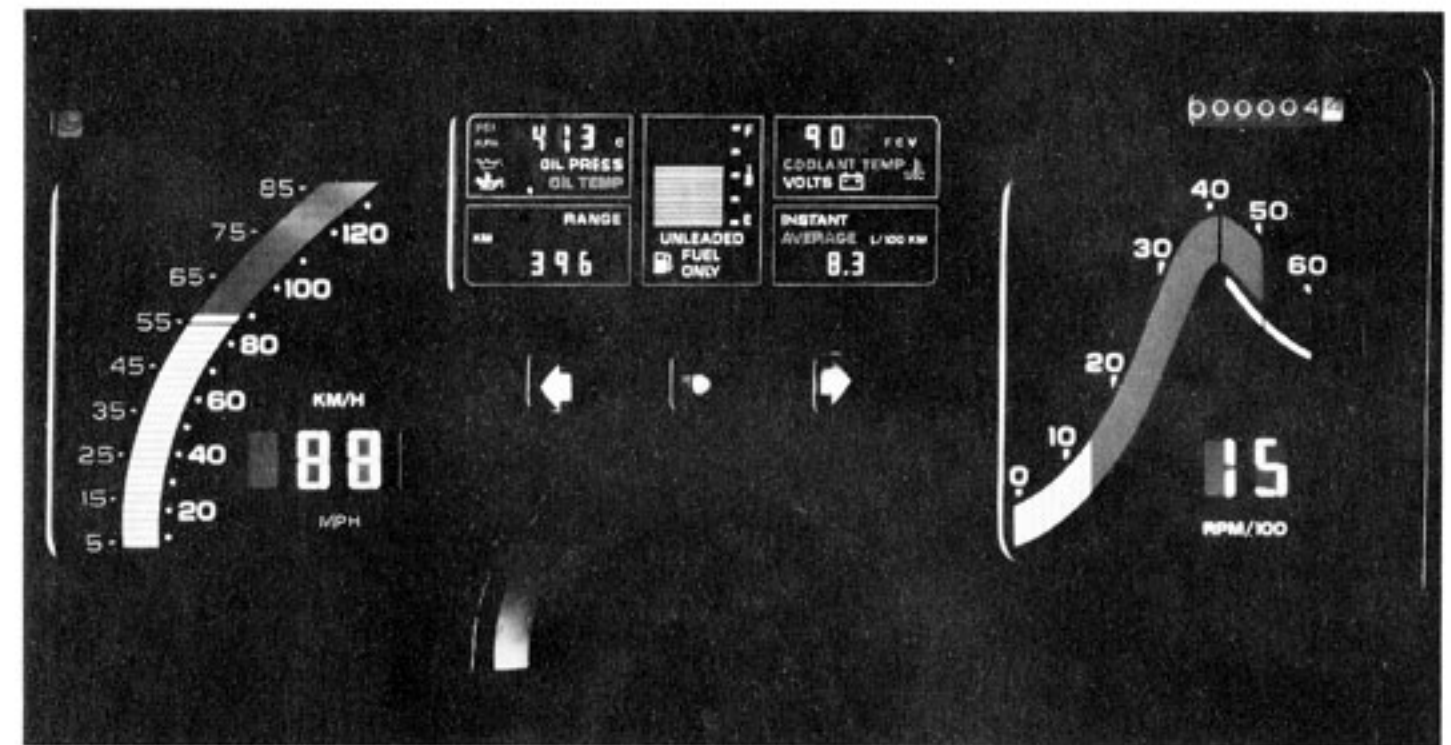

Full LCD Readout Instrumentation — metric

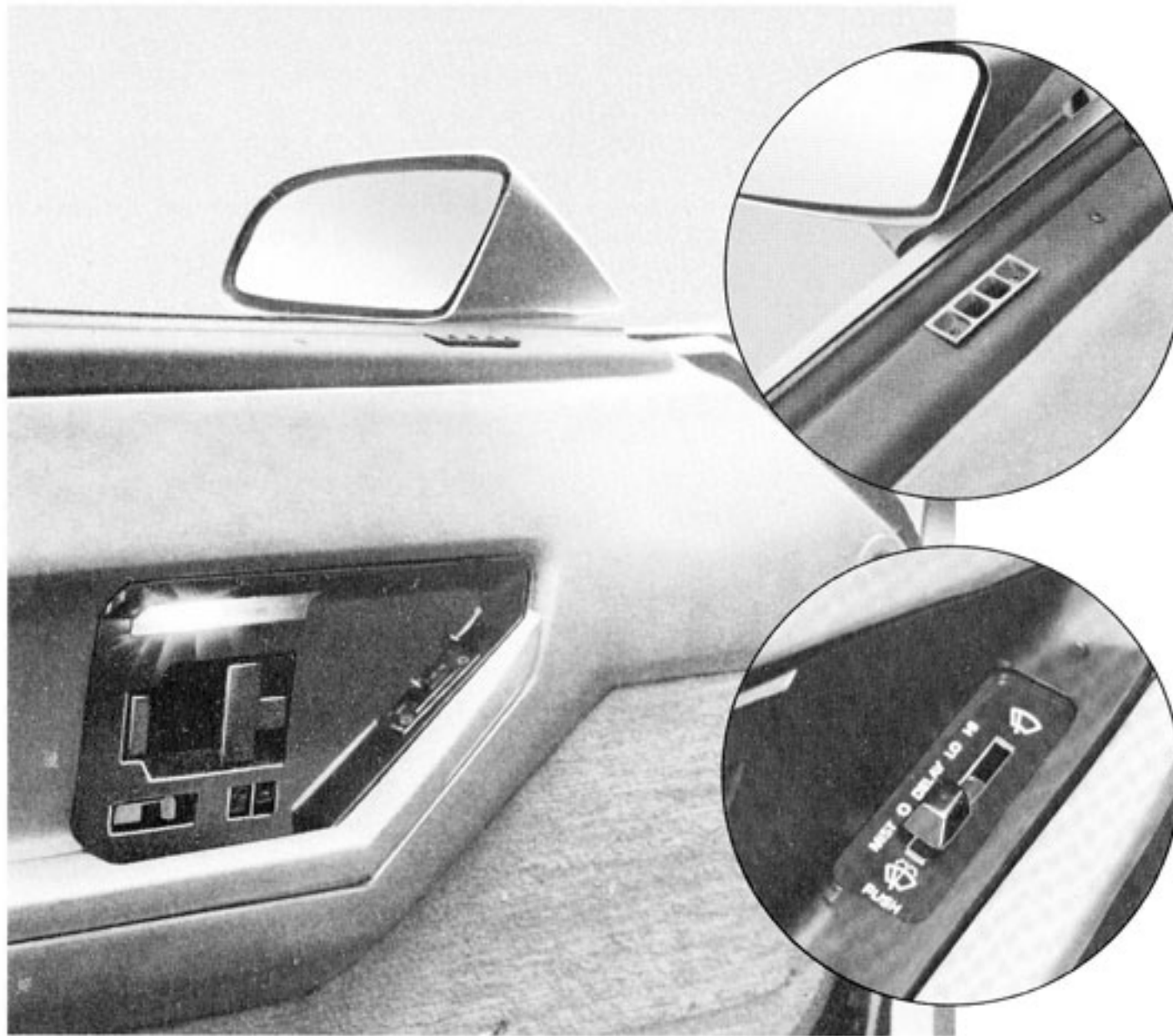

Door-Mounted Map Light, Side-Window Defoggers and Wiper/Washer Control

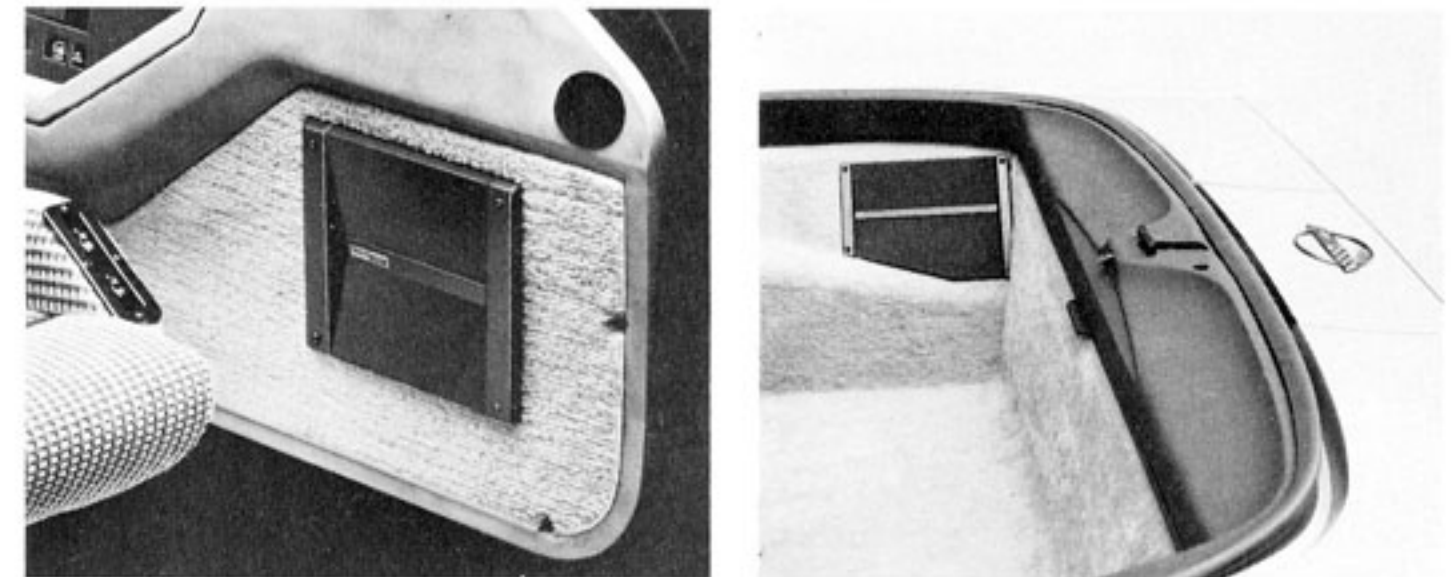

Delco-GM/Bose Music System with Door- and Quarter-Panel Speakers Available



Roller-Shade Security Screen/Cargo Cover for Storing Valuables out-of Sight



Rear Hatch Release in Console and at Rear Edge of Doors

SEAT & DOOR TRIM



Standard Cloth Reclining Bucket Seats with Wool-Pad Comfort Liner. Six-way driver's-side power available.

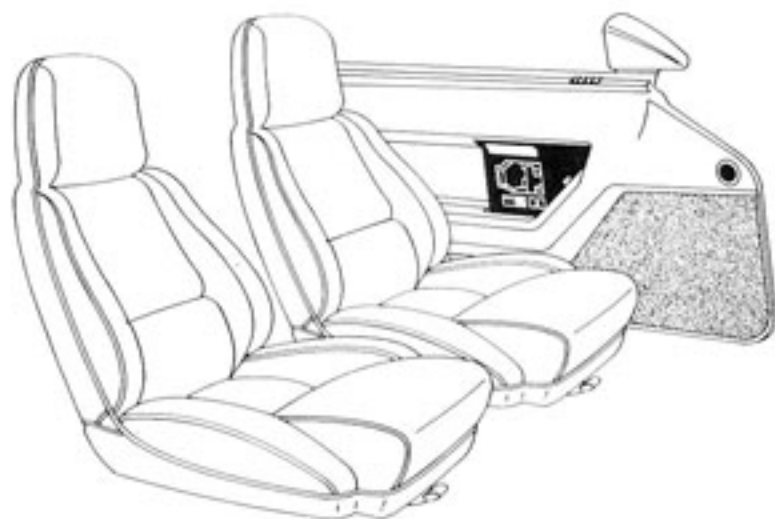

Optional Full-Leather Reclining Bucket Seats with Wool-Pad Comfort Liner. Six-way driver's-side power available.



Optional Custom Adjustable Sport Seats with Wool-Pad Comfort Liner. Six-way driver's-side power available.

COLOR AND TRIM COMBINATIONS

INTERIOR COLORS		Type/Code†	BLUE	BRONZE	GRAPHITE	GRAY	DARK RED	SADDLE
Standard Bucket Seats	Cloth (16)		X	X	X	X		X
Optional Bucket Seats	Leather(17)			X	X	X	X	X
Optional Custom Adjustable Sport Seats	Cloth (18)		X	X	X	X		X
EXTERIOR COLORS		CODE						
CORVETTE SILVER (METALLIC)		16			X	X		
CORVETTE GRAY (METALLIC)		18			X	X		
CORVETTE LIGHT BLUE (METALLIC)		20	X					
CORVETTE MEDIUM BLUE (METALLIC)		23	X					
CORVETTE RED		33			X		X	X
CORVETTE WHITE		40	X		X	X	X	X
CORVETTE BLACK		41			X	X	X	X
CORVETTE GOLD (METALLIC)		53						X
CORVETTE LIGHT BRONZE (METALLIC)		63		X				
CORVETTE DARK BRONZE (METALLIC)		66		X				
CUSTOM TWO-TONE COLORS (RPO D84)								
LIGHT BLUE (METALLIC)/ MEDIUM BLUE (METALLIC)			X					
LIGHT BRONZE (METALLIC)/ DARK BRONZE (METALLIC)				X				
SILVER (METALLIC)/ GRAY (METALLIC)					X	X		

†Number codes shown above are keyed to exterior colors and interior fabrics shown in Color and Trim section.



OPTIONAL CUSTOM ADJUSTABLE SPORT SEATS

Both driver and passenger seats feature full power adjustment for lumbar, backrest and backrest bolster adjustments to provide a high degree of versatility for practically every human form. Three separate lumbar supports for the lumbar region are controlled by internal bladder-type cells, powered by an air pump. These cells can be inflated or deflated to give the degree of pressure desired, especially on long drives. Lateral adjustment of the seat-back sides is controlled by a side-bolster power switch. This allows occupants to adjust the backrest sides to a comfortable degree of snugness. Back angle has a 12-degree adjustment range. Separate six-way power adjustment for the driver's side only is available; fore and aft adjustment is 6.5 inches, with up and down travel of approximately 1.5 inches.

OPTIONAL FEATURES

(Available at extra cost)

FACTORY-INSTALLED OPTIONAL EQUIPMENT RPO

- Defogger System.** Includes rear window defogger and heated outside rearview mirrors ... Z6A
- Door Lock System, Power** AU3
- Paint, Custom Two-Tone.
(See Color and Trim Section) D84
- Radiator, Heavy-Duty** VO1
- Radio Equipment:** Includes power antenna.
Electronically Tuned AM/FM Stereo with Seek-Scan, Cassette Tape and Clock..... UM6
- Citizens Band Radio, NA with UU8 UN8
- Delco-GM/Bose Music System, Electronically Tuned AM/FM Stereo with Seek-Scan, Cassette Tape and Clock..... UU8
- Radio Delete (for credit; deletes std. radio and speakers) UL5
- Seat, Power, Six-Way.** Driver's side only AG9
- Speed Control, Electronic.**
With resume speed K34
- Suspension Equipment:**
Performance Handling Package. Includes QZD tires, selected special lower control arm bushings, shocks, heavy-duty front and rear springs and stabilizer bars, fast-ratio steering 13:1, aluminum propeller shaft and 3.31 rear-axle ratio Z51
- Tires:**
P255/50VR-16 Steel-Belted Radial Ply Blackwall Goodyear Eagle GT. Includes 16-inch aluminum wheels QZD
- Trim, Interior.**
(See page 12 and Color and Trim Section)

DEALER-INSTALLED ACCESSORIES

- Cloth, Polishing
- Compass
- Container, Litter & Tissue Dispenser
- Heater, Engine Block
- Lamp, Spotlight



Pressure-sensitive Power Door Lock System



Electronic Speed Control with Resume Speed



Defogger System: Includes Rear Window Defogger and Heated Outside Rearview Mirrors

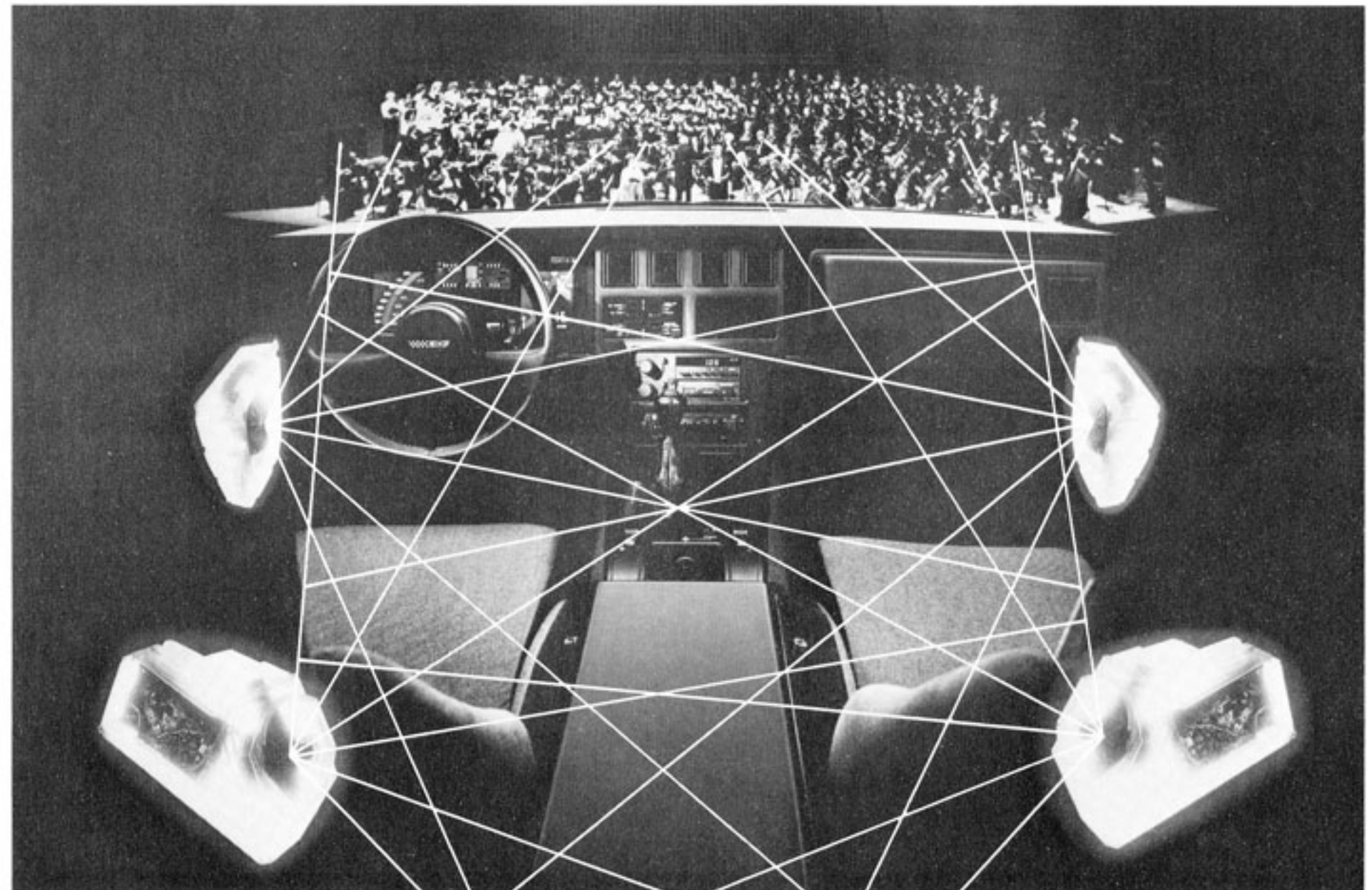

Delco-GM/Bose Music System, Electronically Tuned AM/FM Stereo Radio with Seek and Scan, Cassette Tape and Clock

See Dealer Order Guide for latest available information.

BODY FEATURES

A total redesign of the 1984 Corvette, coupled with the new Bowling Green, Kentucky, plant allowed for a whole new approach in dedication to quality by designers, engineers, talented workers and managers. Total commitment and pride in workmanship are evident throughout the entire building process.

A Match Check Frame is a key part of carrying the quality commitment to completion. It serves as a full-size "blueprint" used to check every structural part. And these parts must be built to minute tolerances.

The two-stage automatic welder produces a skeleton as it "builds" the Corvette uniframe automatically, applying 142 precision welds in a matter of 97 seconds. It's a state-of-the-art engineering marvel that creates a solid structure with built-in dimensional stability.

This uniframe design is lighter, significantly stiffer in beaming, plus torsional characteristics are improved. All steel substructure will be extensively treated and coated to inhibit corrosion. Dash, plenum, front and rear underbody panels, door sealing panel and roof and quarter panel are adhesively bonded to the

uniframe. Front-end panel will be bolted on for improved panel fit and repairability. The removable roof panel is attached at all four corners to maximize its structural contribution. Exposed bond seams are eliminated.

A solid fiberglass body continues to be one of the most enduring qualities of Corvette. Now, in the new plant, advanced techniques have honed fiberglass construction, and a smoother degree of beauty than ever before achieved.

Energy-absorbing front and rear bumper systems feature Guideflex® honeycomb construction.

All colors are formulated with high-solids acrylic enamel base. For a good match between body and front and rear "soft" facias, the base coat will be common. This is an innovation, starting with the 1984 Corvette. Base coat non-metallic colors will also be common between body and facias. All colors will be finished with a clear coat.

The chassis, drive train and suspension are married to the body in a specially built new hydraulic "towveyer"

interlocking system which helps assure that every contact point will match.

Application of computer technology at Bowling Green is among the highest in the industry. There are computers to double-check the computer. CRT terminals are used for inventory control, part location/delivery, manpower control, and quality control. Computer-generated inspection tickets follow a new Corvette throughout the assembly process. Even the front-suspension and rear-wheel alignment on the new Corvette is computerized for precise accuracy.

Each day there is a "Morning Audit." Salaried and hourly employees meet to examine cars in detail. They discuss quality reports from the previous day's production and consider any ideas that might lead to improvements. They search for ways to assure and enhance the quality of Corvette.

It is typical of the attention to detail in evidence throughout the plant. Here, we've assembled talented workers and some of the most modern production equipment available today. And it is *the* Corvette plant. One plant, one group of people, dedicated to building one brand, one model, at a deliberate pace of just a few cars each hour.

For a Hushed, Quiet Ride . . .

Keeping "unwanted" sounds out of the passenger compartment is a primary goal of automotive acoustical engineers. Wind noise, road noise and other errant sounds should be kept where they belong . . . outside. However, in a GT sports car like the Corvette, the throaty sound of exhaust notes can be highly desirable. And it is this kind of balance that has been struck in the new world-class Corvette. It's a car that goes like it should, sounds like it should, but doesn't create an assault on the occupants at the same time. Flush-mounted windshield and rear window, plus

the absence of protrusions to interrupt the wind, help give the car an ability to slip through the wind with a minimum of noise. These, in addition to the inherent sound-deadening qualities of fiberglass bonded to the steel uniframe, provide an excellent base for further acoustical engineering. Various insulator pads of acoustical material literally surround the driver and passenger with a barrier against outside, unwanted sounds. The illustration on this page shows some of the materials and location of many of these lightweight, highly effective insulators.

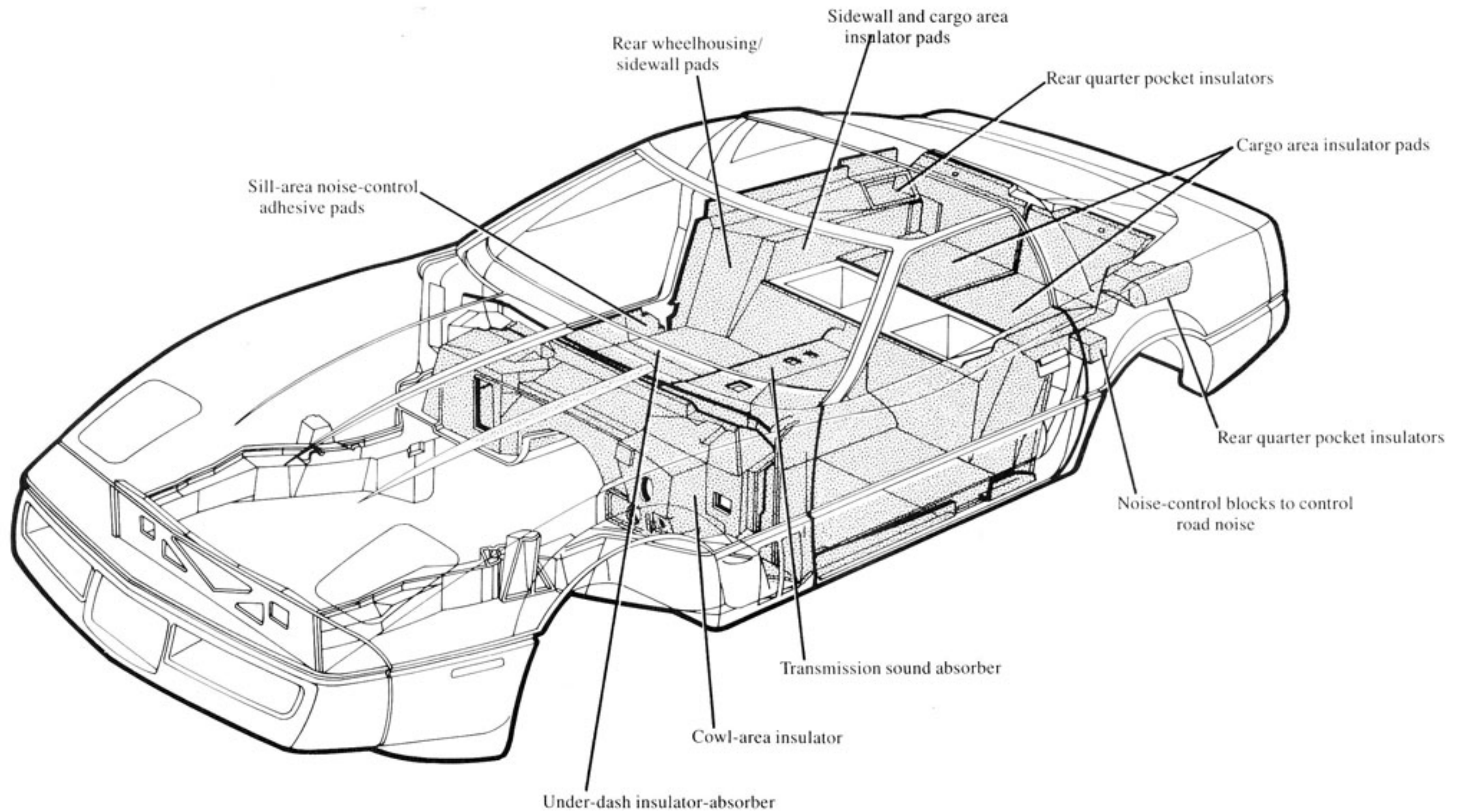

POWER TEAMS

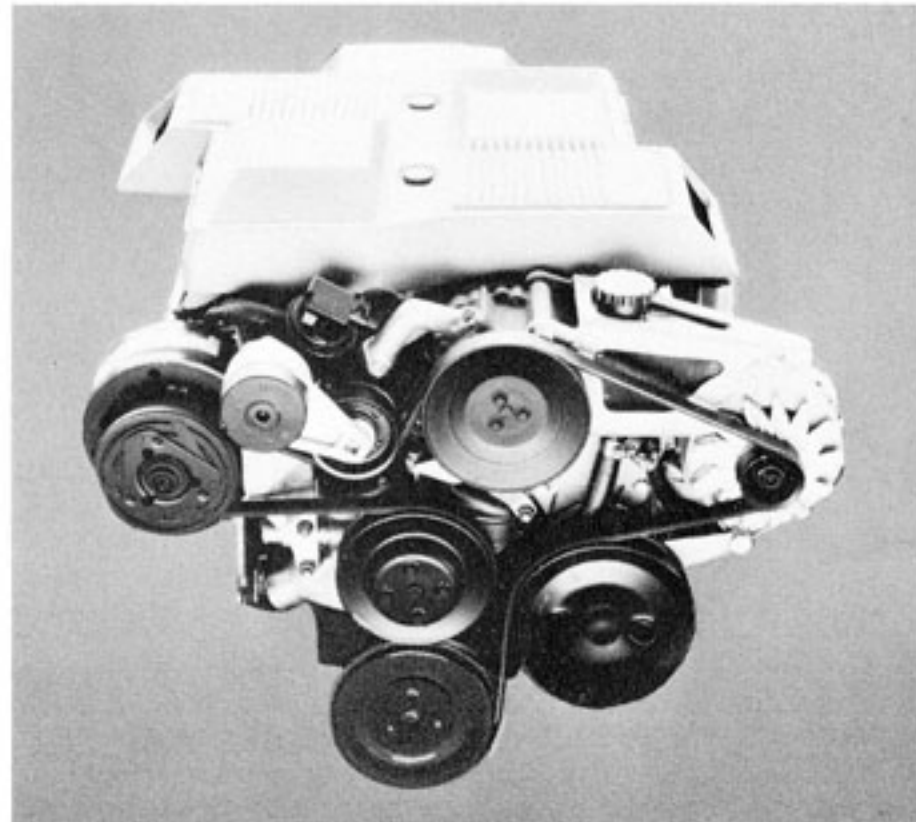

Standard 5.7 Liter Cross-Fire Injection V8

Engine	RPO No.	Power Rating*	Displacement (cubic inches)	Engine Availability	Transmission/Rear-Axle Ratios	
					Four-Speed Manual†† RPO MM4	Automatic RPO MX0

ALL STATES

5.7 Liter CFI V8**(A)	L83	205	350	Std.	3.07†	3.07†
-----------------------	-----	-----	-----	------	-------	-------

*SAE net horsepower as installed. **Cross-Fire Injection. †Axle ratio 3.31 with Z51 Performance Handling Package. ††Interim availability. Std. — Standard. See EPA section for mileage estimates.

(A) Produced by GM — Chevrolet Motor Division.

SERVICE INTERVALS*

Engine Oil.....	12 months or 7,500 miles
Oil Filter.....	12 months or 7,500 miles; every 15,000 miles thereafter
Spark Plugs.....	Up to 30,000 miles
Chassis Lubrication.....	12 months or 7,500 miles
Automatic Transmission Fluid Change.....	Every 100,000 miles

*Under normal conditions. Consult Owner's Manual for conditions requiring more frequent service intervals.

DIMENSIONS/SPECIFICATIONS

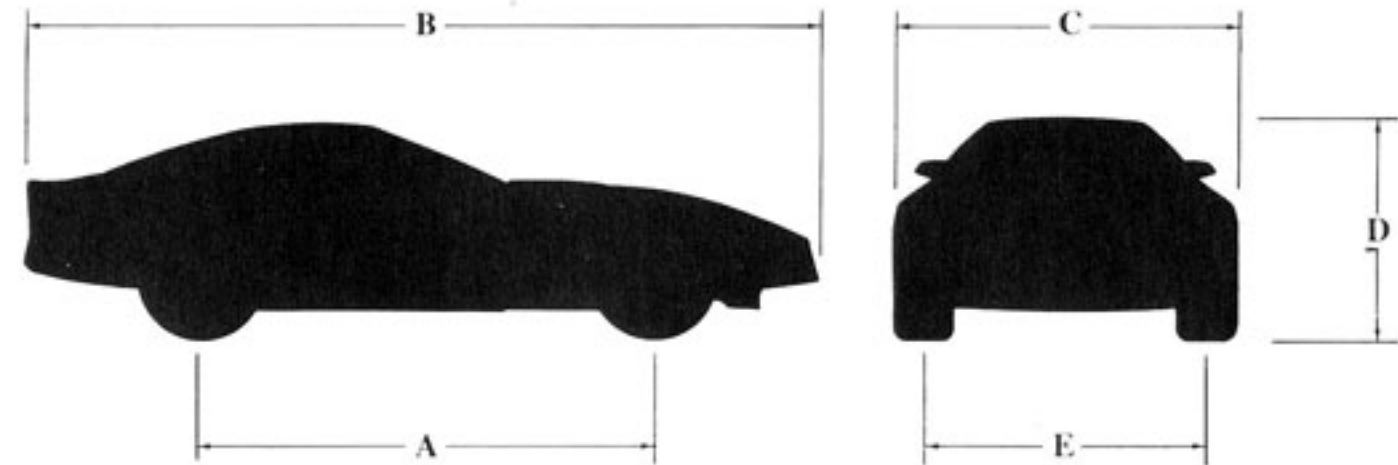

EXTERIOR DIMENSIONS (in.)

Wheelbase (A)	96.2
Length (overall) (B)	176.5
Width (overall) (C)	71.0
Height (loaded) (D)	46.7
Front tread (E)	59.6
Rear tread (E)	60.4
Minimum ground clearance	5.0

INTERIOR ROOMINESS

Head room	36.4
Leg room	42.6
Shoulder room	54.0
Hip room	49.3

LUGGAGE/CARGO COMPARTMENT

Cargo Volume (cu. ft.)	17.9
------------------------	------

FUEL TANK CAPACITY (gallons)

Fuel Tank Capacity	20.0
--------------------	------

CURB WEIGHT (pounds)

Automatic transmission models	3191
Manual transmission models	3164

1984 CORVETTE

ORDERING INFORMATION

CORVETTE Sport Coupe Model Number 1YY07

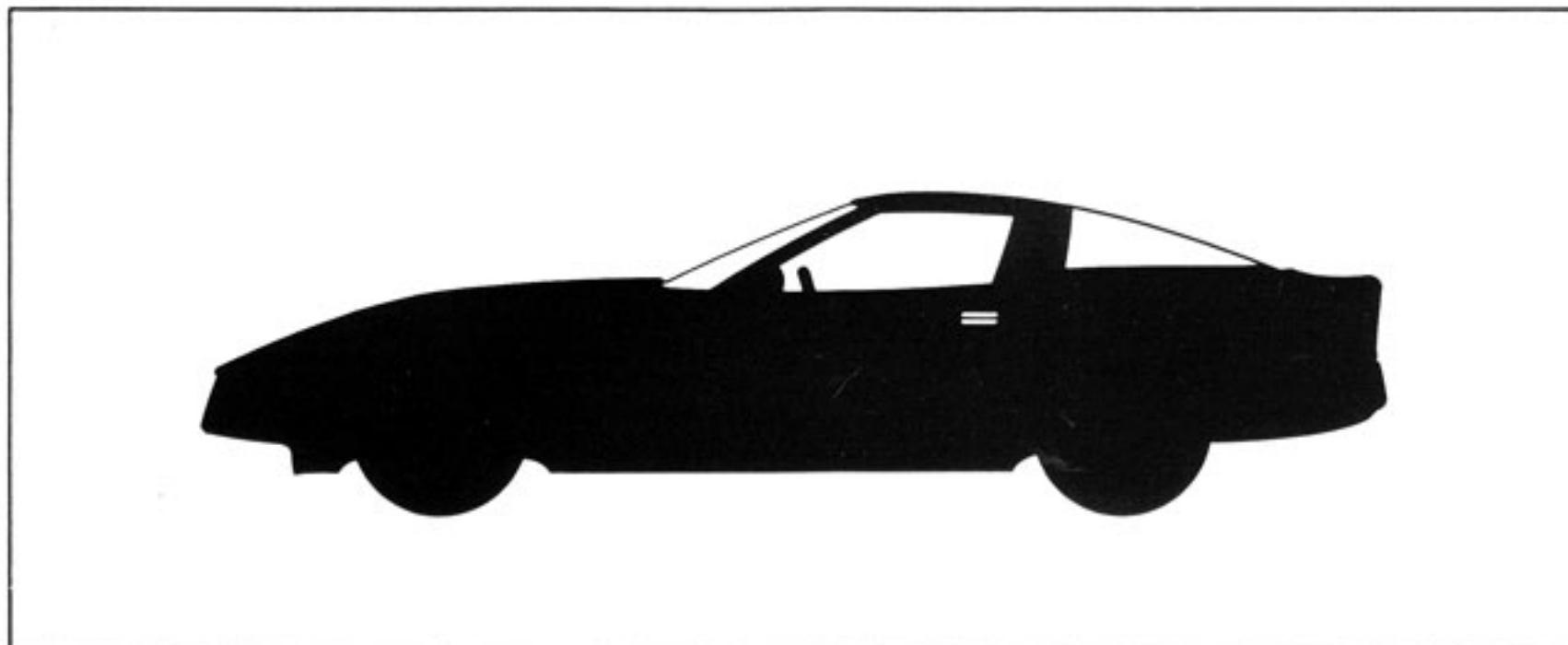

NEW FEATURES

- The first completely new Corvette in over fifteen years!
- Combines the outstanding features of past Corvettes into the sleekest shape in Corvette history.
- Front engine, rear-wheel drive—lighter in weight and trimmer in length.
- New uniframe-design body structure with corrosion-resistant coating.
- Clamshell-opening front end assembly for easy engine access.
- Full-glass rear hatch with three remote releases and roller-shade cargo cover.
- One-piece fiberglass roof panel with special remover.
- Independent front and rear suspension, each with fiberglass transverse leaf spring and forged A-arms.
- Rack-and-pinion steering—power assisted.
- Ultra-contemporary instrument panel features electronic liquid-crystal instrumentation with multi-colored analog and digital display in either English or Metric readout.
- Numeric readout of engine and electrical conditions.
- Driver information system with instant MPG, average MPG and range readouts.
- Electronically tuned, seek-and-scan AM/FM stereo with digital clock and 4-speaker system.
- Side-window defoggers, halogen fog lamps and rear corner backup lamps.
- Electrically adjusted outside mirrors and automatic power antenna.
- Cloth seats with lateral support and back-angle adjustments plus wool-pad comfort liner.
- Full-leather bucket seats available.
- Cast alloy road wheels and Goodyear Eagle GT steel-belted radial tires.
- Improved performance.
- Now available: Ultra-high performance Delco Bose sound system.

CONTINUED FEATURES

- Power steering and power four-wheel disc brakes.

- Air conditioning and power windows.
- Anti-theft alarm system with starter-interrupt feature.
- Power-operated, retractable halogen headlamps.
- Full instrumentation with trip odometer and tachometer.
- Computer Command Control.
- 5.7 Liter CFI V8 engine (Cross-Fire Injection).
- Automatic transmission with overdrive fourth gear.
- Aluminum intake manifold with tuned runners.
- Stainless steel exhaust manifolds and free-flow mufflers.
- Hydraulic valve lifters and exhaust valve rotators.
- Magnesium valve rocker covers and air cleaner cover.
- Cold-air induction system.
- Electric in-tank twin turbine fuel pump.
- High Energy Ignition system.
- Second-generation Freedom Plus II battery with sealed side terminals.
- Delcotron generator with built-in solid-state regulator.
- Side-lift jack.
- Front cornering lamps and underhood lamp.
- Automatic speed control available.
- Power door locks available.
- Soft-padded and carpeted door panels.
- Rear window defogger available.
- Headlamp-on reminder.
- Leather-wrapped steering wheel.
- Tilt-Telescopic steering wheel & column.
- Glove compartment lock and lamp.
- Intermittent windshield wipers.
- Cigarette lighter and ashtray.
- Center console with shifter, coin tray, window, radio, air conditioning and outside sport mirror controls.
- Day/night rearview mirror.
- Deep-twist floor and stowage area carpet.
- Acoustical insulation package.

Refer to Dealer Order Guide for option availability and application.

1984 CORVETTE INTERIORS

CORVETTE Standard Interior



CLOTH



		
Graphite	Gray	Blue
		
	Bronze	Saddle

LEATHER (Optional)

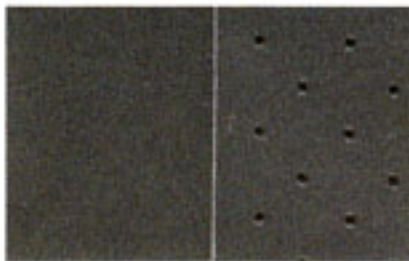

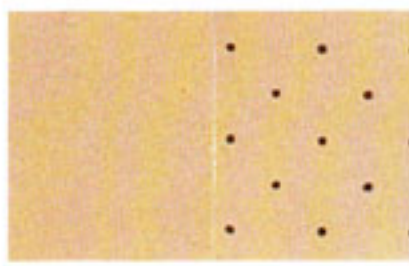
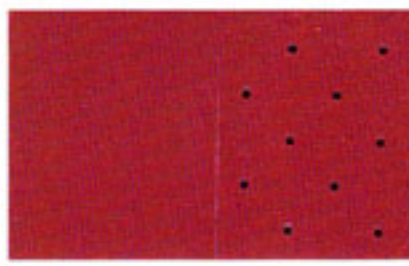



		
Graphite	Gray	Bronze
		
	Saddle	Dark Red

CORVETTE Special Optional Seat* Interior

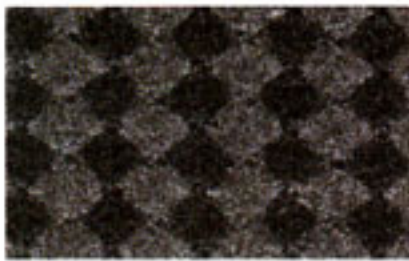
CLOTH

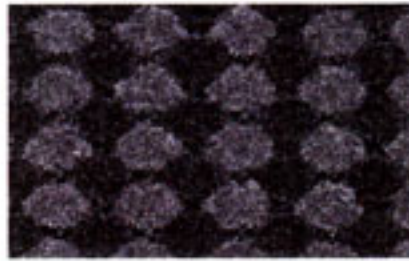

		
Graphite	Gray	Blue
		
	Bronze	Saddle

*Interim availability. Includes driver- and passenger-side power adjustment for lateral and lumbar support, plus back angle. Manual thigh support. Wool-pad comfort liner included with all standard and optional seats.

Refer to Dealer Order Guide for option availability and application.

Exterior Colors

10 – White



16 – Silver (Metallic)



18 – Gray (Metallic)



19 – Black



20 – Light Blue (Metallic)



23 – Medium Blue (Metallic)



53 – Gold (Metallic)



63 – Light Bronze (Metallic)



66 – Dark Bronze (Metallic)



70 – Red

Custom Two-Tone (RPO D84)



Silver (Metallic)/
Gray (Metallic) Accent



Light Blue (Metallic)/
Medium Blue (Metallic) Accent



Light Bronze (Metallic)/
Dark Bronze (Metallic) Accent

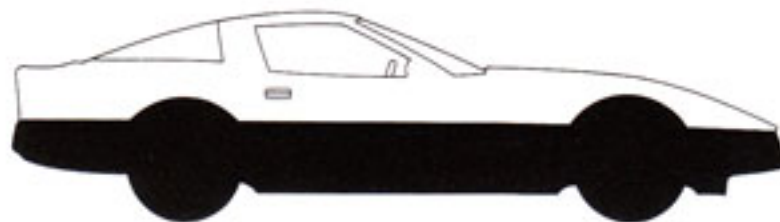

Refer to Dealer Order Guide for option availability and application.

Wheel Trim



Standard 15" cast aluminum wheels with 7"-wide rims in front; 7½" in rear. P215/65R-15 Eagle GT blackwall tires.



Available 16" cast aluminum wheels with 8½"-wide rims and P255/50VR-16 Eagle GT blackwall tires. With Performance Handling Package (RPO Z51), front wheels are 8½"-wide; 9½"-wide in rear and have same P255/50VR16 Eagle GT blackwall tires.

Steering Wheel



Standard black, leather-wrapped rim and spokes with leather-trimmed, padded horn button. Corvette emblem in horn button.

All illustrations and specifications in this brochure are based on the latest product information available at the time of publication approval. Right is reserved to make changes at any time, without notice, in colors, materials, specifications and models, and also to discontinue models. Chevrolet Motor Division, General Motors Corporation, Warren, Michigan 48090.

Chevrolet

Litho in U.S.A. 4270 11/82

Refer to Dealer Order Guide for option availability and application.