

# CHEVROLET



1947 Chevrolet. Stylemaster four-door sedan, 6-cyl

**1947**

# CHEVROLET 1947 SPECIFICATIONS

ISSUED TO

---

---

ORIGINAL COPY

Prepared  
by  
**CHEVROLET—CENTRAL OFFICE**  
**ENGINEERING DEPARTMENT**  
Division of General Motors Corporation  
Warren, Michigan

Manufactured in U. S. A.

## CONTENTS

GENERAL		TRUCK SPECIFICATIONS	
Introduction -----	3-4	Identification Symbols -----	51
Abbreviations and Symbols -----	5	Regular Production Options -----	52-54
<small>10/2003</small>		Accessories -----	55
 <b>PASSENGER CAR SPECIFICATIONS</b> 			
Identification Symbols -----	7	Exterior Colors and Finishes -----	56-57
Regular Production Options -----	8	Serial Numbers -----	58
Accessories -----	9-10	Vehicle Weights -----	59-60
Exterior Colors and Finishes -----	11-12	Equipment Weights -----	61
Serial Numbers -----	13	Chassis Dimensions -----	62-66
Vehicle Weights -----	14	Chassis Treads and Overall Widths -----	67
Exterior Dimensions -----	15	Cowl, Cab, Seat Dimensions -----	68
Body Dimensions -----	16-20	Body Dimensions -----	69-75
Bumpers, Sheet Metal, Body -----	21	Frame -----	76
Body Features -----	22-28	Front Axle -----	77
Frame -----	29	Front Suspension -----	78
Front Suspension -----	29-30	Rear Axle -----	79
Rear Suspension -----	31	Two-Speed Rear Axle -----	80
Rear Axle and Drive -----	32	Rear Suspension -----	81
Drive System Splines, Brakes -----	33	Universal Joints and Propeller Shafts -----	82
Engine: -----	34-41	Drive System Splines -----	83-84
Power Plant General Information -----	34	Brakes -----	85
Engine Performance -----	35	Engine: -----	86-96
Cylinder and Case and Head -----	36	Power Plant General Information -----	86
Crankshaft and Bearings -----	36	Engine Performance -----	87-89
Camsaft and Bearings -----	36	Cylinder and Case and Head -----	90
Piston-Pin-Rings -----	37	Crankshaft and Bearings -----	90
Connecting Rods -----	37	Camsaft and Bearings -----	90
Valve Train -----	38	Piston-Pin-Rings -----	91
Engine Lubrication System -----	39	Connecting Rods -----	91
Fuel and Exhaust Systems -----	39	Valve Train -----	92
Engine Cooling System -----	40	Engine Cooling System -----	93
Engine Electrical System -----	40-41	Fuel System -----	93-94
Clutch -----	42	Exhaust System -----	94
Transmission -----	43	Engine Lubrication System -----	94
Steering, Wheels, Tires -----	44	Engine Electrical System -----	95-96
Lights, Horns, Tools -----	45	Power Plant Mounting -----	96
Page numbers assigned for future additional information -----	46-49	Clutch -----	97
		Transmission -----	98
		Steering -----	99
		Tire Equipment and GVW -----	100
		Wheels -----	101
		Bumpers, Lights, Horn -----	102
		Instruments, Speedometer Gears, Tools -----	103
		INDEX -----	104-105

## INTRODUCTION

### AUTOMOBILE SPECIFICATIONS

In the automobile industry, a specification is defined as any item in a detailed description of a mechanism. Usually the description is composed of separate specifications arranged in a tabular question and answer form.

Specifications of this nature, however, are not required in the manufacture of an automobile. All the information necessary for this process is given by the Engineering Department to the manufacturing and assembling plants in the form of drawings and parts lists. But drawings and parts lists usually are not made available to other people who require information of the vehicle, since these records must be interpreted. Moreover, they and other engineering records are much too numerous or voluminous for convenient reference. Therefore, a special interpretation is made by the Engineering Department in the form of a specifications list or book, the contents of which are determined by the nature of questions people ask the Engineering Department concerning the vehicle.

As has been the experience of most manufacturers, originally the questions asked were few in number and were answered individually at the time they were asked. Through the years, however, many questions were asked quite frequently and, for convenience, the answers were recorded in the form of specifications. Others, which arose because of heightened interest and because of advancements in design were added from time to time. As the automobile grew into a necessary means of transportation - - as its component units were advanced in design and as new ones were added - - and as manufacturers were forced to make more detailed comparisons of their vehicles with those of their competitors to satisfy an increasingly technically minded public - - more and more questions concerning the characteristics of vehicles were answered in the form of specifications.

### THE PURPOSE OF CHEVROLET SPECIFICATIONS

The Chevrolet Engineering Department has always been willing to answer questions of a technical nature concerning Chevrolet products and for the past twenty-six years has endeavored to anticipate such questions by preparing a specifications book each new model year.

This current book has been prepared to answer all the questions concerning the Chevrolet 1947 products that we believe may be asked.

It is intended primarily as a convenient and authoritative source of information for Chevrolet executives, engineers, sales and service representatives, plant managers, and other personnel who must be in a position to answer such questions, and also as a common source of those Chevrolet specifications that are needed in advertisements, vehicle comparisons, trade publications, license applications, and in correspondence with governments, firms, educational institutions, and individuals throughout the world who require a wide variety of information about Chevrolet products for diverse purposes.

### VEHICLES AND EQUIPMENT SPECIFIED

The specifications are those of all standard left drive passenger cars, delivery cars, trucks, and school bus chassis which have been designed to be manufactured for the domestic (U.S.A.) open market. Included also are the specifications of the RPO (Regular Production Option) units which are intended for use with these vehicles. Except where noted all data are for vehicles with regular equipment. RPO units are labeled RPO, and numbered.

No information is furnished concerning right drive vehicles or equipment manufactured for export, nor any vehicles or equipment built on COPO's (Central Office Production Orders) or any other special orders. Accessories released through the Parts and Accessories Department, however, are

## INTRODUCTION—Continued

listed although specifications of these are not included.

As in 1946, this book is separated into two parts -- one for passenger cars and one for trucks.

Except where noted, all information was derived directly from official Chevrolet Engineering Department drawings, parts lists, and test reports, or was calculated from these records.

### ABBREVIATIONS

The condensed tabular form in which the data are presented necessitates the use of abbreviations or symbols in some cases. These are shown on a separate page.

### DIMENSIONS

The dimensions shown are of three types:

Type #1. Those dimensions where very accurate fits are essential in the parts concerned, such as bearing surfaces and splines, and where dimensions usually are expressed on drawings in decimals with very close limits.

Type #2. Those dimensions where accuracy of fit is of less importance, as in structural members such as frame parts, I-beam axles, or in fuel tanks, where dimensions are expressed in fractions or integers with fractions and to which fairly large tolerances ( $\pm 1/64$ ,  $\pm 1/32$ ,  $\pm 1/16$ ) are applied.

Type #3. Those dimensions, such as wheelbases, ground clearances, body size dimensions, and turning diameters, which are subject to large manufacturing variations.

In this book, the dimensions of type #1 are quoted with limits exactly as on the drawings while the dimensions of types #2 and #3 are quoted without manufacturing tolerances.

Unless specified otherwise all dimensions are in inches.

### ORGANIZATION OF BOOK

Every effort has been made to facilitate the finding of information. The sequence followed in presenting the information is that of the G. M. Uniform Parts Classification major groups, modified to facilitate usage by the reading majority, who are unacquainted with this classification. The table of contents lists the subjects in the order in which they occur. The subject headings are reprinted at the bottom of each page beside the page number. The index at the rear of the book lists the details covered by the subject headings.

To provide for reorganizing or incorporating additional information without disturbing the page number sequence, blocks of numbers are assigned to the ends of the passenger and truck sections.

krmh2003

### REVISIONS

All revisions and the dates on which they are made will be indicated at the bottom of the page on which they occur. Where it is necessary to indicate a change in an individual specification, a symbol will be placed in the proximity of the revised specification. This symbol also will be repeated at the bottom of the page with a description of the revision. The following symbols have been established for this purpose:  $\alpha$ ,  $\beta$ ,  $\gamma$ ,  $\delta$ ,  $\epsilon$ . They may be used singly, in multiples, or in combinations.

Subsequent revisions on a revised page will be made in the same manner as described above. However, to emphasize and clarify the later changes, all symbols and descriptions pertaining to previous revisions will be removed from the page and a note including the previous date of change and the word "Revisions" will be added in the space for revision descriptions.

Address all inquiries to: Technical Data Department  
Room 3-111, General Motors Building  
Detroit 2, Michigan  
or call

TR. 2-4600, Extension B127

**ABBREVIATIONS**

AC ----- A. C. Spark Plug  
 Acc. ----- Accessory  
 accel. ----- accelerator  
 adj. (adjust.) ----- adjustment  
 adv. ----- advertised  
 amp. ----- ampere  
 approx. ----- approximately  
 Av. ----- Average

B. (Bak.) ----- Baking  
 Bar. ----- Barometric  
 BC ----- Bottom Center  
 Br. ----- Brown  
 brg. ----- bearing  
 BTC ----- Before Top Center  
 Bus. ----- Business  
 Bush. ----- Bushing

Cab. ----- Cabriolet  
 carb. ----- carburetor  
 cc. ----- cubic centimeter  
 chamf. ----- chamfer  
 Chev. (Ch.) ----- Chevrolet  
 COE ----- Cab-Over-Engine  
 COPO ----- Central Office Production Order  
 comp't. ----- compartment  
 c.p. ----- candle power  
 Cpe. ----- Coupe  
 cu. ----- cubed, cubic  
 cyl. ----- cylinder

Del. (Deliv.)(Dely.) -- Delivery  
 dia. ----- diameter  
 diff. ----- differential  
 Displ. ----- displacement  
 D.R. ----- Double Row  
 dr. ----- door  
 Dul. ----- Dulux  
 DW ----- Dual Wheel

Econ. ----- Economy  
 eff. (effect.) ----- effective  
 Elec. ----- Electric  
 eng. ----- engine  
 equip. (eq.) ----- equipment  
 ext. ----- exterior

F. ----- Fahrenheit  
 fr. ----- front  
 ft. ----- foot  
 ft. lb. ----- foot pound  
 F.U. ----- Fleet Users

gal. ----- gallon

**ABBREVIATIONS AND SYMBOLS**

gen. ----- generator  
 GMC ----- General Motors Corporation  
 GM ----- General Motors  
 gov. ----- governor  
 gr. ----- grain  
 GVW ----- Gross Vehicle Weight

Hg. ----- Mercury  
 hl. ----- high  
 hor. ----- horizontal  
 h.p. ----- horsepower  
 H.R. ----- Hot Rolled  
 hr. ----- hour  
 Hy. ----- Hyatt

I.D. ----- inside diameter  
 in. ----- inch  
 inst. ----- instrument  
 Iv. ----- Ivory

lam. ----- laminated  
 lb. ----- pound  
 L-O-F ----- Libby-Owens-Ford

Map. ----- Maple  
 Mar. ----- Maroon  
 matl. ----- material  
 max. ----- maximum  
 Met. ----- Metallic  
 min. ----- minute, minimum  
 mm. ----- millimeter  
 MPH ----- miles per hour

N.D. ----- New Departure

O.D. ----- outside diameter  
 Ox. ----- Oxford  
 oz. ----- ounce

P. ----- page  
 Pass. ----- Passenger  
 P.D. ----- Pitch Diameter  
 Pick. ----- Pickup  
 pol. ----- polished  
 pr ----- ply rating  
 prop. ----- propeller  
 PSI ----- pounds per square inch  
 pts. ----- pints

qt. ----- quart  
 qtr. ----- quarter

R.C.A. ----- Radio Corporation of America  
 red. ----- reduction  
 reg. ----- regular

retain. ----- retaining  
 Rev. ----- Revolutions  
 RPM ----- revolutions per minute  
 RPO -- Regular Production Option  
 rr. ----- rear

SAE ----- Society of Automotive Engineers  
 Sag. ----- Saginaw  
 Sed. ----- Sedan  
 Serv. ----- Service  
 SFE -- Society of Fine Engineers  
 Ship. ----- Shipping  
 S.L.A. ----- short and long arm  
 spec. ----- special  
 specs. ----- specifications  
 st. ----- stainless  
 stl. ----- steel  
 Strip. ----- Striping  
 St.Wagon (Stn.) -- Station Wagon  
 sq. ----- square  
 S.R. ----- Single Row

TC ----- Top Center  
 thd. ----- thread  
 trans. ----- transmission

U-joint ----- Universal joint  
 Univ. -- universal, universally  
 univ. mtg. -- universal mounting  
 up. (uphol.) ----- upholstery  
 vent. ----- ventipane









w/ ----- with  
 W.B. ----- wheelbase  
 whl. ----- wheel  
 W/S (Windsh'd) ----- windshield

**SYMBOLS**

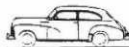
# ----- pound, number  
 + ----- plus  
 - ----- minus  
 & ----- and  
 x ----- times  
 : ----- to (ratio)  
 ----- to (range)  
 / ----- per  
 % ----- per cent  
 & ----- centerline  
 ° ----- degree  
 ' ----- minute  
 " ----- second; inch  
 ÷ ----- divided by

**PASSENGER  
CARS**

**IDENTIFICATION SYMBOLS**

VEHICLE TYPE	NAME AND DESCRIPTION	ENGINEERING SYMBOL		
		SERIES 2000 (EK)		1500 (EJ)
		FLEETLINE	FLEETMASTER	STYLEMASTER
	<b>SPORTMASTER SEDAN</b> 6-passenger, 4-door, 5-window sedan with built-in trunk.	2113 47-1069*		
	<b>AEROSEDAN</b> 5-passenger, 2-door, 5-window, plain-back coach with luggage compartment in rear.	2144 47-1007*		
	<b>SPORT SEDAN</b> 6-passenger, 4-door, 7-window sedan with built-in trunk.		2103 47-1019*	1503 47-1219*
	<b>TOWN SEDAN</b> 6-passenger, 2-door, 5-window coach with built-in trunk.		2102 47-1011*	1502 47-1211*
	<b>SPORT COUPE</b> 6-passenger, 2-door, 5-window coupe with luggage compartment in rear deck.		2124 47-1027*	1524 47-1227*
	<b>BUSINESS COUPE</b> 5-passenger, 2-door, 5-window coupe with luggage compartments behind seat and in rear deck.			1504 47-1227B*
	<b>CABRIOLET</b> 5-passenger, 2-door, 5-window, folding top coupe with luggage compartment in rear deck.		2134 47-1067*	
	<b>STATION WAGON</b> 6-passenger, 4-door, 7-window, wooden body with drop and lift gates in rear.		2109 47-1062*	
	<b>SPECIAL DELIVERY</b> 2-passenger, 3-door, 3-window, panel delivery car.			1508 47-1271*
	<b>CHASSIS</b> Chassis, cowl and Fleetmaster wind- shield, Fleetline instrument panel (less cigarette lighter). Items ship- ped loose: Wheelhouse panels, tail and stop lamps, license lamp and bracket, door window ventilators, sunshade panel, door arm rest frames and trim retainers, and rear name plate.			1501

\*-Fisher Body style number.



**REGULAR PRODUCTION OPTIONS**

Definition: Items released by the Engineering Department for installation at the assembly plant at the customer's request, in addition to or in place of regular equipment, and usually at extra cost.

GROUP REFERENCE	ITEM		RPO NUMBERS AND REMARKS		
Exterior colors and finishes	Hood, body and wheel paint		Station Wagon: 235K	Cabriolet: 235A-235C 235D-235K	All Others: 235A 235B-235C-235D-235E 235F-235G-235H-235J
Seats	Upholstery	Ten Bedford Cord (when available)	Fleetmaster: Town Sedan - 355D Sport Sedan - 355G Sport Coupe - 355H		
		Top and seat material trim and color combination	Cabriolet: 377A-377B-377C-377D 378A-378B-378C-378D 378E	Station Wagon: 352A-352B-352C	
	Taxicab type cushion springs		Stylemaster: Town Sedan - 266E Sport Sedan - 266C Sport Coupe & Business Coupe-266A	Fleetmaster: Town Sedan - 266D Sport Sedan - 266B Sport Coupe - 266A	
	Taxicab cloth trim		Fleetline: Sportmaster Sedan - 266F 331A (use with RPO 330)		
	Taxicab imitation leather trim		332A (use with RPO 330)		
Side doors	Right hand rear door lock remote control		Stylemaster & Fleetmaster Sport Sedans - 225A 229F - (2 shelf package racks)		
Sedan Delivery equipment	Back of seat screen and partition, rear window screen, inside rear door handle, package racks.		229D - (single shelf parcel racks)		
	Partition & rr. door screens, inside handle		229G - (RPO 229D plus inside ladder racks) 229E		
Suspension	Heavier rear springs		Chassis and sedans - 254A All coupes - 254B		
Engine	Economy engine conversion equipment		224A		
	Governor	With air cleaners 216A, P or G	241A (use with RPO 260B or 260D)		
	Carb. to accel.rod	With reg. eng. and governor 241A	260B		
	Economy eng. equipment (half throttle)	and gov. 241A no governor	260D 260A		
	Oil filter		237A (not used on Cabriolet)		
	Air cleaners	Truck Oil bath	216A with or without governor 2160 with governor; 216C without governor 216F with governor		
	1 lb. dirt capacity				
	2 lb. dirt capacity				
	Radiator overflow return tank		271A		
	Clutch	Heavy duty		227A	
Transmission	Heavy duty with 4.11 axle		316A		
	Heavy duty with 3.73 axle		316B		
Rear axle	3.73:1 ratio		201A w/reg. trans.; 201B w/heavy duty trans.		
Tires	6.00-16-6 ply (five)		274E		
	6.00-16-4 ply (five)-White wall one side		284A		
Lights	Tail and stop lamps	Dual: Single L.H. Single R.H.	Sedan Delivery: 249A ☐ Sedan Delivery: 249B Station Wagon: 249C ☐		
	Taxicab equipment-Stylemaster Sport Sedan	4.11 axle and reg. front springs		330A (use with RPO 331A or 332A) ☐	
3.73 axle and reg. front springs		330B (use with RPO 331A or 332A) ☐			
4.11 axle and heavy duty front springs		330C (use with RPO 331A or 332A) ☐			
	3.73 axle and heavy duty front springs		330D (use with RPO 331A or 332A) ☐		

☐ - For State of Washington

☐ - Also includes changes in fan blade assembly, clutch, transmission, and body side guards in place of body sill moldings.

**ACCESSORIES**

Definition: Items made available at extra cost through the Parts and Accessories Department and installed by the customer or his dealer. Engineering Service numbers are shown in parentheses in the table below.

ITEM		PART NUMBER						
Antenna	Cowl-type	985995 (609697)						
Arm rest	Door, for 1500 series	985793 (606673)						
Ash tray	For 1500 series	986105 (3684345)						
Cap	Gas tank, locking	985076 (602767) or 986166						
Clock	Electric	986096 (5073960) or 986068 (3847023)						
	Hand wind, for 1500 series	986100 (3847090)						
Compass	Auto	986131 (3847317)						
Connection	Spare tire air	985480 (603650)						
	Tire air transfer	986134 (3847315)						
Cover	Radiator	986115 (3847184)						
	Rear fender wheel, Fleetline	985874 (609520)						
	Rear fender wheel, exc. Fleetline	985873 (606368)						
Cover, seat	Type and Color		4 dr Sedans	Aerosedan	2 dr Sedans	Bus. Coupe	Spt. Coupe	
	Standard	Front and rear	986010	986011	986009		986012	
			986157	986158	986156		986159	
			985813	985814	985812		985818	
	Deluxe	Gray Plaid #2 Highland #3 Blue Gray	Fr. & Rr.	986138	986139	986137		986140
								985832
985890				985891	985889		985895	
Cushion	Back rest	985847						
Deflector	Rail, side window, sets	985782		985781		985783		
	Door window, draft	986149 (3847472)						
Defroster	For dash heater	986132 (3119145) or 986064 (3119187)						
	For underseat heater	986066 (3119175) or 986125 (3119674)						
	Rubber blade fan	986111 (3847138)						
	Windshield electric heater	601168						
Dispenser	Tissue	985858						
Extension	Muffler tail pipe	985992 (609529)						
Filter	Gasoline	986118 (3847195) or 986128 (3847214)						
Frame	License plate	985849 (606409)						
Governor	Regular engine	985965 (609359)						
Guard	Fender, front, pair	985977 (609497)						
	Fender, rear, pair	985978 (609498)						
	Gravel, rear fender	986001 (609589)						
	Trunk	985979 (609480)						
Heater	Deluxe, dash	986061 (3119160) or 986101 (3119143)						
	Underseat	986063 (3119151)						
	Super deluxe, dash. & def.	986062 (3119101)						
	Shut off valve	985533						
Holder	Debrells	985929 (607542)						
Injector	Static eliminator	986035						
	Powder for injector	986035						
Jack	Bumper	986008 (609575) or 986177 (3847610)						
	Hydraulic	986141 (3847485)						
Lamp	Back-up	986095 (3847054)						
	Fog, dual	986163 (3847576)						
	Glove compartment	986110						
	Luggage compartment	986106 (3847114)						
	Spot, Unity, without bracket	985993 (609567)						
	Bracket for Unity spot light	985777 (605575)						
	Spot, Guide, without bracket	986055						
	Bracket for Guide spot light	986056 (3847002)						
	Spot, Unity, with bracket	986172 (3847607)						
	Spot, Guide, with bracket	986170 (3847571)						

CONTINUED

**ACCESSORIES - Continued**

	ITEM	PART NUMBER
Lamp	Trouble, magnetic	986174 (3847605)
	Underhood	986112 (3847150)
Lighter	Cigarette, for 1500 series	986050 (3862906)
Lock	Spare tire	985725 (605232)
Mat	Tire traction	986108 (3847142)
Mirror	Cabriolet, R.H.	985776 (605486)
	Clamp-on	982188 or 985954 (609248)
	Non-glare	985994 (917316)
	Rain deflector	986178 (3847621)
	Visor, vanity	985268 (602916)
	Visor, vanity, electric	986663 (606340)
Moulding	Front fender	986002
No-Rol	Device	985681 (604935)
Ornament	Hood	986107 (3847120)
		166705
Plug, magnetic	Rear axle	985287 (602739)
	Oil pan	985293 (603045)
	Transmission	985288 (602745)
Radio	Super deluxe, R.C.A.	985996 (609631)
	Deluxe, Delco	985793 (606628)
	Universal, Colonial	986146 (3847487)
	Speaker, conversion	986147 (3847486)
Ring, wheel	Stainless steel, set of 5	1279601
	Stainless steel, single	1279680
	White, set of 4	986003 (609565)
	White, single	986004 (609666)
Screen	Door ventilator	986135 (3847324)
	Radiator	986097 (3847188)
Seat	Ventilated pad	985086 (603276)
Shield	Rear window, frost	985870 (606339)
	Ventilator, frost (pair)	985529
	Windshield, frost	985702 (605017)
	Rear fender (pair)	986148 (3847590)
Signal	Handbrake	985721 (605136)
	Direction	986006 (609593)
Sunshade	Right hand	985875 (606682)
	Non-glare	986136 (3847327)
Tank	Radiator overflow	985528 (604039)
Thermo-stat	148° - 155°	985127
	166° - 174°	985787
	178° - 185°	986060
Washer	Windshield	986041 (609731)
	Anti-freeze with solvent	986180
Wheel	Deluxe steering	986005 (609574)
Wiper, rear window	Sport Sedan, Town Sedan	985877 (606302)
	Coupe	985881 (606337)
	Sportmaster Sedan	985880 (606336)
	Aerosedan	985882 (606462)





**SERIAL NUMBERS**

**SERIAL NUMBER LOCATIONS**

(See descriptions below.)

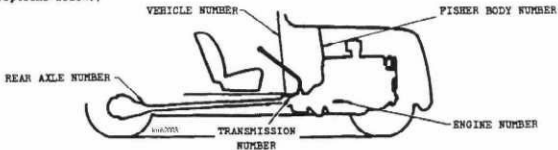

NOTE: Serial numbers were obtained from Standards Department.

**VEHICLE SERIAL NUMBER**

Description ----- Combines symbols for assembly plant, model year, model, and month of manufacture, in that order, followed by serial number for each vehicle. Example: 3 EK-A-2022.

- Assembly plant symbols - Flint, Mich. ----- 1  
 - Tarrytown, N. Y. ----- 2  
 - St. Louis, Mo. ----- 3  
 - Kansas City, Mo. ----- 5  
 - Oakland, Calif. ----- 6  
 - Atlanta, Ga. ----- 8  
 - Norwood, O. ----- 9  
 - Baltimore, Md. ----- 14  
 - Van Nuys, Calif. ----- 20  
 - Janesville, Wis. ----- 21

- Model year designation ----- E  
 Model designation - Stylemaster ----- J  
                     - Fleetmaster and Fleetline - K  
 Calendar month designation - January ----- A  
                                     - February ----- B  
                                     - March, etc. - C, etc.

Starting serial number ----- 1001 and up, at each assembly plant and for each series.  
 Location ----- Stamped on plate on right front door hinge pillar.

**ENGINE SERIAL NUMBER**

Description ---- Combines symbols for each model year, passenger car engine, and manufacturing plant in that order, followed by serial number for each engine. Example: EAA-6375.

Model year designation ----- E  
 Passenger car designation ----- A

Type and plant:	Flint	Tonawanda
-Regular engine	A	F
-RPO 227A with heavy duty clutch	C	F

Starting serial number ---- 1001 and up, at each engine plant.  
 Location ----- Stamped on right side center of engine cylinder block just to rear of distributor.

**TRANSMISSION SERIAL NUMBER**

Description --- Combines symbols for model year, and type and plant, followed by serial number for each transmission. Example: EB-1764.

Model year designation ----- E

Type and plant:	Saginaw	Huncle	Toledo
-Regular with 4.11:1 Axle	A	B	C
-RPO 201A with 3.73:1 Axle	D	E	F
-RPO 316A heavy duty transmission and 4.11:1 Axle	G	H	J
-RPO 316B heavy duty transmission and RPO 201B 3.73:1 Axle	K	L	M

Starting serial number ---- 1001 and up, at each transmission plant.  
 Location -- Stamped on case at front edge of cover.

**REAR AXLE SERIAL NUMBER**

Description --- Combines symbols for model year, and type and plant, followed by number of rear axle. Example: EB-1112.

Model year designation ----- E

Type and plant:	Gear & Axle	Buffalo
-Regular (4.11:1 Axle)	A	B
-RPO [201A or B (3.73:1 Axle) 330A or C (4.11:1 Axle) 330B or D (3.73:1 Axle)]	C	D
	J	F
	L	M

\* - These are Taxicab chassis options. They incorporate brake linings with deeper recesses for rivets.

Serial number --- The first two digits represent the month; the last two, the day of month.

Location ----- Stamped on front, right side of differential carrier.

**BODY NUMBER**

Description --- Consists of separate numbers and symbols for body style, body number, trim type, and paint combination. Controlled by body source.  
 Location ----- Stamped on plate on right side of front of dash.

**VEHICLE WEIGHTS—POUNDS**

VEHICLE TYPE	FLEETLINE		FLEETMASTER		STYLEMASTER	
	Shipping	Curb	Shipping	Curb	Shipping	Curb
Sportmaster Sedan	3150	3280				
On front wheels	1650	1660				
On rear wheels	1500	1620				
Aerobedan	3125	3255				
On front wheels	1650	1660				
On rear wheels	1475	1595				
Sport Sedan			3185	3315	3150	3260
On front wheels			1675	1685	1660	1670
On rear wheels			1510	1630	1470	1590
Town Sedan			3125	3255	3075	3205
On front wheels			1665	1675	1645	1655
On rear wheels			1460	1580	1430	1550
Sport Coupe			3090	3220	3060	3190
On front wheels			1660	1670	1650	1660
On rear wheels			1430	1550	1410	1530
Business Coupe					3050	3180
On front wheels					1650	1660
On rear wheels					1400	1520
Cabriolet			3390	3520		
On front wheels			1770	1780		
On rear wheels			1620	1740		
Station Wagon			3440	3570		
On front wheels			1595	1655		
On rear wheels			1845	1915		
Sedan Delivery					3075*	3205*
On front wheels					1645*	1655*
On rear wheels					1430*	1550*
Chassis					2175*	2305*
On front wheels					1325*	1340*
On rear wheels					850*	965*

\* - Estimated weight.

**VEHICLE WEIGHT CONDITIONS**

**SHIPPING WEIGHT:** This weight is established by the Traffic Department; it is the weight of the basic vehicle with all regular equipment and with grease and oil wherever required. It does not include the weight of gasoline or water.

**CURB WEIGHT:** This is the weight of the empty vehicle ready to drive. It is the shipping weight plus the weight of gasoline (99 pounds) and water (31 pounds).

**PERFORMANCE WEIGHT:** This is the curb weight of the lowest priced 6-passenger, 4-door sedan in each line with regular equipment plus 450 pounds for passengers.

Representative vehicles are:

Fleetline Sportmaster Sedan ----- 3730 pounds  
 Fleetmaster Sport Sedan ----- 3765 pounds  
 Stylemaster Sport Sedan ----- 3710 pounds

**EXTERIOR DIMENSIONS**

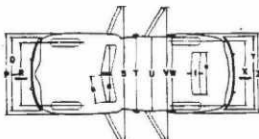
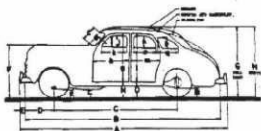

ITEM	Sym- bol	FLEETLINE		FLEETMASTER AND STYLMASTER			FLEETMASTER		STYLMASTER	
		Aero- Sedan	Sport- master	Sport Sedan	Town Sedan	Sport Coupe	Cab- riolet	Station Wagon	Bus, Coupe	Bedan Delivery
Car length	Overall	A		197-3/4				207-1/2	197-3/4	198-1/2
	Less bumpers	B		184-1/16				200-1/8		184-1/16
	Wheelbase	C					116			
	Wheel center to grille front	D					27-7/16			
Maximum car height	Loaded	De	63-5/8	66-1/8	66-7/8	65-5/8	69-7/8	65-7/8	66-7/8	
	No load	Hg	66-7/8	69-3/8	68-5/8	68-3/8	73	67-1/4	69-7/8	
Minimum road clearance	Under front spring seats	KE				8-1/4				
	Under exhaust pipe	LE				7-1/4				
Door step height	Front	Ng				7-7/8				
	Rear	Og		16		15-3/4				
Maximum car width	Over front fenders	F	73-3/8				72-5/8			
	Across front bumper	Q				66-1/8				
Wind- shield	Front wheel tread	R				57-5/8				
	Over front doors, open	S	155-1/2	135-1/4	127	148-1/2	130-1/2	148-1/2	127	
	Over front door handles	T	66-15/16	69-5/16	66-7/8	69-15/16	66-7/8	69-15/16	66-13/16	
	Across body	O				70-7/8 (at sill)				
	Over rear doors, open	V	128	119			124-1/2			
	Over rear door handles	W	70-1/8	69-7/8			70			
	Rear wheel tread	X					60			
Rear window	Across rear bumper	Y		66-1/8			66-3/4		66-1/8	
	Over rear fenders	Z				72-3/4				
	Width between pillars	ba				46-1/4				
	Width to bar	bb				23-1/4				
Front side door	Height & slope from vertical	ca	18-3/8		14-1/2	Slope, 41° (all models)				
	Corner post (on diagonal)	cb				4				
Rear side door	Width	cc		36			23-5/8	50-3/8	36	
	Height	cd	14-7/8	10-3/4		12-1/2	5-5/8	12-1/4	12-1/2	
Front side door	Opening width, maximum	e	48-3/8		45-1/8		43-1/4	48-1/2	45-1/8	
	Opening height, maximum	f	See page 18	See page 18	Page 18	Page 18	See page 19	Page 18	Page 20	
	Window height, maximum	g	11-3/16		12-1/4		14-5/8		12-1/4	
	Window length, maximum	h	27-7/16	27-9/16	25-7/8	35	36-5/16	25-3/4	35	
Rear side door	Opening width, maximum	i	See page 18	43-7/8				49-1/2		
	Opening height, maximum	j	See page 18	18-1/4				15-7/8		
	Window height, maximum	kl	20-3/8	18-1/4				25-1/4		
	Window length, maximum	km	22-1/8	22-1/8				22-9/16		
Rear quarter window	Height, maximum	pn	10-7/16	11-3/4	11-7/8	10-6/8	11-1/2	16-1/8	10-5/8	
	Length, maximum	q	20-1/2	19-1/2	24-15/16	22-9/16	16-7/8	22-1/8	22-9/16	

\* - Under design load conditions, curb height with regular equipment, plus weight of specified number of passengers (150 lb. each), plus trunk load or payload.    \*\* - At shipping weight height.    S - Road clearance is based on static conditions of tires and springs under design load (see w). Actual clearances with car in operation when loaded are greater.    X - Visual stress, measured on surface of glass.







BODY INTERIOR DIMENSIONS—Continued

SPORT COUPE (Stylemaster 1524 and Fleetmaster 2124)

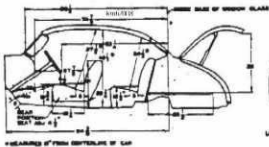
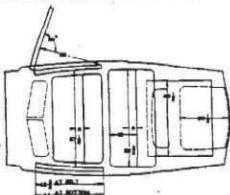

— SHOULDER HEIGHT—SE BELT  
— SEAT HEIGHT

BUSINESS COUPE (Stylemaster 1504)

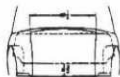
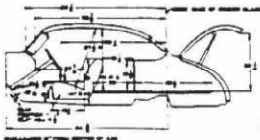
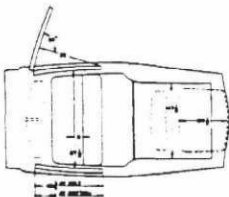

— SHOULDER HEIGHT—SE BELT  
— SEAT HEIGHT

CONTINUED



BODY INTERIOR DIMENSIONS—Continued

SEDAN DELIVERY (Stylemaster 1508)

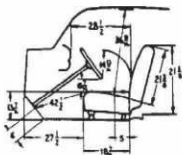
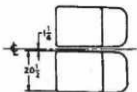

Seat in rear position.  
Adjustment = 4"

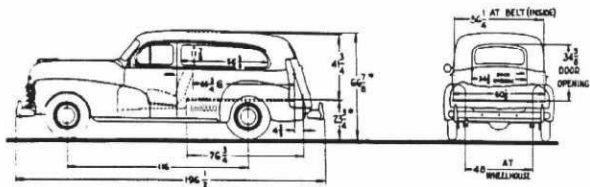

\* - Loaded height with 6.00-16-4 ply tires.

@ - With seat in rear position.

**BUMPERS AND CHASSIS SHEET METAL**

ITEM		FLEETLINE	FLEETMASTER		STYLEMASTER		
		Sportmaster and Aeroedan	Sedans, Coupe and Cabriolet	Station Wagon	Sedans and Coupes	Sedan Delivery	Chassis
Bumpers	Make	Own					
	Type	Front	Full-width, conventional				
	Rear	Full-width, conventional	2 bumpers	Full-width, conventional	Full-width, recessed	Full-width, conventional	
Guards	Two, conventional, both front and rear.						
Splash and gravel deflectors	Front	Extension of radiator splash shield between bumper and radiator grille.					
	Rear	Metal. Between rear of body and rear bumper. Attached to bumper. Slides under body.			Metal. Between rear of body and rear bumper. Attached to bumper. Slides under body.		
	Fender	Black rubber. Attached to leading end of both rear fenders.					
Radiator grille	Plain horizontal bar type. Stamped bars except die cast top bar. Chrome plated.						
Hood	Type	Alligator jaw. Counterbalanced, spring-loaded hinges at rear. Integral sides.					
	Lock control	Remote. Handle at left of steering wheel below instrument panel.					
	Louvers	None					
	Model name	"Fleetline"	"Fleetmaster"	"Stylemaster"			
	Emblem	On plates mounted at rear of hood sides.					
	Ornament	On chrome plated background with horizontal wings.					
Fenders	Top molding	Die cast airfoil shape, chrome plated.					
	Front	Painted hood color.					
	Rear	Deep crowned, full-skirted, "Donor-Action" type with shallow "cat-walk".					
Front sheet metal mounting	Valance moldings	3, fr. & rr. Pol. st. stl.					
	Sound deadener	Asphalt base compound sprayed on wheelhouses					
	Front sheet metal mounting	"Stabilized." Fenders, headlamps, and radiator mounted as a unit on central rubber cushion.					
	License plate location	Front	On bumper center.				
Sheet metal finish	Rear	At center of trunk door above handle and license lamp cluster.	Below lamp at left top of tail gate.	Same as Fleetmaster.	On rear door center above tail lamp.	(Brackets shipped loose)	
	Bonderized, primed, and lacquered with Dupont pyroxylin lacquers.						

**BODY GENERAL INFORMATION**

ITEM	FLEETLINE AND FLEETMASTER			STYLEMASTER	
	Sedans and Coupe	Cabriolet	Station Wagon	Sedans, Coupes, Sedan Delivery	Chassis
Make	Fisher Body Division, GMC				
Body shell construction	Unisteel. All steel parts. Turret-Top, cowl, side, and rear panels, and underbody thoroughly braced by box-section reinforcements and welded into one solid unit. Double-walled doors. All-steel seat frames. Reinforced by Box-girder chassis frame. Thorough insulation.	Same as Coupe except for fabric top. Reinforced by special VI-braced Box-girder chassis frame.	All steel cowl and underbody. Hardwood body and door frames. Mahogany panels. Slat and vinylite top. Regular chassis frame.	Same as Fleetmaster Sedans and Coupe.	All steel cowl and underbody.
Exterior finish	Bonderized, primed, and lacquered with Dupont pyroxylin lacquers.		Clear air dry Dulux.		Bonderized and primed.
Ventilation	Fisher "No-Draft" ventilation.				

**WINDSHIELD AND RELATED EQUIPMENT**

ITEM	FLEETLINE		FLEETMASTER		STYLEMASTER		
	Sportmaster and Aeroedan	Sedans and Coupe	Sedans and Cabriolet	Station Wagon	Sedans and Coupes	Sedan Delivery	Chassis
Glass Description	Two flat panes divided by vertical bar in permanent "Windstream V" installation.						
Material	L-C-P Hi-Test Safety (laminated) Plate. (See p. 15 for size.)						
Outside molding	Polished stainless steel				Black rubber		Pol. st. etc.
Divider bar finish	Polished stainless steel						
Outside	Golden Walnut Grain						
Inside	Golden Walnut Grain						
Garnish molding	Two. Formed in garnish molding below center of each pane of glass.						
Defroster slots	Two, vacuum operated. Ivory plastic control on top of instrument panel.						
Wipers	Blades park flush with windshield lower molding and point toward divider bar.						
Rear view mirror	Rectangular, adjustable; inside at top of divider bar.	Circular, adjustable; outside, on left door.	Rectangular, adjustable; inside at top of divider bar.	Circular, adjustable; outside on left door.			
Sunshades	2, universally adjustable sliding type.	2, hinged at both ends.	2, universally adjustable sliding type.	1, for driver. Same as in Fleetmaster Sedans and Coupe.	1, universally adjustable sliding type for driver.	2, same as in Fleetmaster Sedans and Coupe, less trim.	

**INSTRUMENT PANEL AND INSTRUMENTS**

ITEM	FLEETLINE Sportmaster and Aeroedan, STYLEMASTER Chassis.	FLEETMASTER	STYLEMASTER (except chassis)
Base panel finish	Golden Walnut Grain	"Two-tone". Crown, Golden Walnut Grain; face, Metallic Brown.	Brown Metallic Duco
Ornamentation	Continuous effect; chrome plated bars extend below instrument cluster and across glove compartment door from satin finished chrome radio grille. Upper and lower bars of radio grille of polished chrome with red and blue trademark on upper bar and CHEVROLET name in black on lower bar. Plastic control panel below radio grille, speedometer and clock bezels are honey beige color.		Styling similar to Fleetline and Fleetmaster except no polished chrome bars below instrument cluster or on glove compartment door. Yellow stripes around center chrome plated disc decorate clock cover plate.
Instruments	AC electric fuel gauge, electric battery charge and discharge indicator, pressure heat indicator, and pressure oil pressure gauge grouped in one assembly in instrument panel directly ahead of driver. AC, large dial, "Safety-Guide" speedometer (driven by flexible shaft), with odometer and headlamp beam indicator, in line with steering column.		
Clock	Stem wind, 39-hour, illuminated type of various makes.		None. Plate covers opening.
Control knobs	Throttle, choke, and hood opening control knobs, ivory plastic with copper-toned inserts. Windshield wiper control knob, ivory plastic. Cowl ventilator control knob, brown plastic.		Cowl ventilator control knob, brown plastic. All others on instrument panel are ivory plastic.
Cigarette lighter	Electric. Chrome plated. Various makes. On control panel below clock.		None. Bright metal disc covers opening in control panel.
Radio provision	Speaker grille in center of instrument panel. Control cover plate directly below.		
Glove compartment	At right of instrument panel. Has automatic light and key lock.		At right of instrument panel. Has key lock, but no light.
Ash receiver	In instrument panel crown. Has sliding cover.		None. Plate covers opening.
Cowl ventilator	Screened 3" x 15" (approx.) opening. Cover opened by positive leverage. Handle directly below instrument panel.		

## FRONT SEAT AND RELATED EQUIPMENT

ITEM	FLEETLINE		FLEETMASTER				STYLMASTER				
	Aero-sedan	Sport-master	Sport Sedan	Town Sedan, Coupe	Cabriolet	Station Wagon	Sport Sedan	Town Sedan, Coupes	Sedan Delivery	Chassis	
Seat and back type	Full-width; split back.	Full-width; full back.	Full-width; split back.	Full-width; split back.	Full-width; split back.	Full-width; full back.	Full-width; split back.	Two separate bucket seats.			
Upholstery	See UPHOLSTERY MATERIALS, page 24.										
Seat Cushion	Plain, with French seam at ends.			1 horizontal piped bead	2 vertical stitched beads. Lateral seam at ends.	Plain, with French seam at ends.		Plain			
Back	Plain, with French seam around outside edge.	13 pleats in center. Plain ends.	5 pleats in center. Plain ends.	1 horizontal seam.	1 horizontal over 2 vertical stitched beads.	Plain, with 1/8 x 1/4 central risers.	Plain, with French seam on outside edges of each half.	Plain			
Scuff pads	See UPHOLSTERY MATERIALS, page 24										
Arm rests	2, of door-pull type. Also see UPHOLSTERY MATERIALS, page 24.										
Adjustment	4-1/2" in 8 positions by chrome plated lever at left side of seat riser. Seat rises and tilts as it moves forward.								4"		0
Floor mat	Brown rubber with carpet inserts				Brown rubber		Black rubber				

\* - Two arm rest frames and trim retainers only, shipped loose.

## REAR SEAT AND RELATED EQUIPMENT

ITEM	FLEETLINE		FLEETMASTER				STYLMASTER			Bus. Cpe.	
	Aero-sedan	Sport-master	Sport Sedan	Town Sedan	Sport Coupe	Cabriolet	Station Wagon	Sport Sedan	Town Sedan		Sport Coupe
Seat and back type	Full-width		Full-width				Rear, Full; center, 2 pass.	Full-width			
Upholstery	See UPHOLSTERY MATERIALS, page 24.										
Seat Cushion	Plain, with French seam in center.	Plain, with French seamed ends.	Plain, with French seam and at ends.	Plain, with French seam in center.	Plain, with 1 horizontal piped bead.	2 vertical stitched beads. Lateral seam at ends.	Plain, with French seam in center and at ends.	Plain, with French seam in center.			
Back	Plain	Plain. French seamed edge.	14 vertical pleats in center; plain ends.	Plain.	1 horizontal seam.	Plain head rest. 2 vertical beads on back rest.	Plain, with three 1/8 x 1/4 risers in center.	Plain			
Scuff pads	See UPHOLSTERY MATERIALS, page 24.										
Arm rests	2. See UPHOLSTERY MATERIALS, page 24.										
Roof cords (flexible)	2	1	2				1, on back of front seat.				
Ash receiver	In each arm rest	1, in back of front seat.		In each arm rest		In each side wall					
Assist straps	2, fixed	2, retractable, with coat hooks.		2, fixed							
Coat hooks	2										
Foot rest	Recessed in front seat back						Recessed in fr. seat back				
Carpet	High quality carpet						Brown Linoleum		Good quality carpet		
Parcel shelf	Full-width. Below and ahead of rear window.						Full-width. Below and ahead of rear window.				



**UPHOLSTERY MATERIALS**

ITEM	FLEETLINE		FLEETMASTER		STYLEMASTER	
	Sportmaster and Aerosedan	Sedans and Coupes	Cabriolet	Station Wagon	Sedans and Coupes	Sedan Delivery
Seat and back cushion (front and rear) upholstery	Tan, color-striped "Fleet-weave," flat-woven fabric. No options.	Light gray, striped, pile fabric. Tan cloth optional. (See RPO 355).	Genuine leather and Bedford Cord, RPO 377.	Tan imit. leather. Tan genuine leather, RPO 352.	Light tan-gray striped pile fabric. No options.	Seats, side door panels and pillars, head lining and sun visor upholstered in blue-black Spanish grain imit. leather.
Front seat back, side wall, and door uphol.	Tan mixture flat-woven fabric	Plain gray pile fabric	Imit. leather matching color of seat leather	Tan imit. leather on backs of all seats	Plain gray pile fabric	Masconite load space side walls and steel inside rear corner and door panels finished in tan enamel.
Head lining	Plain tan cloth to match seat upholstery	Plain gray cloth to match seat upholstery	See "Cabriolet Convertible Top"	Tan imit. leather above windshield	Plain gray cloth to match seat upholstery	
Sun visor upholstery	Head lining cloth with brown Spanish grain imit. leather grip	Head lining cloth with dark gray Spanish grain imit. leather grip	Imit. leather matching color of seat leather	Tan imitation leather	Head lining cloth with brown Spanish grain imit. leather grip	
Seat Plier and door scuff pads	Brown Spanish grain imitation leather.	Dark gray Spanish grain imit. leather.	Included in seat and door upholstery		Brown Spanish grain imit. leather on doors	
Arm rest upholstery. (See seat specs. for other details)	Front	Brown Spanish grain genuine leather top. Bright metal bead. Door upholstery below.	Dark gray Spanish grain genuine leather top. Bright metal bead. Door upholstery below.	Seat-colored Spanish grain genuine leather all over with bright metal bead.	Tan Spanish grain genuine leather top. Bright metal bead. Tan imit. leather below.	
	Rear	Seat upholstery.	Seat upholstery. Dark Spanish grain imit. leather tops on sedans.			Seat upholstery on Sport Coupe and Sedans.

\* - Genuine red leather and tan Bedford Cord with standard Mayland Black paint. Tan, red or blue genuine leather and tan Bedford Cord, RPO 377. Full tan Bedford Cord, RPO 378.

**FRONT DOORS AND RELATED EQUIPMENT**

ITEM	FLEETLINE		FLEETMASTER		STYLEMASTER	
	Sportmaster and Aerosedan	Sedans and Coupes	Cabriolet	Station Wagon	Sedans, Coupes and Sedan Delivery	
Structure	All steel inner and outer panels.			Hardwood frame, plywood panel.	All steel inner and outer panels.	
Binge*	Tan, concealed, at front.					
Latch	Easy setting latch bolt engages adjustable striker plate. Safety catch in plate.					
Ventipane	Class L-O-F Hi-Test Safety (laminated) Plate. Framed in polished stainless steel molding.					
Divider bar	Fixed. Outside, polished stainless steel; inside, golden walnut grain.			Fixed. Chrome plated.	Fixed. Outside, polished stainless steel; inside, golden walnut grain.	
Operation	Swivelled outward by crank handle.					
Lock	Spring-loaded sliding bolt lock.				Spring-loaded sliding bolt lock.	
Window	Class L-O-F Hi-Test Safety (laminated) Plate.			L-O-F Hi-Test Safety Sheet.	L-O-F Hi-Test Safety (laminated) Plate.	
Frame	Door structure.			Metal	Door structure.	
Operation	Lowered in door channels by crank handle.					
Lock	Operating crank handle.					
Reveal	Polished stainless steel.					

CONTINUED

**FRONT DOORS AND RELATED EQUIPMENT—Continued**

ITEM	FLEETLINE	FLEETMASTER			STYLEMASTER	
	Sportmaster and Aerosedan	Sedans and Coupe	Cabriolet	Station Wagon	Sedans and Coupes	Sedan Delivery
Window garnish moldings	Golden Walnut grain surface. Bright metal horizontal bead and bright metal medallion with ivory plastic insert. Two bright metal strips on either end at bottom.	Golden Walnut grain surface. Bright metal horizontal bead and bright metal medallion with ivory plastic insert slightly below glass.	Chrome plated metal frame. Golden Walnut grain window sill.	None. Window framed by natural wood finished frame-work of door.	Golden Walnut grain surface with Honey Beige painted horizontal stripe just below window glass.	
Side walls	See					
Scuff pads	Upholstery Materials					
Side wall trim decorations.	2 vertical sewed beads at center, 3 hor. at each side above 2 bright metal beads on scuff pad.	Chrome bead encloses 2 horizontal sewed seams above bright metal bead at top of scuff pad.	Horizontal seams and panel of vertical seams.		Sewed panel encloses 2 hor. sewed beads above metal scuff pad bead.	Sewed seam around door panel edge.
Hardware	Ternstedt, chrome plated, die cast handles. Interior handles have ivory plastic knobs and escutcheons. Escutcheons are edged with a bright metal ring. Stylemaster knobs are plain; others have copper-toned inserts.					
Key locks	Per both left and right front doors. Separate, covered locks below exterior handles. Same key as for ignition lock.					
Lock operation	Lock inside by pressing button on window sill. Slam door shut while holding outside door handle down. Open from inside by turning remote control door handle.					
Entrance steps	Fully concealed and protected by flared out lower portion of door. Ribbed black rubber "safety tread" surface. Foot scraper at front in body sill scuff plate.					
Drip protection	Pull length drip molding. Drip shield above ventipane.			Overhang of top.	Full length drip molding. Drip shield above ventipane.	

**REAR DOORS AND RELATED EQUIPMENT**

ITEM	FLEETLINE	FLEETMASTER	STYLEMASTER	
	Sportmaster	Sport Sedan	Station Wagon	Sport Sedan
Structure	All steel inner and outer panels.		Hardwood frame, plywood panel.	All steel inner and outer panels.
Hinges	Two, concealed, at front.		Two, exposed, at front.	Two, concealed, at front.
Latch	Easy acting latch bolt engages adjustable striker plate. Safety catch in plate.			
Ventilator pane	Glass	L-O-F Hi-Test Safety (laminated) Plate.		
	Location	In polished stainless steel frame in rear of door window frame.		
	Divider bar	Fixed. Outside, polished stainless steel; inside, Blistered Walnut grain.		
	Operation	Swivelled outward by crank handle.		
	Lock	Spring-loaded sliding bolt.		
Window	Glass	L-O-F Hi-Test Safety (laminated) Plate	L-O-F Hi-Test Safety Sheet.	L-O-F Hi-Test Safety (laminated) Plate.
	Operation	Lowered in door channels by crank handle.		
	Lock	Operating crank handle.		
	Reveals	Polished stainless steel.		

CONTINUED

**REAR DOORS AND RELATED EQUIPMENT—Continued**

ITEM	FLEETLINE	FLEETMASTER		STYLEMASTER
	Sportmaster	Sport Sedan	Station Wagon	Sport Sedan
Garnish moldings	Descriptions of front door window garnish moldings on preceding page apply.			
Side wall trim	See			
Scuff pads	Upholstery Materials			
Side wall trim decorations	2 vertical sewed beads at center, 3 horizontal sewed beads at each side above 2 bright metal beads on scuff pad.	Bright metal bead encloses two horizontal sewed beads above bright metal bead at top of scuff pad.		Sewed panel encloses 2 horizontal sewed beads above metal scuff pad bead.
Hardware	Turnstedt, chrome plated, die cast handles. Interior handles have ivory plastic knobs and escutcheons. Escutcheons are edged with a bright metal ring. Stylemaster knobs are plain; others have copper-toned inserts.			
Locks	Button on window sill. Press down to lock. Turn remote control door handle to open.			
Entrance steps	Fully concealed and protected by flared out lower portion of door. Ribbed black rubber "safety tread" surface.			
Drip protection	Pull body length drip molding.			

**REAR QUARTER WINDOWS**

ITEM	FLEETLINE	FLEETMASTER			STYLEMASTER			
	Aero-sedan	Town Sedan	Sport Sedan Sport Coupe	Cabriolet	Station Wagon	Sport Sedan	Town Sedan	All Coupes
Glass		Hi-Test Safety (laminated) Plate.			Hi-Test Safety Sheet, (2 panes).	Hi-Test Safety Solid Plate.	Hi-Test Safety (laminated) Plate.	Hi-Test Safety Solid Plate.
Operation	Lowers and locks by crank.	Slides back and locks by lever.	Rotates and locks by crank.	Rear pane slides forward. Button-on-sill lock.	Stationary.	Lowers and locks by crank.	Stationary.	
Reveals	Polished stainless steel.							
Garnish moldings	Golden Walnut grain surface with bright metal horizontal beads below glass and at bottom.	Golden Walnut grain surface with bright metal horizontal bead slightly below glass.	Chrome plated metal frame. Golden Walnut grain sill.	Natural finished wooden framework. Bright metal rear edge of front pane.	Golden Walnut grain.	Golden Walnut grain. Honey Beige painted stripe just below pane.	Golden Walnut grain.	
Hardware	Turnstedt, chrome plated, die castings. Crank knobs are ivory plastic with copper-toned inserts. Ivory plastic escutcheons with bright metal ring around edge.						Fleetmaster, but no knob inserts.	

**REAR WINDOW**

ITEM	FLEETLINE Sportmaster and Aero-sedan	FLEETMASTER		STYLEMASTER
	Sedans, Coupe	Cabriolet	Station Wagon	Sedans, Coupes, Sedan Delivery
Panes	1, curved to match body contours.	1, flat, in curtain.	2, flat, in lift gate.	1, curved to match body contours.
Glass	Hi-Test Safety Solid Plate.	Hi-Test Safety (lam.) Plate.	Hi-Test Safety Sheet.	Hi-Test Safety Solid Plate.
Garnish molding	Golden Walnut grain.	Tan Duco.	Natural finished wood.	Golden Walnut grain.
Ext. trim	Polished stainless steel.			Black rubber.

**LUGGAGE COMPARTMENTS**

ITEM	FLEETLINE		FLEETMASTER			STYLEMASTER		
	Aero-sedan	Sport-master	Sedans	Cabriolet, Sport Coupe	Station Wagon	Sedans, Coupes	Sedan Delivery	Char-sis
Type and location	Built-in compartment ("trunk") in rear of body.		On platform and tail gate. Seats removable.		Same as Fleet-master.	Panel body load space.		
Floor type and covering	Flat floor covered with brown rubber mat.		Flat floor and 3/4-width shelf. Brown rubber on both.		Brown linoleum on platform. Tail gate wood with plated steel skid strips.	Same as Fleet-master, but rubber in Sedans & Sport Coupe is black.	Body platform wood with steel skid strips.	Sedan under-body
Spare wheel and tire mounting	Vertical, in wall, against left wall of trunk.		Horizontal, below shelf in trunk.		Vertical, in metal cover, against rear of tail gate.		Horizontal, below platform at rear of body.	
Illumination	Prom. window in right tail lamp.				Dome light		Dome light	Tail lamp
Tool storage	Under front end of rear seat and/or loose in trunk.		With spare wheel in trunk.		In tool box under platform front.		In spare wheel compartment	Shipped loose.
Luggage compartment or rear end doors	Type	Deck	Trunk	Deck	Lift and tail gates	Same as in like models in Fleet-master line.	Panel door	
	Hinges	2, concealed		2, <sup>EXPOSED</sup> exposed	Lift: 2, exposed. Tail: full length, exposed.		2, exposed, at left.	
	Support	1 telescoping strut at left side.		2 telescoping struts at sides.	Lift: 2 adj. brackets. Tail: 2 covered chains.		1 door check at top.	
	Lock	In door handle. Operated by glove compmt. key.*						In door
Hardware	Chrome plated trunk door opening handle, license lamp and base in group at door center. Name plate in chrome script above. Fleetline models have emblem with trademark above name plate.				Chrome plated "T" handle on lift gate center.	Chrome plated handle. Central license and tail light unit.	Sedan parts less handle shipped loose.	

\* - Station Wagon tail gate lock operated by side door key, and spare tire lock by glove compartment key.

CARRIOLET CONVERTIBLE TOP

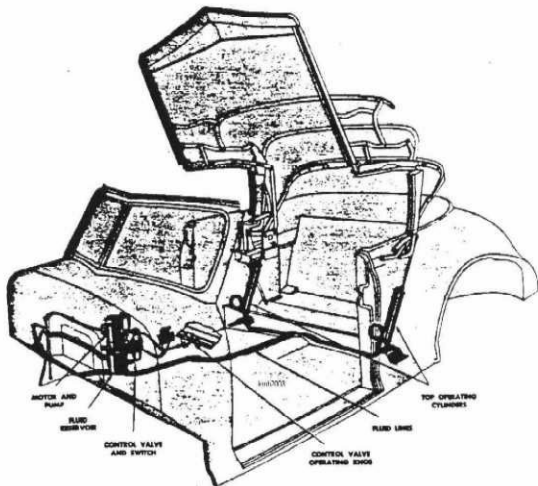

CONSTRUCTION AND OPERATION	
Material	Double texture, fabric top material.
Back	Opens downward. Continuous zipper fastener on top and two vertical edges.
Framework	Rear bow wood, remainder all-steel.
Storage	Top folds into recessed shelf around periphery of back of body.
Boot	Tailored from same material as top. Snap fastens to body upper sill.
Front latches	Three; at sides and center of top of windshield frame.
Operation	Automatic; powered by electric motor-driven, hydraulic pump.
Pump location	On left side of dash under hood.
Hydraulic cylinders	One at each side of body projecting upward to top framework between inner and outer rear quarter panels from rubber-cushioned pivot mounting on body floor pan.

Operation control	Push-pull knob, mounted below instrument panel to left of steering column. (Knob must be held in "Up" or "Down" position during operation because it always returns to neutral or "Stop" position when hand is removed.)
-------------------	--

COLOR COMBINATIONS		
Color Of Top Fabric	Leather and Imitation Leather	Color Of Body Paint
Black	Tan	Mayland Black
	Red	Battleship Gray
Tan	Tan	Oxford Maroon
	Blue	Freedom Blue
	Red	Sport Belge
Note: See RPO 377 for genuine leather and tan Bedford Cord seat trim; RPO 378 for full tan Bedford Cord seat trim.		

## CHASSIS FRAME

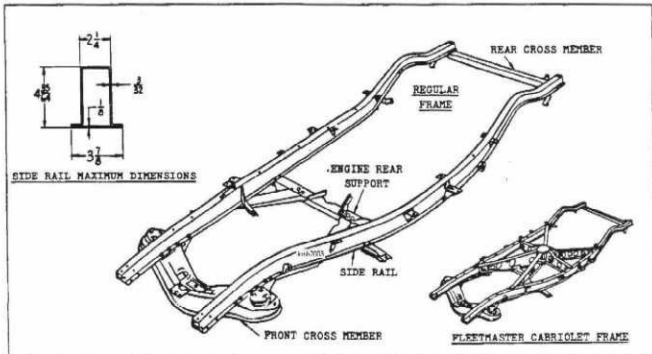

Make ----- Own  
 Type ----- Box-girder. Reinforced by steel floor of car body.  
 Construction ----- Two side rails connected by three structural cross members, all of flanged box section. In Fleetmaster Cabriolet, a VK structure of I-beam members takes place of

Engine Rear Support Cross Member.  
 Max. overall length ----- 169-9/16  
 Max. width (over side rail flanges) ----- 40  
 Material ----- Hot rolled steel, pickled  
 Material yield point ----- 39,000 lb. per sq.in.  
 Material elongation ----- 25% min. in 2 in.  
 Side rail section modulus -- 1.716 in.cu. per side

### FRONT SUSPENSION

Make ----- Own  
 Type ----- Independent S.L.A. (short and long arm wishbone type.) Assembled and aligned as a complete suspension unit.  
 Rated capacity ----- 2000 lb.

Outside diameter ----- 4-3/8  
 Pitch diameter ----- 3.791 (theoretical)  
 Free height ----- 14-1/4  
 Capacity (at ground) ----- 950 lb.  
 Working height ----- 9-5/8 at 1375 lb.  
 Height under curb weight (Sport } ----- 10-1/8  
 Sedan, Fleetmaster }  
 Deflection rate ----- 300 lb. per in.

#### WHEEL TRAVEL

Vertical ----- 4" both up and down from normal setting of loaded height position.  
 Wheel to spring ratio --- 1.64:1. Wheel travels in vertical path 4" from normal setting position at rate of 111 pounds per inch. Spring travels 2-7/16" at rate of 300 pounds per inch.  
 Wheel travel for steering ----- 36° from neutral to stop.

#### SPRING BUMPERS

Type ----- Rubber (2, compression and rebound)

#### SHOCK ABSORBERS

Make ----- Delco  
 Model number ----- 2200-A & B  
 Type ----- Hydraulic, parallel cylinder, double-acting (end-to-end discharge).  
 Valve code number-compression valve ----- Ad-5  
 -----rebound valve ----- 1.5D  
 Piston diameter ----- 1-1/2  
 Fluid recommended ----- G.M. Shock Insulating Fluid.  
 Fluid capacity ----- 5 to 6-1/4 ounces

#### SPRINGS

Make ----- Own  
 Type ----- Right hand helical coil  
 Material ----- Silico-manganese steel  
 Gauge ----- .578-.582 diameter  
 Number of coils ----- 11-5/16 approximately (9.6 coils active)

CONTINUED

**FRONT SUSPENSION—Continued**

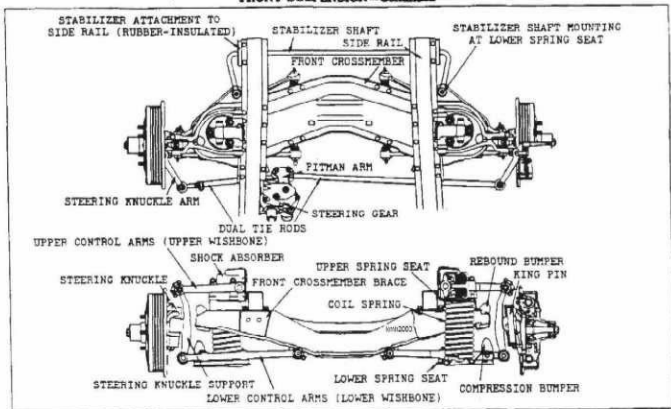

**RIDE STABILIZER**

Type ----- Torsion bar in rubber bushings  
 Mounting ----- Bolted to both lower spring seats

**STEERING KNUCKLE**

Type ----- Reversed Elliott  
 Spindle diameter—at inner bearing — 1.260-1.2806  
 —at outer bearing -- .7490-.7492

**KING PIN**

Diameter ----- .6660-.6665  
 Bushings—inside diameter ----- .667-.668  
 —length ----- 1-5/16  
 Thrust bearings—make and type ---- Various, Ball  
 —inside diameter ----- .666-.693  
 —outside diameter ----- 1-5/8  
 —width ----- .5175-.5675

**FRONT WHEEL BRGS.**      INNER      kmh2003      OUTER  
 Make ----- New Departure  
 Part Number ----- N.D. 909052 ---- N.D. 909001  
 Type ----- Cup and Cone  
 Inside dia. ----- 1.2810-1.2815 -- .7498 - .7503  
 Outside dia. ----- 2.9625-2.9635 -- 2.0795-2.0805  
 Width ----- 1.135 - 1.155 ---- .696 - .718  
 Lubrication ----- Pack with high melting  
 point front wheel bearing grease.

**FRONT WHEEL ALIGNMENT (Service)**

Cross-wise inclination of king pin -- 4-3/4° ± 30'  
 CAMBER ----- -1/4° ± 30'  
 Caster ----- 0° ± 30'  
 Toe-in ----- 0 to 1/8  
 Toe-out on turns—outside wheel ----- 20°  
 —inside wheel ----- 24° ± 2°

CONTROL ARM BEARINGS	UPPER CONTROL ARMS			LOWER CONTROL ARMS			
	Pivot Bolt	Front Bushing	Rear Bushing	Pivot Bolt	Bolt Bushing	Shaft Bushing	Shaft Ends
Type	Threaded						
T h e	Ends	11 pitch, single		11 pitch, single			
e	Center	14 pitch, double					
Major diameter	Front	.644-.662		.735-.756	.774	.689	.853-.859
d s	Center	.976-.980	.694 minimum	.724-.742	minimum	minimum	
s	Rear	.644-.662		.714-.732			
Mounting	Clamp locs			Self locking			
Seal	Synthetic rubber, self sealing						





## REAR AXLE AND DRIVE

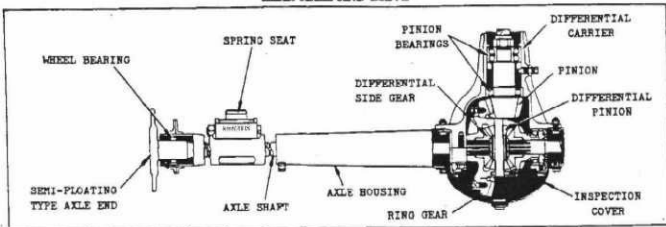

Type ----- Torque tube drive. Through fully enclosed universal joint and propeller shaft.  
 Drive medium ----- Through rear chassis springs

Lubricant Capacity ----- 3-1/2 pints  
 Pinion Fr. brg. retain. nut torque -- 200-240 ft. lb.

### REAR AXLE

Make and type ----- Own. Semi-floating  
 Rating ----- 3000 lb.

Final drive gears	Reg. RPOs	
Type	Spiral hypoid	
Ratio	4.11:1   3.73:1	
Number of teeth	37 & 9   41 & 11	
Gear backlash	.005 to .008	
Total gear reduction (rear axle ratio x transmission ratio).	1st.	12.08   10.97
	2nd.	6.90   6.27
	3rd.	4.11   3.73
	Rev.	12.08   10.97
	4th.	6.90   6.27
Axle shaft torque (ft. lb.): (total gear red. x engine max. torque x efficiency factor -- .90 in 3rd, others .85).	1st.	1726   1567
	2nd.	985   895
	3rd.	621   564
	Rev.	1726   1567
* RPO 211A, 3.73:1 axle with regular transmission. RPO 201B, 3.73:1 axle with heavy duty trans.		

Bearings	Front Pinion	Rear Pinion
Number	954394	Hyatt 125630
Type	2-Row Ball	Roller
I.D.	1.1807-1.1811	1.8287-1.8291
O.D.	2.8341-2.8346	3.1246-3.1250
Width	1.1825-1.1875	.743-.748

Bearings	Differential	Wheel
Number	Hyatt 127861	Hyatt 111119
Type	Barrel Roller	Roller
I.D.	1.6924-1.6929	1.5800-1.5807
O.D.	2.9523-2.9528	2.4056-2.4062
Width	.669	.742-.750

### UNIVERSAL JOINT

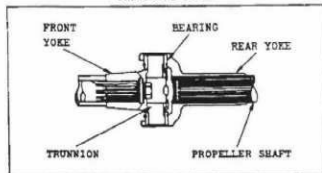

Differential type ----- 2 pinion  
 Diff. carrier type ----- 1 piece malleable iron  
 Housing type ----- Pressed steel banjo, 2 pieces welded together along seam.  
 Inspection cover ----- Pressed steel  
 Axle shaft-material and type ----- Forged steel.  
     Wheel drive flange integral with shaft.  
     -in. diameter ----- 63/64  
 Pinion-mounting ----- Overhung  
     -adjustment -- By shims and tapered collar  
     -thrust ----- Against front bearing  
 Are pinion bearings preloaded? ----- Yes, in manufacture.  
 Are pinion bearings carried in sleeve? ----- No  
 Are differential bearings preloaded? ----- Yes  
 Diff bearing cap bolt torque ----- 65-80 ft. lb.  
 Lubricant recommended ----- SAE 90 Passenger Car Hypoid Lubricant or "All Purpose" Lubricant.

Make and type -- Own. Yoke and spider (trunnion)  
 Trunnion-material -- Drop forged steel, hardened.  
     -pin dia. ----- .6835-.6845  
 Bushing-I.D. ----- .687-.688  
     -effective length ----- 17/32  
 Lubrication ----- Self, from transmission

### PROPELLER SHAFT

Make and type ----- Own. Tubular  
 Outside diameter ----- 1.995-2.005  
 Wall thickness ----- .063-.067

### DRIVE SYSTEM SPLINES

Type of splines	Internal	External
Clutch disc hub and transmission clutch gear shaft	Width .174 - .176	.1705 - .1725
	I.D. .920 - .925	.918 max.
	O.D. 1.134 - 1.144	1.110 - 1.121
Transmission mainshaft and universal joint front yoke	Width .1475 - .1483	.1458 - .1473
	I.D. .890 - .891	.853 - .863
	O.D. 1.003 - 1.017	.973 - .980
Propeller shaft front end and universal joint rear yoke	Width .0951 - .0961	.0921 - .0941
	I.D. .893 - .897	.8520 - .8700
	O.D. 1.0835 - 1.0935	1.0642 - 1.0657
Prop. shaft rear end coupling and rear axle drive pinion shaft	Width .0951 - .0961	.0931 - .0951
	I.D. .985 - .989	.965 - .973
	O.D. 1.0835 - 1.0935	1.066 - 1.074
Differential side gear and axle shaft	Width .180 - .183	.178 - .180
	I.D. 1.039 - 1.041	1.004 - 1.014
	O.D. 1.186 - 1.193	1.1525 - 1.1575
	Number 10 (straight side)	

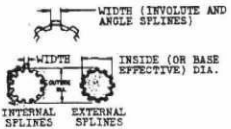
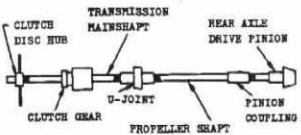

### BRAKES

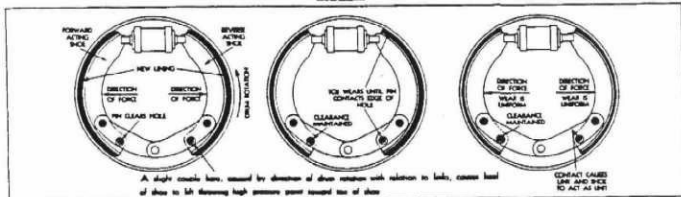

#### SERVICE BRAKES

Make ----- Own  
 Type ----- Hydraulic, 4-wheel,  
 Internal expanding, double-articulated shoe.  
 Brake drum-type ----- Composite (cast alloy iron  
 rim and cooling ribs; pressed steel web.)  
 -diameter ----- 11 (both front and rear)  
 Braking pressure-front ----- 52-1/2%  
 -rear ----- 47-1/2%  
 Brake lining-material ----- Full-moulded  
 asbestos composition.  
 -width ----- 1-3/4  
 -thickness ----- .187-.194  
 -length per wheel (inside arc) ----- 22-5/8  
 -clearance ----- Adjust to slight drag,  
 back off 4 notches.  
 -total effective lining area ----- 161 sq.in.  
 -car weight e/effective lining area --- 22.70  
 lb./sq.in.  
 \* 3655 lbs. (shipping weight of Stylemaster Sport  
 Sedan plus 525 lbs.) see page 14.

Main cylinder-diameter ----- 1  
 -piston travel ----- 1-11/32 max.  
 Wheel cylinder-diameter front ----- 1-1/4  
 -diameter rear ----- 1-3/16  
 -piston travel ----- .113  
 Braking ratio-pedal ----- 4.63 to 1 approx.  
 -hydraulic ----- 11.9 to 1 approx.  
 -average overall ----- 55.1 to 1 approx.  
 Foot pedal-travel ----- 6-9/32  
 -mounting ----- With main cyl. to frame  
 -pad material ----- Rubber  
 Brake system fluid capacity --- .68 pint approx.  
 Brake fluid recommended ----- Delco Super #10  
 Vacuum booster ----- None

#### HAND BRAKES

Make ----- Own  
 Type ----- Mechanical. Pull rods and cables  
 operate the two rear service brakes.  
 Total effective lining area ----- 80 sq.in.  
 Lever mounting ----- To cowl

POWER PLANT GENERAL INFORMATION

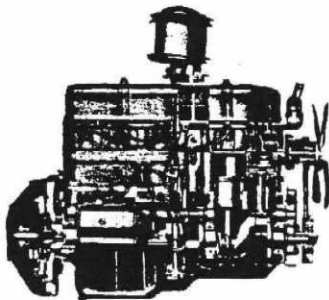

"THRIFT-MASTER" ENGINE BASIC DESIGN DATA

Type ----- 6 cylinder, valve-in-head  
 Bore x stroke (nominal) ----- 3-1/2 x 3-3/4  
 Piston displacement ----- 216.5 cu.in.  
 Compression ratio ----- 6.5:1 (no option)  
 Taxable (SAE) horsepower ----- 29.4  
 Engine idling speed ----- 450-500 RPM  
 Compression pressure at cranking speed 110 pounds  
 at 210 to 220 RPM with engine hot.

ADVERTISED MAXIMUM ENGINE PERFORMANCE

Gross brake horsepower ----- 90 at 3300 RPM  
 Net brake horsepower ----- 83 at 3200 RPM  
 Gross torque ----- 174 ft.lb. at 1200 to 2000 RPM  
 Net torque ----- 168 ft.lb. at 1100 RPM

ADVERTISED CAR PERFORMANCE

These data are intended primarily for use in trade journal specification tables which require such information for the standard, lowest-priced, 6-passenger, 4-door sedan in each line. The figures shown are based on the curb weight of the vehicle with regular equipment including a spare tire plus 450 pounds for three passengers.

SPORT SEDANS  
Style- Fleet-  
master master

Performance weight (pounds) ----- 3710 -- 3765  
 Car weight/adv. gross b.p. ----- 41.22 -- 41.63  
 Car weight/cu.in. piston displ. - 17.13 -- 17.39  
 Adv. horsepower/cu.in. displ. --- .42 -- .42  
 Power displ. (cu.ft./car mile) - 191.3 -- 191.3  
 Displ. factor (cu.ft./ton mile) 103.1 -- 101.6  
 \* -crankshaft rev./mi. x piston displ./2

1726

6 - power displ./performance weight in tons.

6-1-47

ENGINE SPEED AND PISTON TRAVEL

With regular (4.11:1) or RPO 201 (3.73:1) rear  
 axles: ----- 4.11:1 -- 3.73:1  
 Crankshaft revolutions/mile --- 3054 -- 2771  
 Crankshaft RPM/mile/hour - 1st - 149.6 -- 135.8  
 - 2nd - 85.5 -- 77.6  
 - 3rd - 50.9 -- 46.2  
 Piston travel (ft./mile) ----- 1909 -- 1732  
 Piston speed/mile/hour (ft./min.  
 in 3rd speed) ----- 31.8 -- 28.8

WEIGHTS (dry)

Engine and clutch (complete) ----- 567 lb.  
 Engine, clutch, and transmission ----- 617 lb.

POWER PLANT MOUNTING

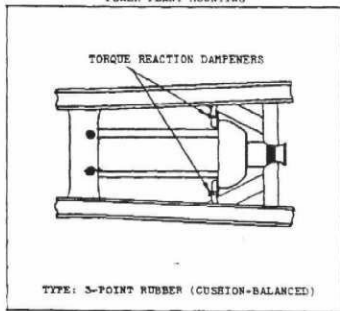

ENGINE PERFORMANCE

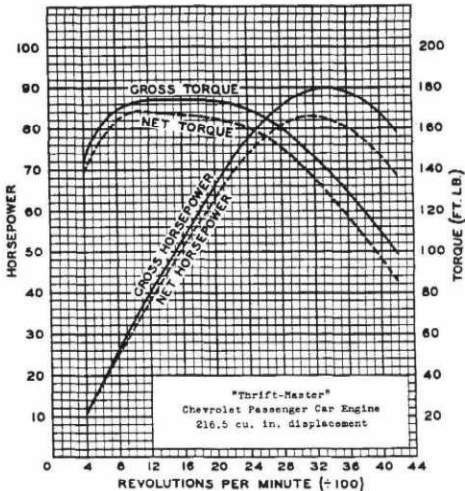

The engine performance curves shown on this sheet are true copies from Chevrolet engine test report 9616-44. They represent the full throttle performance of a "Thrift-Master" Chevrolet passenger car engine (216.5 cu. in. displacement) as obtained from dynamometer test data which were corrected to the standard barometric pressure of 29.92" Hg. and the standard temperature of 80° F.

GROSS POWER and TORQUE were obtained in a regular dynamometer test with the dynamometer exhaust system, no fan, generator not charging, and optimum spark advance.

NET POWER and TORQUE were obtained from a dynamometer test simulating actual operating conditions when the engine is in its vehicle. It includes the use of the regular muffler and pipes, the fan in operation, the generator charging and automatic spark advance.

8-1-47

CHEVROLET 1947 SPECIFICATIONS—PASSENGER

July 6, 1947  
The data on this sheet are true as represented.  
CHEVROLET - CENTRAL OFFICE - ENGINEERING DEPT.  
DIVISION OF GENERAL MOTORS CORPORATION

R. B. Wuerfel  
Transport Engineer

State of Michigan  
County of Wayne

On this 6th day of July 1947 personally appeared before me, R. B. Wuerfel, known to me to be such, who makes oath that the data on this sheet are true as represented.

Notary Public, Wayne County  
My commission expires August 8th, 1947

## CYLINDER AND CASE AND HEAD

Material ----- Cast alloy iron Bore diameter ----- 3.4995-3.5015  
 Offset ----- None Cyl. head bolt torque (service) -- 75-80 ft. lb.

### CRANKSHAFT AND BEARINGS

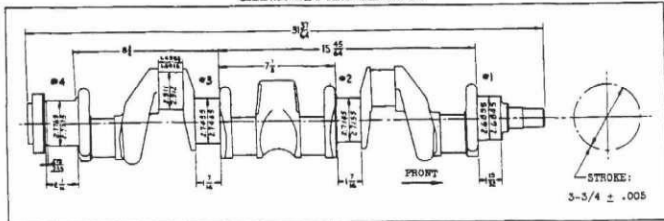

#### CRANKSHAFT

Material ----- Drop-forged steel  
 Weight ----- 68 lb.  
 End play ----- .004-.007  
 Counterweights ----- 7

#### HARMONIC BALANCER (Vibration Dampener)

Type ----- Oscillating (Rubber-floated)  
 Fan drive pulley diameter ----- 6-1/32

#### MAIN BEARINGS

Material ----- Steel-backed babbit  
 Type ----- Slip-in

Removable ----- From below  
 Necessary to align ream ----- Yes  
 Clearance ----- Selective fit with solid shims  
 End thrust taken on ----- #3  
 Bearing bolt torque ----- 100-110 ft. lb. with oiled threads.

Brg.	Inside Dia.	Length	Proj. Area @
#1	2.6865-2.6875	1-3/16	2.603 sq. in.
#2	2.7175-2.7185	1-3/16	2.633 sq. in.
#3	2.7485-2.7495	1-7/16	2.629 sq. in.
#4	2.7795-2.7805	1-5/8	3.909 sq. in.

\* - Based on effective length, i.e. overall length shown above, less oil groove and chamfers.

### CAMSHAFT AND BEARINGS

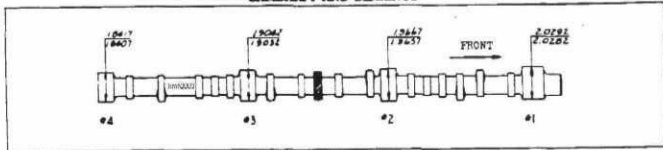

#### CAMSHAFT

Material ----- Drop-forged steel  
 Minimum diameter ----- 1-3/32  
 End play ----- Free to .003 maximum  
 Ramp-inlet ----- .011  
 -exhaust ----- .014

#### DRIVE

Make ----- Own  
 Type ----- Helical gear  
 Drive gear (on camshaft) material ----- Bauxelite and fabric composition with steel hub

6-1-47

Drive gear (on crankshaft) material ----- Steel

#### BEARINGS

Material ----- Steel-backed babbit  
 Clearance on diameter ----- .0015-.0035  
 Thrust taken at ----- #1

Brg.	Inside Dia.	Length	Proj. area @
#1	2.0307-2.0317	1-1/8	2.285 sq. in.
#2	1.9682-1.9692	15/16	1.846 sq. in.
#3	1.9067-1.9067	15/16	1.787 sq. in.
#4	1.8432-1.8442	15/16	1.728 sq. in.

@ - Based on overall length shown above.

## PISTON-PIN-RINGS

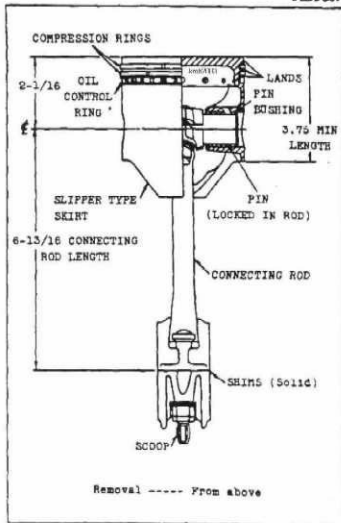

Skirt clearance in cylinder bore { Pass on .0015  
Hold on .003

### Oil groove:

Diameter ----- 3.116-3.136  
Holes-number and size ----- 14, 5/32 drill  
Head thickness at center ----- .180-.190  
Piston pin bushing:  
Type ----- Pressed in piston  
Material ----- Cast bronze  
Inside diameter ----- Slip fit on pin  
Length (each) ----- 15/16  
Finish ----- Diamond bored  
Weight of piston and bushing assy. --- 1.686 lb.  
Weight of piston, bushing, rings, pin, and connecting rod upper end x 6 ----- 15.46 lb.

### PISTON PIN

Material ----- Chromium steel (file hard case)  
Diameter ----- .8645-.8650  
Length ----- 3.135-3.165  
Taper limit in full length ----- .0002  
Weight ----- .32 lb.  
Clearance in bushing ----- Slip fit

### COMPRESSION RINGS

Material ----- Cast alloy iron  
surface treated with a wear resistant coating  
Type ----- Taper face  
Number per piston ----- 2  
Width ----- .1235-.1240  
Wall thickness ----- .155 max.  
Gap clearance ----- .005-.015  
Ring clearance in groove ----- .0015-.003  
Weight (each) ----- .05 lb.

### OIL CONTROL RING

Material ----- Cast alloy iron  
Type ----- Wide-slot  
Width ----- .1860-.1865  
Wall thickness ----- .155 max.  
Gap clearance ----- .005-.015  
Ring clearance in groove ----- .0020-.0035  
Weight ----- .05 lb.

### PISTON

Make ----- Own  
Features ----- Flat head, oval, slipper skirt  
Material ----- Cast alloy iron,  
surface treated with a wear resistant coating  
Diametral relief at lands ----- .015-.023  
Compression ring groove diameter ----- 3.115-3.163

### CONNECTING RODS

Type ----- Rod clamps piston pin  
Material ----- Drop-forged steel  
Assembly center of gravity --- 5.322 from piston pin  
Rod width at piston pin ----- 1.125-1.127  
Rod width at crankpin ----- 1.490-1.494

### Crankpin bearing:

Type ----- Spun (Centrifugally cast)  
Diameter ----- 2.3135-2.3140  
Effective length (overall length less oil groove and chamfers) ----- 1.138  
Material ----- High lead babbit

Clearance on diameter ----- Selective fit  
Projected area per rod - (based on effective length) ----- 2.633 sq.in.

Assembly weight ----- 1.96 lb.  
Upper end weight ----- .42 lb.  
Lower end weight ----- 1.54 lb.  
Total rotating weight (weight of lower end x 6 connecting rods) ----- 9.24 lb.  
End play ----- .004-.012  
Recommended bolt nut torque ----- 40-50 ft.lb.  
with oiled threads

6-1-47

## VALVE TRAIN

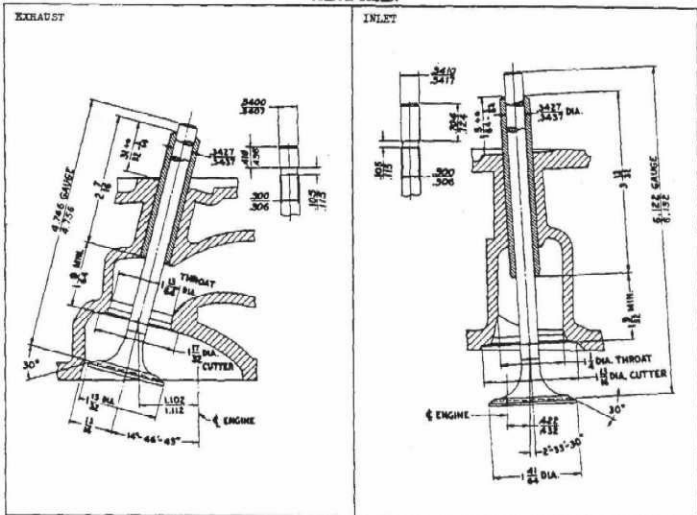

VALVES

VALVE STEM GUIDES

Make ----- Own  
 Material ----- Extruded steel  
 Stem end style ----- Grooved for keys  
 Lift-exhaust valve ----- .3118  
     -inlet valve ----- .2941  
 Distance between valve centers --- 1-21/32 (measured along centerline of engine).  
 Operating tappet clearance for valve timing ----  
 ----- See valve lash shown below  
 Lash (with engine normalized  $\epsilon$ ): Inlet Exhaust  
     Regular engine ----- .006 .013  
     RFC 224A engine w/Econ. equip. ----- .010 .016  
 $\epsilon$  - To normalize engine, run it at fast idle (approximately 600 RPM) until a constant oil temperature is maintained for a period of five minutes.

### TAPPETS

Type ----- Cylindrical  
 Material ----- Cast alloy iron  
 Outside diameter ----- .989-.990  
 Lift-exhaust valve ----- .2111  
     -inlet valve ----- .1991  
 Clearance ----- Selective fit  
 Hydraulic valve lifters ----- None  
 8-1-47

Type ----- Removable  
 Clearance with stem-exhaust ----- .002-.0037  
     -inlet ----- .001-.0027

### VALVE ROCKER ARMS

Material ----- Malleable iron casting  
 Ratio (cam lift to valve lift) ----- 1.477:1  
 Torque of valve rocker shaft support bolts and nuts ----- 25-30 ft. lb.  
 Bearing-type ----- Rocker arm I.D.  
     -inside diameter ----- .7925-.7935  
     -length ----- 15/16

### VALVE SPRINGS—LENGTH AND PRESSURE

Valve closed ----- 1.821 at 54-62 lb.  
 Valve open ----- 1.505 at 124-140 lb.  
 Out of engine (free) length ----- 2-1/8

### VALVE SEATS

Material ----- Cast alloy iron (cylinder head)  
 Inserts ----- None  
 Cooling ----- Jets of water under pressure  
 Width in head-exhaust valve ----- .062-.093  
     -inlet valve ----- .035-.060

## ENGINE LUBRICATION SYSTEM

### METHOD OF LUBRICATION

Type ----- Chevrolet "specialized" (pressure, pressure stream and splash).  
Main bearings -- Direct pressure through drilled passages in the cylinder case to the bearings.  
Cams/haft bearings ----- Direct pressure through passages from main bearings.  
Timing gears ----- Gravity feed  
Connecting rod bearings ----- Pressure streams directed against connecting rod scoops.  
Cylinder bores and piston pins ----- Splash  
Valve mechanism ----- Pressure.  
Oil is piped from oil distributor (high pressure side) past bleed hole (to regulate pressure) and through metering hole; then through water jacket (to condition temperature) and finally to rocker shaft and arms. Valve stems, springs, and push rod ends are gravity fed from rocker arms.  
Water pump bearing -----  
-- Permanently lubricated, sealed, ball bearing.

### OIL PUMP

Type and drive ----- Gear, from camshaft  
Capacity (gallons per minute, hot oil) -----  
----- 7.16 at 4000 engine RPM  
Normal oil pressure ----- 14 lb. at 2000 engine RPM (equivalent to 39 MPH with regular

equipment; 43 MPH with RPO 201 3.73:1 rear axle).  
Oil pressure relief valve opens at ----- 60PSI  
Cleaner type -- 20 mesh x .015 non-corrosive steel wire screen; by-pass in intake side of oil pump.

### MISCELLANEOUS

Crankcase oil filler -- Combined with ventilator  
Crankcase oil level gauge type ----- Rod  
Oil pressure gauge ----- See "Instrument Panel"  
Crankcase ventilator type ----- Suction  
Oil filter -make ----- AC (RPO 237A)  
----- capacity (dry) ----- 2-1/2 qt.  
----- flow ----- Approximately 20 gal./hr.  
Oil cooler ----- None available

### OIL PAN

Capacity ----- 5-1/2 qt., dry; 8 qt., for refill  
Drain ----- Plugged hole in rear of pan  
Torque, bolts, on corners ----- 12-1/2 to 16 ft.lb.  
Torque, screws, on flanges ----- 6 to 7-1/2 ft.lb.

### LUBRICANT RECOMMENDED

Temperature	Grade
Not lower than 32°F. -----	20W or SAE 20
As low as plus 100°F. -----	20W
As low as minus 10°F. -----	10W
Below minus 10°F. -----	10W, plus 10% kerosene

## FUEL AND EXHAUST SYSTEMS

### FUEL TANK

Type ----- 2 stamped pans, seam-welded together  
Capacity ----- 15 gallons  
Mounting ----- Clamped to underside of underbody below trunk on Sedans, Sport Coupe, Cabriolet, and Station Wagon; behind seat between underbody and platform on Business Coupe, and Sedan Delivery.  
Filler location ----- At rear of right rear fender on Sedans, Sport Coupe, Cabriolet, and Station Wagon; on right side of body ahead of rear fender on Business Coupe and Sedan Delivery.  
Fuel gauge make and type ----- AC, electric

### FUEL PUMP

Make and model ----- AC, model AF  
Type ----- Mechanical (diaphragm) "high reserve"  
Drive ----- From camshaft  
APM throw ----- 1/4 at camshaft  
Air dome ----- Yes (inlet and outlet)  
Filter ----- 120 mesh screen on dome

### CARBURETOR

Make ----- Carter  
Model ----- with regular equipment ----- W1-5745  
----- with economy equip., RPO 224 ----- W1-616S  
Type --- Single adjustment, balanced, down-draft  
Size (main venturi throat I.D.) -----  
----- Regular engine 1-1/4, RPO 224 1-1/16.  
Choke ----- Manual (no automatic choke)  
S-1-47

Idle adjustment, number of turns open:  
-regular carburetor ----- 1-1/4 to 2-1/4  
-economy carburetor ----- 1 to 2  
Float level ----- When closed, top of float measures 1/2 below finished surface of cover.  
Supercharger ----- None  
Manifold heat control -- Automatic (thermostatic)  
Manifold cover ---- With economy equip., RPO 224

### AIR CLEANER

Regular --- AC, with silencer and flame arrester  
RPO 216A ----- AC, regular truck type  
RPO 216C --- AC, oil bath type (1 lb. dirt capacity) combined with silencer and flame arrester; not used with governor equipment.  
RPO 216F --- AC, oil bath type (2 lb. dirt capacity) combined with flame arrester; used with gov. equip.  
RPO 216G ----- AC, oil bath type (1 lb. dirt capacity); used with gov. equip.

### OCTANE SELECTOR

Type ----- Manual 20° range

### MUFFLER

Make ----- Various  
Type ----- Diffusion and resonance, reverse flow  
Size (outside) --- 5-1/16 x 7-5/16 (oval) x 18 long  
Mounting ----- Single point rubber  
Exhaust pipe O.D. ----- 1-7/8  
Tail pipe I.D. ----- 1-11/16



## ENGINE COOLING SYSTEM

### METHOD AND CAPACITY

Cylinder cooling ----- Pull stroke length  
water jacket with water around each cylinder.  
Valve seat cooling ----- "Nozzle jet"  
system directs water under pressure against seats.  
Cooling system water capacity ----- 15 qt.  
Sealed cooling system ----- No

### RADIATOR CORE

Make and type ----- Harrison, ribbed cellular  
Material ----- All copper  
Size ----- .20 x .360 x 2  
Front area ----- 374 sq.in.  
Radiator shutter ----- None  
Radiator pressure cap ----- None  
Radiator overflow tank ----- RPO 271A

### RADIATOR HOSE

Item	Inlet	Outlet
Quantity	1	2, joined by steel tube
Location	Cyl. head to core	Core to water pump
Size	1-1/4 I.D. x 6-3/4	1-1/2 I.D. x 4-7/16
Material	Spec. molded re- inforced rubber	Reinforced rubber

### WATER THERMOSTAT

Make ----- Harrison  
Type ----- Bellows operating poppet valve  
Location ----- In cylinder head outlet  
Pressure relief valve ----- None  
By-pass for recirculation ----- None

Valve action at 29" Hg. baromet- ric pressure	Regular	RPO 224 Economy Equip.	With anti-freeze Alco- hol	Per- ma- nent
Start to open	140-147	156-165	148-155	166-174
Pully open	170	185	173	194

### ENGINE FAN

Make and type ----- Own, 4 staggered blades  
Diameter with regular equipment ----- 15-3/4  
-with RPO 201, 3.73:1 axle ----- 16-1/4  
Pulley size ----- 28<sup>o</sup>v x 4-21/64 dia.  
Fan to engine speed ratio ----- 1.405:1  
Fan belt-material ----- 1-piece vulcanized fabric  
-size -- 11/16 max. width, 42-7/8 outside

### WATER PUMP

Type ----- Centrifugal  
Drive ----- By fan belt  
Location ----- On front of cylinder and case  
Capacity ----- 47 gal./minute  
at 4000 engine RPM (78.2 MPH, with regular equip-  
ment; 86.2 MPH, with RPO 201, 3.73:1 axle).  
Impeller type ----- Vane  
water pump and fan bearing and shaft assembly:  
-number ----- N.D. 954252  
-type ----- Ball  
-O.D. ----- 1.1806-1.1811  
-width ----- 1-21/32  
-lubrication ----- Permanently lubricated  
Seal --- Molded rubber sealed with rubber cement  
Seal adjustment --- Automatic, by spring tension

## ENGINE ELECTRICAL SYSTEM

### GENERATOR

Make ----- Delco-Remy  
Model ----- 1102667  
Type ----- 2 brush, shunt wound  
Rated voltage ----- 6 to 8  
Ventilation ----- By fan in generator pulley  
Driven by ----- Fan belt  
Pulley size ----- 28<sup>o</sup>v x 3-11/32 dia.  
Speed ratio (gen. to engine) ----- 1.83:1  
Generator } - with regular equipment ----- 93.5  
              } - with RPO 201, 3.73:1 axle ----- 84.9  
Maximum output (controlled charging rate) - not:  
-amperes ----- 35  
-voltage ----- See voltage regulator  
-generator RPM ----- 2400 and up  
-car } - with regular equipment -- 25.7 and up  
-RPM } - with RPO 201, 3.73:1 axle-28.3 and up  
Bearings: Commutator end Drive end  
-number ----- G12823 ----- N.D. 903203  
-type ----- Bronze bushing ----- Ball  
-I.D. ----- .562-.563 ----- .6590-.6693  
-O.D. ----- .783-.784 ----- 1.5743-1.5748  
-width ----- 51/64 ----- .6674-.4724

Generator speed at cut-in ----- See cutout relay  
Car speed at cut-in ----- See cutout relay  
Brush spring tension ----- 25 oz.  
Rotation (drive end) ----- Clockwise

### VOLTAGE AND CURRENT REGULATOR

Make and model ----- Delco-Remy 1118201  
Type ----- Vibrator  
Voltage regulator:  
-volts ----- 7.2 to 7.4  
-temperatures ----- Operating  
-average air gap ----- .070  
Current regulator:  
-amperes ----- 34 to 36  
-temperatures ----- Operating  
-average air gap ----- .080  
Cutout relay:  
-voltage at closing ----- 6.2 to 6.7  
-generator armature speed ----- 800 RPM  
-car MPH at } - with regular equipment -- 8.6  
              } closing RPM } - with RPO 201, 3.73:1 axle 9.4  
-amperes to open (reverse current) --- 0 to 4  
-average air gap ----- .020

CONTINUED

## ENGINE ELECTRICAL SYSTEM—Continued

### BATTERY

Make and model ----- Delco, 15X4W  
 Size ----- 9 long x 7 wide x 8-5/8 high  
 Voltage ----- 6  
 Capacity ----- 100 ampere hours at 20-hour rate  
 Bench normal charging rate ----- 7 amp.  
 Cell arrangement ----- 3, side-to-side  
 Plates per cell ----- 15  
 Terminal grounded ----- Negative  
 Location ----- At right side under hood

### STARTING

Starting device ----- Mechanical  
 over-running clutch actuated directly by pedal.  
 Starting operation -----  
 --- with ignition switch ON, depress starter pedal.  
 Pinion meshes ----- From front of flywheel  
 Pinion teeth ----- 9  
 Flywheel teeth ----- 139, 1/2 wide, 13.9 P.D.  
 Flywheel bolt recommended torque --- 50-65 ft.lb.  
 Gear ratio (starter armature to flywheel) - 1:15.44  
 Normal engine cranking RPM (60°P. air) ----- 125

### STARTING MOTOR

Make and model ----- Delco-Remy, 1107061  
 Rotation (commutator end) --- Counter-clockwise

Bushings	Commutator end	Drive end	
Type	Regular- Cast iron end frame	Optional- Bushings with alum- inum end frame	Rolled bronze graphite.
I.D.	.5625-.5635	.499-.501	
O.D.	.6245-.6255	.5615-.5625	
Width	.1516	.12	.779-.784

Testing: Lock test No load test

-ampere draw ----- 525 ----- 65  
 -volts ----- 3.4 ----- 5  
 -torque ----- 12 ft.lb. -----  
 -RPM ----- 5000

Brush spring tension ----- 24-26 oz.

### IGNITION SYSTEM

Type ----- Separate units,  
 high tension distributor ground return system  
 with centrifugal and vacuum spark advance, high  
 intensity spark with automatic polarity reversing  
 switch for breaker points, water-proof coil.  
 Ignition cable make ----- Packard Electric  
 Ignition lock make ----- Rochester Products  
 -type --- Key operated lock switch;  
 armored cable from coil to switch.

### DISTRIBUTOR

Make and model ----- Delco-Remy, 1110090  
 Current source ----- Generator or battery  
 Breaker contact opening and nominal contact angle:  
 -with new breaker lever --- .016-.024 --- 34°  
 -with old breaker lever --- .015-.022 --- 39°

Breaker arm tension ----- 17-21 oz.  
 Polarity reversing switch --- On starting motor top  
 Vacuum control part number ----- 1116043  
 Condenser (service) part number ----- 1908757

Automatic spark advance:	Advance begins	Pull advance
Vacuum control	7" Hg. min.	20" at 12" Hg. min.
Centrifugal	600 RPM	32.5° to 39.5° at 3450 RPM and up.

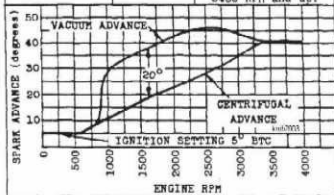

### COIL

Make and model ----- Delco-Remy, 1115380  
 Location ----- Engine right side  
 Amperes drawn --- 4.5, engine stopped; 2.5, idling

### SPARK PLUGS

Make and model ----- AC, model M8  
 Thread size ----- 10 mm  
 Recommended gap ----- .040  
 Recommended torque ----- 10 to 12 ft. lb.

### ENGINE TIMING

Timing spark advance ----- 5° BTC  
 Timing marks location ----- On flywheel  
 Firing order ----- 1-5-3-6-2-4

### VALVE TIMING (theoretical)

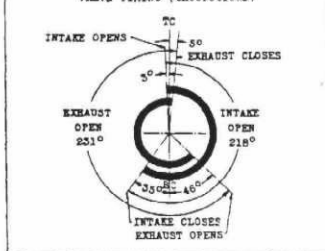

## CLUTCH

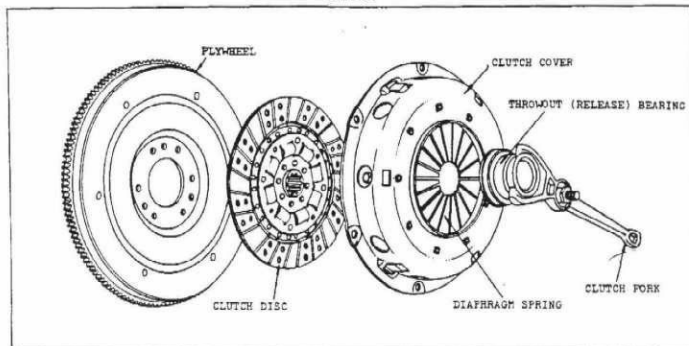

ITEM		REGULAR CLUTCH	HEAVY DUTY TRUCK TYPE, RPO 227A	
Type		Single dry plate.		
Rated torque capacity		200 foot pounds.		
Semi-centrifugal?		No		
Vacuum control or fluid coupling		None		
Drive		Direct to flywheel face.		
Ventilation		Vaness cast in pressure plate.		
Diaphragm spring	Pressure in flat position	1100 to 1225 pounds	1175 to 1275 pounds	
	Material	Springs steel, heat treated.		
	Pressure levers	18, integral with spring.		
Disc	Driving	Two (Flywheel and pressure plate)		
	Driven	One		
	Vibration insulation	16 cushion springs at hub.	6 cushion springs at hub.	
	Facing	Material:	Folded asbestos composition.	
	Outside diameter	9-1/8	10-3/4	
	Inside diameter	6-1/8	7	
	Area	71.64 square inches	104.6 square inches	
	Thickness	.132-.138	.137-.143	
Bearings	Throwout (Release)	Type, make, number	Special ball bearing-M.D. 809422.	
		Lubrication	Packed for life.	
	Pilot	Make and number	Chev. #12562	
		Type	Copper graphite bushing.	
		I.D.	.5915-.5925	
		O.D.	1.0935-1.0945	
		Width	.740-.760	
Lubrication	Self			
Controls	Clutch fork type	Drop-forged (pivot mounted on ball).		
	Fork mounting	On brake main cylinder.		
Flywheel	Material	Cast alloy iron.		
	Weight (with ring gear)	30 pounds		
	Ring gear type	Steel, shrunk on.		
	Ring gear teeth	135, 1/2 wide, 13.9 P.D. (9 teeth on starter pinion)		
Clutch attachment to flywheel:		6 bolts	9 bolts	

**TRANSMISSION**

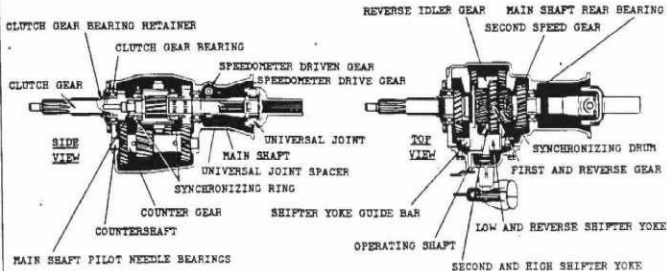

Make ----- Own  
 Location ----- In unit with engine  
 Type ----- Selective synchro-mesh  
 Heavy duty transmission ----- RPO 316A used with regular axle and RPO 316B with 3.75:1 axle, at extra cost. This transmission has countershaft roller bearings in place of bushings. Also for RPO 316B, speedometer gears are changed to maintain the same wheel to speedometer ratio.  
 Input torque capacity ----- 200 ft. lb.  
 Overdrive ----- None available  
 Power take-off ----- None  
 Actuation of shift ----- Vacuum Power Gearshift provides 80% of effort. 20% of effort retained to give driver "feel" of the gears.  
 Shifter location ----- On steering column  
 Selection of gears ----- By rod linkage  
 Meshing of gears ----- By rod and vacuum  
 Vacuum control make ----- Bendix  
 Shift pattern ----- Standard H  
 Number of speeds ----- 3 forward, 1 reverse  
 Gears type ----- All helical  
 Synchronous meshing gears ----- Second and third  
 Constant mesh gears ----- Second and third  
 Gear ratios-first ----- 2.94 to 1  
                                   -second ----- 1.66 to 1  
                                   -third ----- Direct  
                                   -reverse ----- 2.94 to 1

Speedometer gears:	Regular and RPO 316A	RPO 316B
-pitch	18.825	22.00
-teeth-drive and driven	4 and 12	5 and 14

Lubricant capacity ----- 1-1/2 pt.  
 Lubricant recommended ----- SAE 90 transmission or mineral oil lubricant.

B-1-47

**CHEVROLET 1947 SPECIFICATIONS—PASSENGER**

Clutch gear bearing:  
 -number ----- N.D. 954388  
 -type ----- Ball  
 -I.D. ----- 1.3775-1.3780  
 -O.D. ----- 2.8341-2.8346  
 -width ----- .6643-.6693

Mainshaft front bearing:  
 -type ----- 14 rollers  
 -O.D. of roller ----- .1873-.1875  
 -length of roller ----- .512-.527

Second speed gear bearing:  
 -type ----- Gear revolves directly on mainshaft  
 -I.D. of gear ----- 1.062-1.063  
 -Length of bearing in gear ----- 1-3/4

Mainshaft rear bearing:  
 -number ----- N.D. 954150  
 -type ----- Ball  
 -I.D. ----- .9839-.9843  
 -O.D. ----- 2.4404-2.4409  
 -width ----- .6643-.6693

Reverse idler bushing (front and rear):  
 -material ----- Bronze  
 -I.D. ----- .7515-.7525  
 -O.D. ----- Push fit in ring gauge .8805 Dia.  
 -length ----- 3/4

Countershaft bearing (front and rear) reg. equip.  
 -material ----- Bronze  
 -I.D. ----- .8772-.8782  
 -O.D. ----- Push fit in ring gauge 1.006 Dia.  
 -length ----- 1-1/4

Countershaft bearing (front and rear) RPO 316A and B - Heavy duty transmission.  
 -type ----- 25 rollers  
 -O.D. of roller ----- .1248-.1250  
 -length of roller ----- .735-.750

**TRANSMISSION-43**

## STEERING

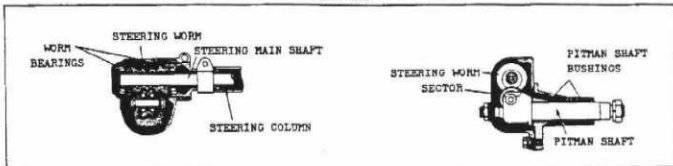

Type -- Shockproof (rubber-insulated pitman arm)

### STEERING LINKAGE AND WHEEL

Pitman arm type ----- 2-piece, rubber insulated  
 Number of tie rods ----- 2  
 Drag links or intermediate steering arms ---- None  
 Steering main shaft diameter ----- 3/4  
 Steering column diameter ----- 1-1/2  
 Steering column bearing ----- Saginaw 264887, special ball.  
 Steering wheel ----- 2-spoke, 2-tone with horn blowing ring (Fleetmaster, Fleetline and 1501 chassis) or 3-spoke with horn button (Stylemaster), 17-1/4 dia., hard rubber on steel.  
 Number of turns of steering wheel for full left to right swing of front wheels ----- 4.1

### STEERING GEAR

Make ----- Saginaw  
 Type ----- Semi-reversible, hour glass worm and ball bearing roller sector.  
 Ratio ----- 17.5:1  
 Worm and sector adjustment ---- Fully adjustable  
 Worm thrust bearing and race:  
   -bearing part number ----- Saginaw 261866  
   -bearing type ----- Tapered roller  
   -race O.D. ----- 1.7500-1.7510  
   -race width ----- .373-.377  
 Sector mounting type ----- Overhung  
 Sector roller bearing:  
   -part number ----- Saginaw 262605  
   -type ----- 2 row ball  
   -I.D. ----- .4370-.4375  
   -width ----- 1.030-1.034  
 Pitman shaft bushings:  
   -material ----- Bimetal  
   -I.D. ----- 1.125-1.126  
   -O.D. ----- 1.252-1.254  
   -width ----- 1-1/2  
 Lubricant recommended ----- All Purpose Gear Lubricant or Chassis Lubricant.

### TURNING DIAMETERS

A

Right turn -- 41 ft.  
 Left turn -- 39 ft.

B

Right turn -- 43 ft.  
 Left turn -- 41 ft.

Nominal figures based on tests made at General Motors Proving Ground.

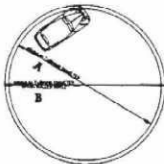

## WHEELS AND TIRES

### WHEELS

Make	Ow
Type	Short spoke disc
Attachment to hub	6, 7/16-20 bolts
Bolt circle diameter	5-1/2
Wheel offset	9/16
Wheel rim size	16 x 4.00E
Wheel paint	See Exterior Colors and Finishes

WHEEL  
AND  
HUB CAP  
DESIGN  
(ALL MODELS)



### TIRES\*

#### TIRE AND RIM ASSOCIATION STANDARDS

TIRE SIZE AND PLY RATING	REGULAR EQUIPMENT OF RPC	LOADED RADIUS ROLLED	LOADED REV. PER MILE	LOAD PER TIRE		RECOMMENDED PRESSURE		TUBE	VALVE
				FRONT	REAR	FRONT	REAR		
6.00-16-e	Regular	13.6	743	875	915	26	28	6.00	15
6.00-16-f	RPC 274E			915	955	28 9	30 9		

\* - U.S. Rubber Co. standards shown. Tires furnished are U.S., Goodrich, and Firestone.  
 9 - Sedan delivery recommended pressure, 30 front; 36 rear.

6-1-47

**LIGHTS****HEADLAMPS**

Make and type ----- Guide, Sealed Beam  
 Location ----- Streamlined in fender top  
 Sealed Beam Unit-diameter ----- 7.032 maximum  
                                     -lens diameter ----- 6-11/16  
 Dimmed by ----- Depressed beam, by foot switch  
 Beam indicator location ---- On instrument panel

**REAR LICENSE LAMP**

Location ----- In cluster with trunk door handle, below license plate.

**OTHER LAMPS**

Dome lamp (all models) also serves as reading lamp  
 Courtesy light (on floor) ----- None  
 Trunk compartment light ----- Window in right hand tail light.

**PARKING LAMPS**

Location ----- At extreme outer ends of radiator grille two lower bars.

**TAIL AND STOP LAMPS**

Make and type ----- Guide, combined in one unit  
 Number and location ----- 2 on deck side panels, except one in center of Sedan  
 Delivery rear door and one on left of Station Wagon body.

NOTE: Station Wagon and Sedan Delivery rear license plate is illuminated by tail lamp.

Are tail and instrument cluster lamps wired in series ----- No

**LIGHTING SWITCHES**

Make ----- Delco-Remy  
 Location of main switch ---- On instrument panel  
 Main switch may be rotated to vary intensity or turn off instrument panel lights.  
 Stop lamp switch ----- Mechanical, on toe board  
 Dome lamp switch, manual ----- In right door pillar of all models, except Station Wagon (at lamp) and Cabriolet (at side of rear seat).  
 Dome lamp switch, automatic ----- By opening left front door, except Stylemaster models.  
 Glove compartment light switch, automatic --- By opening door on Fleetline and Fleetmaster.

**BULBS and FUSE**

Used in	Quantity	Size	C.P.	Used in	Quantity	Size	C.P.
Parking lamp (each)	1	#63	3	Tail lamp (each)	1	#1154*	3
Instrument cluster	2	#55	2	(Stn. Wagon & Sed. Dely.)	1	# 63	3
Speedometer	2	#55	2	Stop lamp (each)	1	#1154*	21
Headlamp beam indicator	1	#51	1	(Stn. Wagon & Sed. Dely.)	1	# 87	15
Ignition lock	1	#51	1	License plate lamp	1	# 63	3
Glove compartment	1	#55	2	Headlamp (each)-----	2	filaments in Sealed Beam Unit ----- upper beam 45 watts lower beam 35 watts	
Clock	1	#55	2	* Double filament bulb in combined tail and stop lamp.			
Dome Station Wagon lamp	1	#51	6				
Cabriolet	1	#55	2				
All others	1	#52	6				
Fuse - 30 ampere, glass encased SFE cartridge mounted on main light switch							

**HORNS**

Make ----- Delco-Remy  
 Type ----- Vibrator  
 Number used ----- 2, behind radiator grille  
 Relay in circuit ----- Yes  
 Amperage draw-high note ----- 17 to 19  
   -low note ----- 19 to 21

**TOOL KIT**

Jack-capacity ----- 1200 lb.  
     -raised height ----- 29  
     -lowered height ----- 6-3/8  
 Jack handle ----- Yes  
 Spare tire lock ----- Station Wagon only  
 Tire changing iron ----- None  
 Starting crank ----- Service part  
 Starting crank bracket ----- Yes  
 Wrenches ----- 3 open end, spark plug, and wheel.  
 Screw driver ----- 6 inch round shank  
 Pliers ----- 6 inch combination  
 Hammer ----- 10 ounce ball peen type  
 Tool bag material ----- Cotton duck

**CHASSIS GENERAL INFORMATION**

Chassis lubrication ----- High pressure gun  
 Total anti-friction bearings ----- 22