



# THE NEW FORD



IS THE PRODUCT  
OF TWENTY NINE  
YEARS EXPERIENCE  
IN BUILDING OVER  
TWENTY MILLION  
AUTOMOBILES

*It represents an  
outstanding value in  
motorcar history*

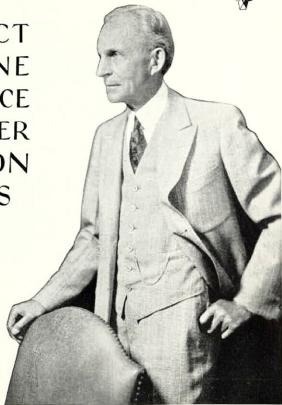

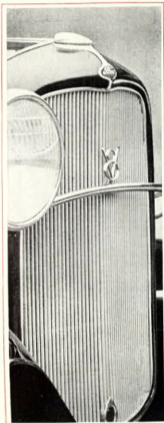

# *Modern Beauty*

*as distinguished in Appearance  
as in Performance*



Low Sweeping Design

Smart Fenders

Wide Rubber-covered  
Running Boards

Luxurious Interiors

Rounded, Slanting  
Windshield

Distinctive Hardware

Convenient and Attractive  
Instrument Panel

---

BEAUTY



# ENDURING BEAUTY

*Permanent Pride of Ownership*

7 Coats insure  
Lasting  
Finish

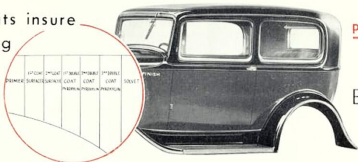

PYROXYLIN FINISH

Baked Enamel  
Fenders



Enduring beauty of Ford cars is further  
insured by protection against rust . . .

RUSTLESS STEEL

BONDERITE

will not  
RUST  
TARNISH  
or  
STAIN

Fender finish  
protected from  
rust spreading  
if scratched



BEAUTY



# DRAWING ROOM LUXURY

*For Driver and Passengers*



*Distinctive De Luxe Appointments*

## EVERY DRIVING CONVENIENCE

Conveniently Located Starter Button, Clear View Instrument Panel, Coincidental Steering and Ignition Lock, Automatic Spark Control, Clear Vision through 10 Degree Slanting Windshield, Inside Adjustable Sun Visors



BEAUTY



# True Streamline Design

*Body Lines Blend Throughout*



From bumper to bumper the new Ford presents perfect coordination of body curves and lines accentuating the low, streamline effect

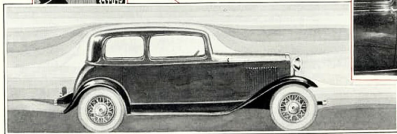

Rounded Lines provide minimum Air Resistance

BEAUTY

# THE THRILL OF EIGHT CYLINDERS

*The smooth, powerful Ford V-8  
puts a new joy in motoring*

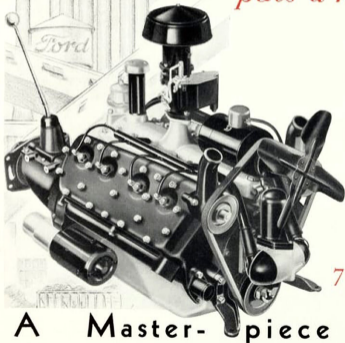

AN ENGINE with world's of power to spare that by the very brilliance of its performance, new principles of design and construction will prove to you what advanced motor design can mean.

V-Type 65 h.p. Motor  
*75 m.p.h. in high*

**A Master-piece of Simplicity**

PERFORMANCE



# TROUBLE PROOF IGNITION SYSTEM

AIR COOLED

*Extreme Forward  
Position*

of generator and  
ignition coil protects  
these units from  
engine heat

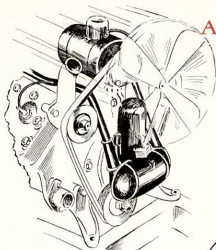

NO GEARS TO  
THROW TIMING OFF



*Waterproof  
Against short circuit*

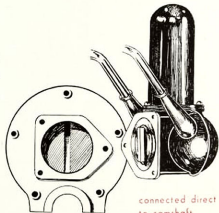

*connected direct  
to camshaft*

## SIMPLICITY BRINGS DEPENDABILITY

PERFORMANCE



# AUTOMATIC SPARK CONTROL

*It Acts for You*

## Vacuum Control

The same vacuum force that operates your windshield wiper also retards ignition spark

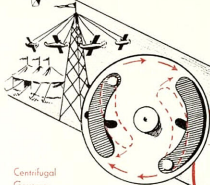

Centrifugal Governor

Governor weights spread as speed increases thereby advancing spark

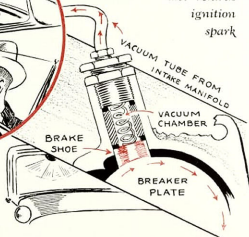
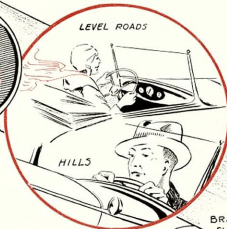

One Less Operation  
While Driving

Lightning Pick-up at Six or Sixty!

PERFORMANCE





# SHORT, RIGID CRANKSHAFT

Integral Counter Weights



*Statically and Dynamically Balanced*

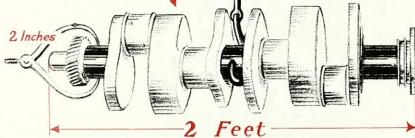

*Circular tongue and groove in main bearing cap and crankcase prevent strain on main bearing bolts*

PERFECT BALANCE—NO WHIPPING—BEARING LOAD REDUCED TO A MINIMUM

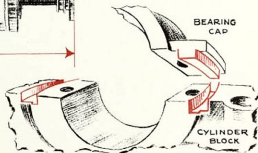

Torsional Vibration Eliminated by Rigid Construction

PERFORMANCE



# EXTRA LONG LIFE OF BEARINGS IN CONNECTING RODS

Babbitt Coated  
Steel Bushing  
full width  
of Crankpin  
Bearing  
distributes  
pressure over  
area twice the  
width of  
Connecting  
Rod

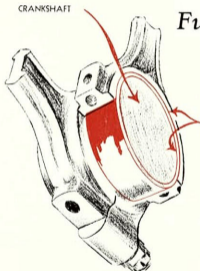

results from using  
Full Floating Bushings

Double Oil Film  
giving Double  
Lubrication

An Exclusive Ford  
Feature

Result—

Greater Economy Through Reduced **Wear**  
PERFORMANCE



# SECURELY CUSHIONED

*in Live Rubber*

SMOOTHNESS

Complete live rubber insulation with the advantage of 3 point suspension

ENGINE FREE TO MOVE

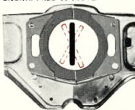

Rubber Collar  
Rear Mounting

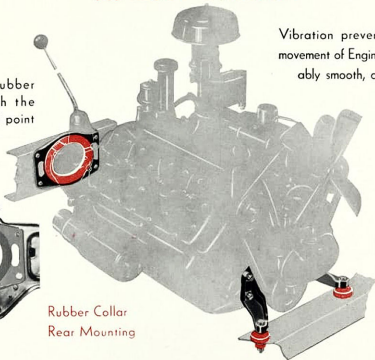

Vibration prevented by controlled movement of Engine resulting in remarkably smooth, quiet performance

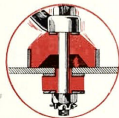

Rubber Cushions  
Front Mounting

---

PERFORMANCE



# POSITIVE LUBRICATION AT ANY SPEED

*Pressure and spray distributes  
oil to all moving parts*



*Oil sprayed under pressure lubricates wrist-pin bearings.*

Oil is pumped to distributing line and from there to camshaft bearings and crankshaft main bearings through leads to connecting rod

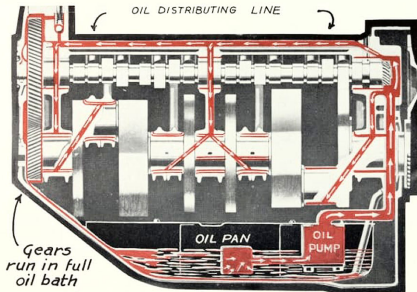

PERFORMANCE



# DOUBLE-PUMP COOLING SYSTEM

Safe—Under the  
Most Trying  
Conditions



A Wall of Water  
encloses each  
cylinder

Valve Seats are also  
protected, preventing  
valve distortion

PERFORMANCE



# FORD SAFETY

*Modern day traffic and general high speed demand that you have permanent safety in your car*



*Ford Safety Factors give You that Protection*

1. Steel Safety Body
2. Safety Plate Glass
3. Positive Mechanical Brakes
4. Torque Tube and Radius Rods  
Correct Brake Alignment
5. Flexible Transverse Springs
6. Automatic Ride Control
7. Double Drop Frame  
Low Center of Gravity
8. Narrow Front Pillars
9. Welded Gas Tank
10. Welded Steel Spoke Wheels
11. Semi-reversible Steering



# SAFETY-GLASS GIVES CONSTANT PROTECTION

## Standard Equipment—

All Ford Cars have Safety-Glass  
Windshields—De Luxe Models  
equipped throughout with  
Safety-Glass

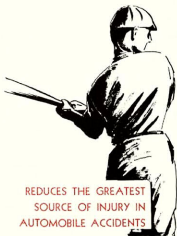

REDUCES THE GREATEST  
SOURCE OF INJURY IN  
AUTOMOBILE ACCIDENTS

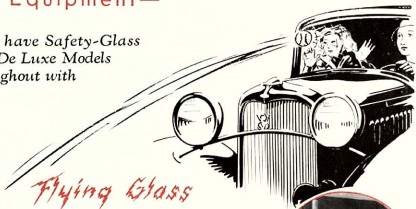

### *Flying Glass*

has turned many a  
minor accident into grim  
catastrophe. Consideration  
for your family, your friends  
and yourself demands this  
constant protection



Let Safety-Glass Increase Your Motoring Pleasures

SAFETY



# HIGH SPEED WITH SAFETY

*Due to Low Center of Gravity*

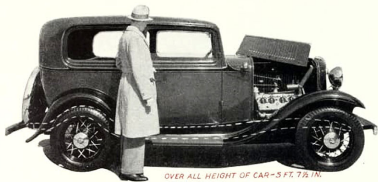

OVER ALL HEIGHT OF CAR—5 FT. 7 1/2 IN.

## *Double Drop Frame*

gives deep, long and wide support to the body which is mounted direct to the frame. Low, flat springs give a feeling of complete security



Makes Possible Low Sweeping Design

SAFETY





# SURE STOPPING!

Powerful Brakes  
to meet the New Standards  
of Speed and Power



*SPLIT-SECOND SAFETY*

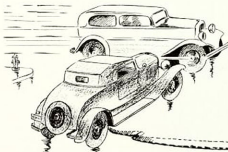

LONG LIFE DRUMS  
of Special Cast Alloy Iron  
minimizing SCORING

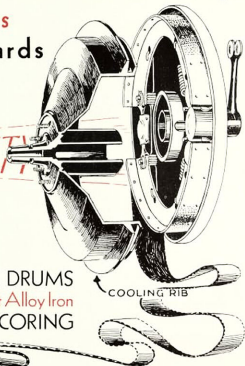

COOLING RIB

186 Square Inches of Braking Surface

SAFETY



# SAFETY IN FORD STEEL BODIES

*Greater Strength to  
meet increased  
power and speed*

BUILT IN INSULATED  
RADIO AERIAL

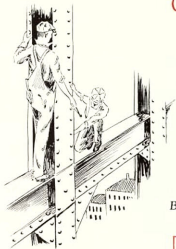
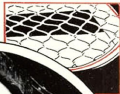

SKYSCRAPER STRENGTH  
With welded joints  
Steel reinforcing  
and Beaded Panels

STEEL

*Braced with steel*

BUILT LIKE A  
STEEL RAILWAY COACH

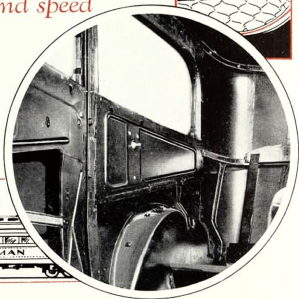

Modern Traffic Demands STEEL Body Safety - - -  
SAFETY

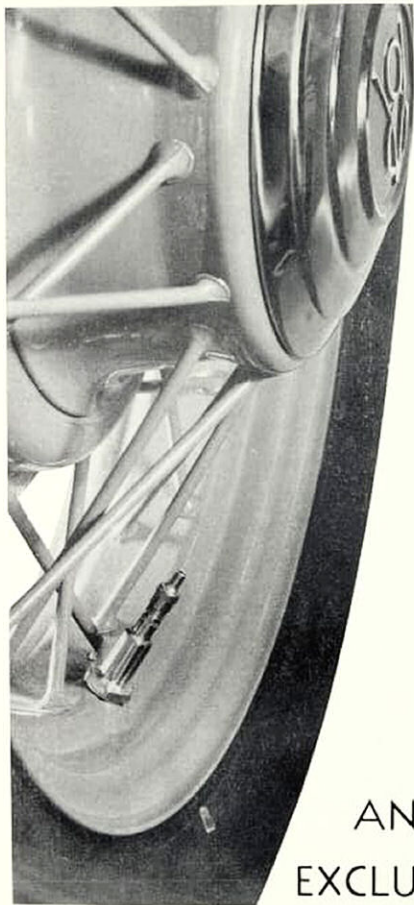

# ONE PIECE STRENGTH

## *Ford Steel Spoke Wheels*



ELECTRICALLY WELDED INTO ONE PIECE

*Road shocks equally distributed  
to all spokes*

EACH SPOKE WILL  
WITHSTAND A STRAIN  
OF 4000 POUNDS

*Small wheels with large hubs  
meet the modern standard of  
beauty . . . Large tires give  
increased riding comfort*



AN  
EXCLUSIVE FORD FEATURE

SAFETY

# *Luxurious Riding Comfort in the New Ford*

## COMFORT FEATURES

Live Rubber Suspension  
of Body and Frame  
*Freedom from Road Shock*

Roomy Bodies—  
Generous seating, head  
and leg room

113½ in. Springbase—  
*Utmost in Comfort with  
short turning radius*

Double Drop Frame—  
*Low center of gravity—  
Greater safety*

Transverse Springs—  
*New low, flexible rear  
spring—  
Roadability*

Automatic Ride Control  
*It thinks for You*

Effortless Steering



---

COMFORT



# AUTOMATIC RIDE-CONTROL

*It thinks for itself*

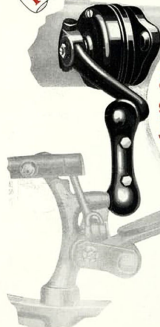

*at any speed  
on any road  
at any temperature*

Houdaille Automatic,  
Double-Acting,  
Shock-Absorbers  
give smooth riding

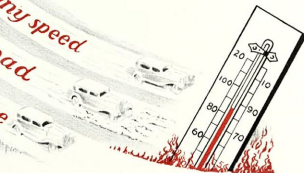

Thermostatic Temperature Adjustment  
Automatic Road Adjustment

COMFORT



# UTMOST IN RIDING COMFORT

*Assured by 113½" Springbase*

Springbase, not wheelbase,  
Gives riding comfort

Rear spring mounted behind axle  
makes longer body possible without  
sacrificing flexibility in handling

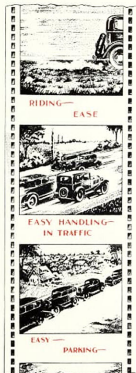
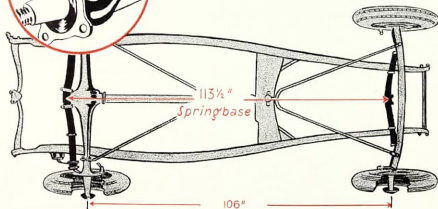
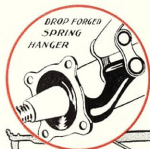

Smooth, Balanced Roadability

COMFORT



# PERFECT RIDING EASE AT ANY SPEED

*with Transverse Spring Suspension*

Body Stays Level

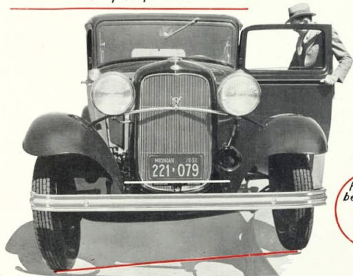

Side-sway and body-twisting eliminated

Wheels play up and down without affecting level of body . . . .

LOW UNSPRUNG WEIGHT  
LESS WEIGHT UNDER SPRINGS

*flexibility  
below weight*



No spring weight to increase force of road shocks

COMFORT



# QUIET, EFFORTLESS GEAR SHIFTING

## *Fully Synchronized*

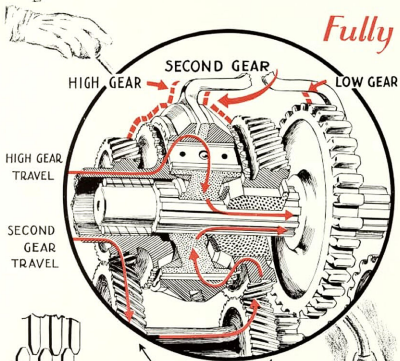

Helical Cut Gears  
in constant mesh  
provide Silent Second

### SYNCHRONIZING DEVICE —

In shifting to either second or high, synchronizing device moves as a unit until hub contacts gear flange. With this device acting as a clutch the speed of both are made uniform eliminating all clashing.

COMFORT

Tapered ends permit easy, noiseless shifting





# SMOOTH QUIET RIDING COMFORT

Truly complete insulation of running gear from frame gives you riding ease and effortless control

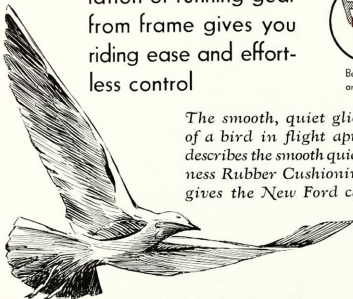

*The smooth, quiet glide of a bird in flight aptly describes the smooth quietness Rubber Cushioning gives the New Ford car*

## RUBBER CUSHIONED



Between Body and Frame



Spring Shackles



Torque Tube Universal End



Ball Socket of front Radius Rods



Shock Absorber Links

# NO METAL-TO-METAL CONTACT

COMFORT

TUDOR  SEDAN

De Luxe Appointments

Dome Light    Cowl Lamps  
Rear Seat Arm Rests  
Assist Cards    Ash Trays  
Tapestry Carpets Throughout  
Safety Glass Throughout.

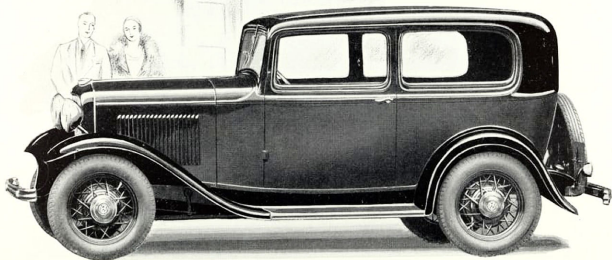

BEAUTY



De Luxe Appointments

- Assist Cords
- Ash Trays
- Luggage compartment behind rear seat
- Dome Light
- Cowl Lamps
- Rear Seat Arm Rests
- Safety Glass Throughout

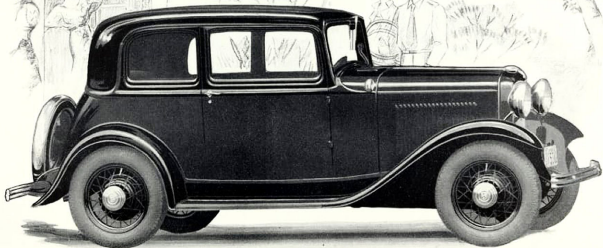

BEAUTY



Top may be raised or lowered without getting out of car. Safety glass in rear window. Genuine Leather, Bedford Card upholstery. Safety Glass Throughout

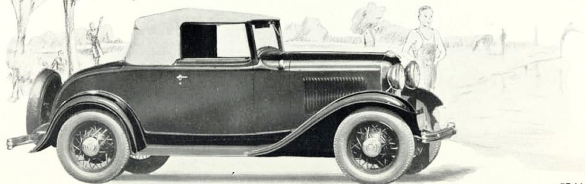
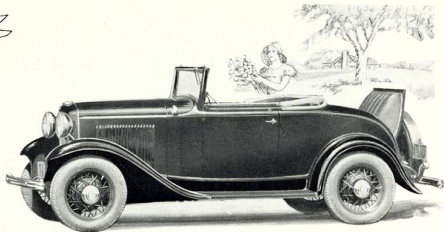

BEAUTY

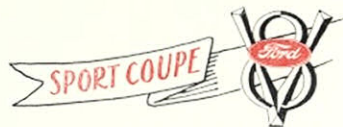
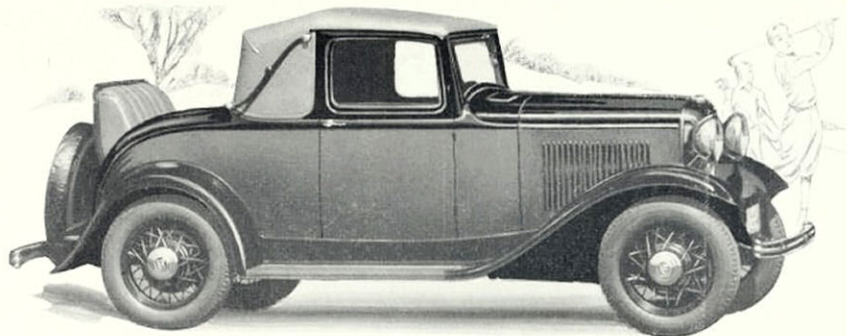

Has soft waterproof light brown  
landau grain top  
Rumble seat standard

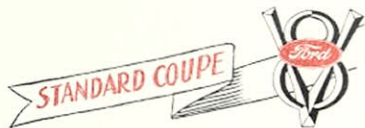
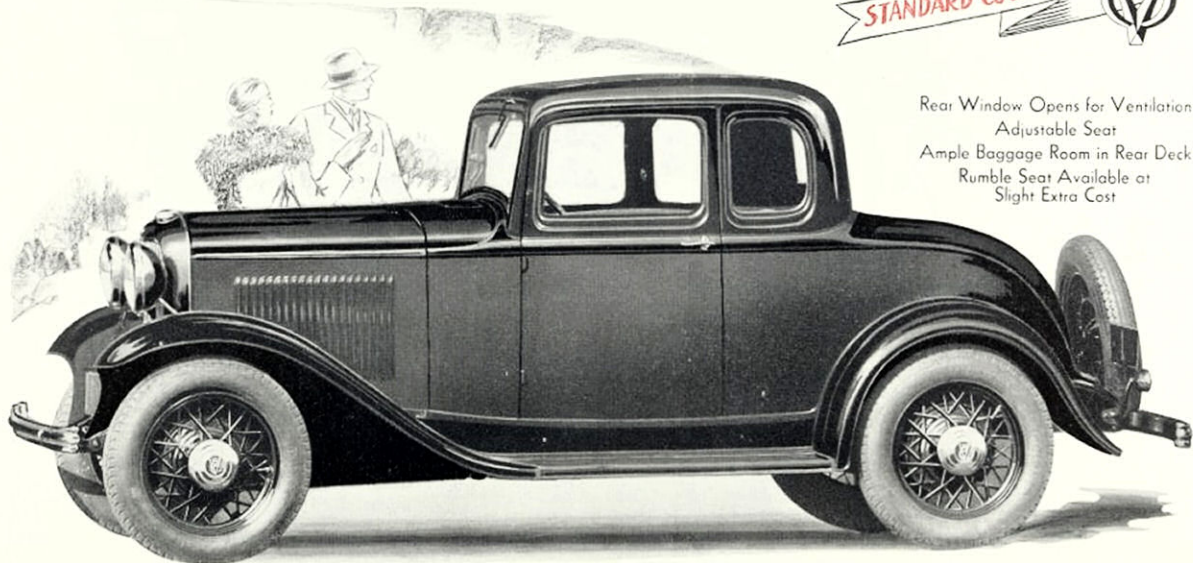

Rear Window Opens for Ventilation  
Adjustable Seat  
Ample Baggage Room in Rear Deck  
Rumble Seat Available at  
Slight Extra Cost

BEAUTY



**De Luxe Appointments**

Front Seat Upholstered in Genuine  
Leather

Windshield Wings of Safety Glass

Safety Glass Rear Window

Rumble Seat Cowl Lights



**De Luxe Appointments**

Genuine Leather Upholstery  
Side Windshield Wings of Safety Glass  
Safety Glass Rear Window  
Cowl Lights

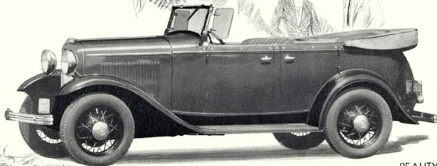

**BEAUTY**

CONVERTIBLE  SEDAN

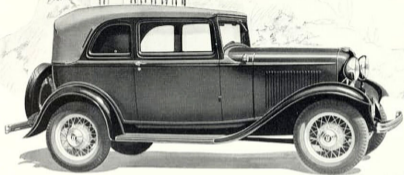

Top may be easily raised or lowered. Safety glass throughout. Seats trimmed in genuine leather of Russet Brown color.

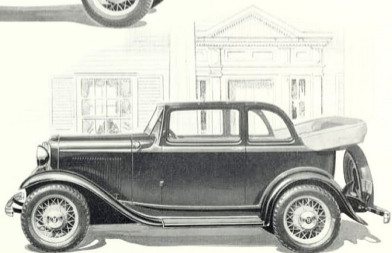

BEAUTY

# INDIVIDUALIZING THE FORD CAR

With Well Chosen Accessories

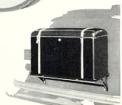
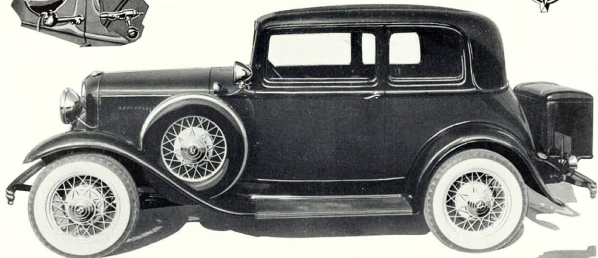
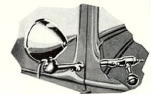

BEAUTY





# FRICION REDUCED-POWER INCREASED

*Each Ford Bearing is selected  
to best carry its load strain*

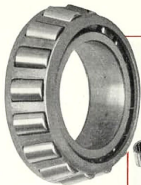

TAPER ROLLER  
BEARING

In front wheels  
take up end  
thrust

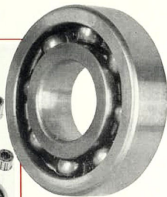
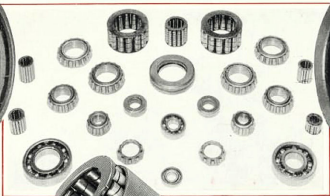

BALL  
BEARING

Used only for light  
radial loads

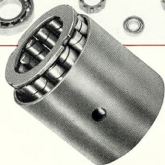

SPIRAL ROLLER  
BEARING

On rear wheels  
have large surface  
for heavy loads

## Total of 24 Anti-Friction Bearings

EXTRA VALUE



# LONGER LIFE - GREATER EFFICIENCY

*In 3/4 Floating Rear Axle*

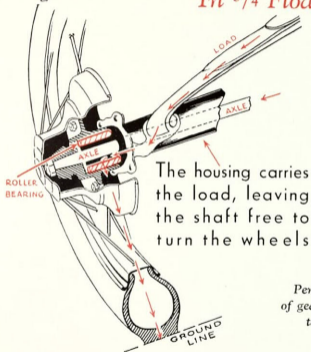

The housing carries the load, leaving the shaft free to turn the wheels

*The only duty of the axle shaft is to turn the wheels*

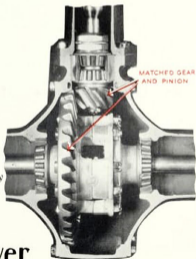

Perfect alignment of gears is assured by tapered roller bearings

## Load Free Axle Increases Road-Power

EXTRA VALUE



# NO ABNORMAL STRAIN ON SPRINGS

*with Torque Tube and Radius Rods*

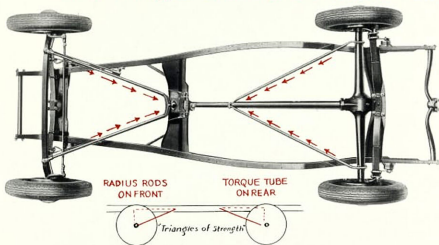

Springs not hampered by driving force or braking strain . . . axle always in perfect alignment.

Springs Have Free Play To Absorb Road Shocks

EXTRA VALUE



# MAXIMUM STRENGTH

*with minimum weight*

## Drop Forgings

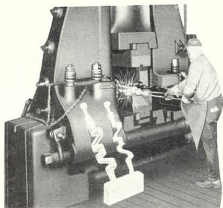

Drop Forgings embody light-weight with great strength

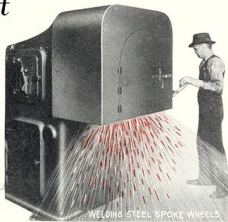

## One Piece Strength



Electric welding fuses two pieces into one

## Electric Weldings

EXTRA VALUE



# MORE RESPONSIVE PERFORMANCE

*with Aluminum Pistons*

*Pistons must stop and start at  
top and bottom of each stroke.  
With light-weight pistons  
this requires less power*

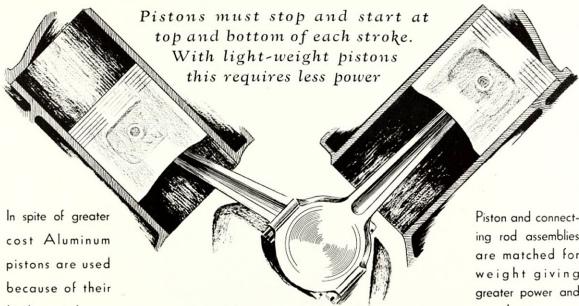

In spite of greater cost Aluminum pistons are used because of their Light weight . . .

Piston and connecting rod assemblies are matched for weight giving greater power and smoothness . . . .

Reduces Crankshaft Strain and Vibration

EXTRA VALUE



# ENJOY THE DISTINCT ADVANTAGES OF AUTHORIZED FORD SERVICE

## LUBRICATION AND INSPECTION SERVICE FOR ONE YEAR

(Or for the first 12000 Miles)

Lubrication Inspection and adjustment  
(No charge except for engine oil)

At end of 300 miles and 1000 miles

Thereafter—

We will without any further charge  
Lubricate Chassis fittings once each  
month for eleven months or once  
each 1000 miles for first 12000 miles  
whichever occurs first

**FREE  
INSPECTION  
AT ANY TIME**



*A sale does not complete the transaction  
between us and the buyer but establishes  
a new obligation on us to see that his car  
gives him satisfactory service*

—HENRY FORD

*Our Customers' satisfaction  
is our first interest*





# IT IS EASY TO OWN A NEW FORD

through *Authorized Ford Finance Plans*  
of *Universal Credit Company*



Small Down Payment

Low Monthly Payments

Protection against Fire and Theft  
during period of contract

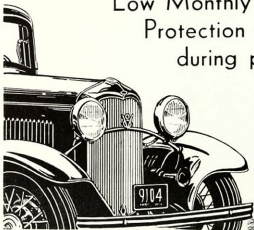

You can easily bridge the gap  
with convenient small monthly  
payments



## Ford Finance U.C.C. Plans Are Economical