

*1960 taxicabs  
by Chevrolet*





profit-proved  
**low cost and upkeep**

Chevrolet, America's most popular car, is also a favorite taxicab. The reasons are many, but most important to taxicab owners are the low initial cost, low upkeep, and high resale value. Chevy's 1960 taxicabs are more ruggedly built than ever with an even sturdier Safety-Girder frame and stronger Body by Fisher. Economy-minded Hi-Thrift 6 and new Economy Turbo-Fire V8 take you more miles on your gasoline and oil dollar. And when Chevrolets are sold, they bring much more.

1 functional front-end styling in Biscayne 4-Door Sedan

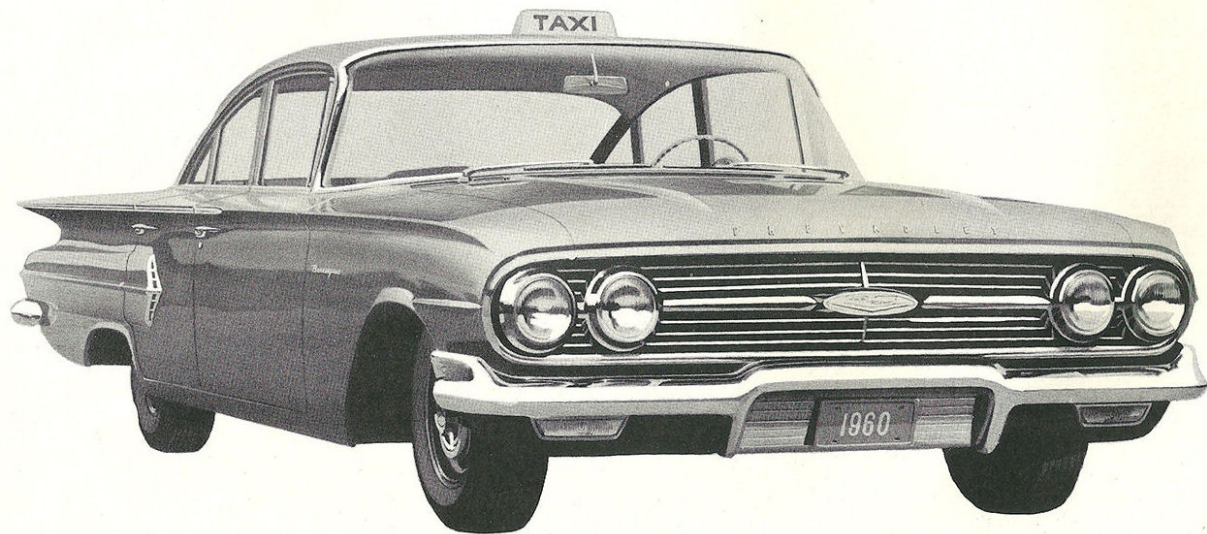

1  
Up front, Chevrolet's rugged bumper is mounted high and extends completely around each fender corner for maximum protection. The bumper shields both the license plate and the combination parking and directional lights against damage. New anodized aluminum grille can't rust . . . stays good looking for life. And Chevy's High-Level ventilation intake extends nearly the full width of cowl for high volume air flow.

2  
Rear styling of '60 Chevy taxicabs is both smart looking and functional. A high wrap-around bumper protects sides as well as rear. Dual-unit taillights use a separate bulb in each unit for extra-safe night driving. Of great importance to the hurried taxicab operator, there's new loading convenience in Chevy's giant luggage compartment . . . trunk sill is lower, yet high enough to keep luggage snugly in place.

passenger-proved  
**comfort and convenience**



Passengers in new Chevrolet taxicabs are treated to real comfort. Big, wide-opening doors make entry and exit easy. Deep-cushioned seats give a luxury ride to every mile. And generous head room, leg room, and shoulder room offer spaciousness to spare even for a cabload of adults. Chevy's huge, clear expanses of Safety Plate Glass let passengers enjoy a sightseeing tour in every trip. There's a relaxing new hushed silence in the 1960 taxi ride, too, thanks to new larger and thicker body mounts.

smart new going-away view in Biscayne 4-Door Sedan 2

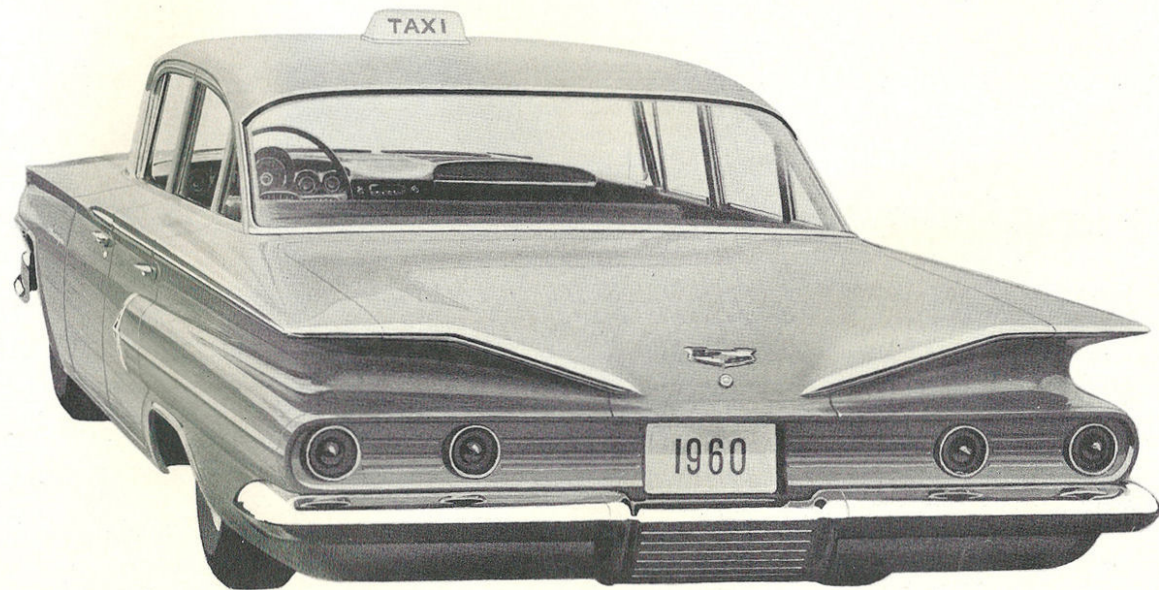

# 20 special custom-engineered features for Chevrolet factory-built taxicabs... r.p.o. 330



## 15" wheels and Tyrex cord tires

Special taxi-size 15 x 5K wheels accommodate 6.70 x 15 4-ply rating Tyrex cord tires that, like the standard tires, are improved for '60 to ride better and last longer.

## longer wear front suspension

High-capacity tapered roller bearings, metallic spherical-joint liners, and heavy-duty steering knuckles give longer service and minimize maintenance.

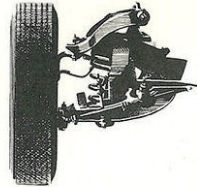

## open-door warning light

Red light on lower edge of instrument panel warns driver when any door is open—an important safety feature for taxi operators.

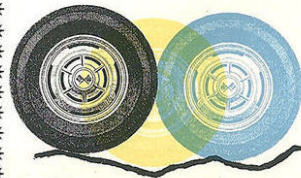
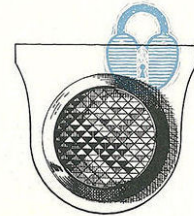

## heavy-duty suspension bushings

Special bushings in both front and rear suspension lower control arms are made of harder rubber for longer life and increased stability.

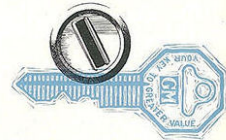

## special ignition-starter switch

Accessory position allows operation of electrical equipment with ignition off. Switch can be locked and key removed only in OFF position.

## heavy-duty shock absorbers

Special valving increases shock absorber effectiveness at all four wheels. Ride is more stable for greater passenger comfort whatever the road surface.

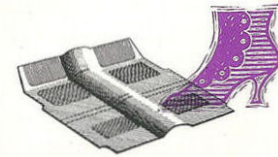

## heavy-duty front and rear floor mats

Thick black rubber mats are reinforced at accelerator pedal. Asphalt-impregnated insulation under front and rear mats prevents water-soaking.

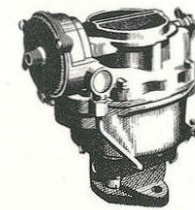

## special taxicab carburetor

Special economy carburetor with modified metering jet and smaller venturi is engineered for even more miles per gallon in taxicab operation.

## heavy-duty front seat

Reinforced heavy-gauge S-wire springs in both seat cushion and backrest make the front seat more durable to withstand rugged service.

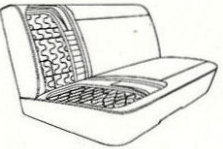

## heavy-duty rear axle

Even greater dependability is given to Chevy's traditionally rugged axle from a heavy-duty upper control arm bracket and special high-capacity roller-type rear wheel bearings.

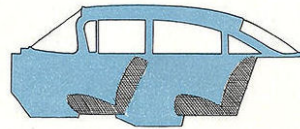

## choice of interior trim

Cloth and vinyl interior standard in R.P.O. 330. Special durable all-vinyl available at slight extra cost. Both interiors are attractively styled in 2-tone gray.

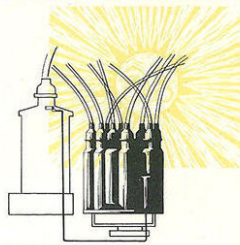

## heavy-traffic spark plugs (6-cyl. engine)

Hotter spark plugs (AC-46) give more dependable firing in traffic. In addition, a special distributor ground wire contributes to better idling.

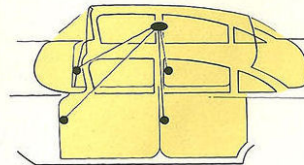

## automatic light switches

Whenever any door is opened, switch on pillar of each door turns on the interior light. Main light switch also operates the dome light.

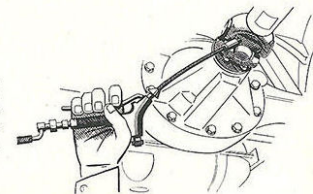

## driveshaft lubrication fittings

Pressure lubrication fittings at front, intermediate, and rear universal joints eliminate necessity of disassembly for lubrication.

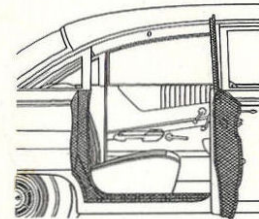

## wider opening rear doors

Special hinges allow rear doors to open 16° wider for even easier entrance and exit. Door checks hold doors in full-open position for convenience.

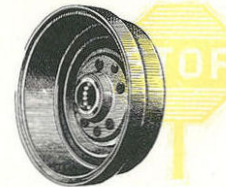

## heavy-duty brake drums

Extra-heavy brake drum webs and wheel hubs contribute to greater brake durability in stop-and-go taxicab service.



## rear door armrests

Door-pull armrests on rear doors make door closing easier, riding more comfortable, help passengers in and out.

## heavy-duty clutch and transmission (6-cyl. engine)

Extra-size 11" semi-centrifugal diaphragm spring type clutch gives extra taxicab savings by minimizing costly downtime. Heavy-duty clutch gear and mainshaft bearings increase transmission durability.

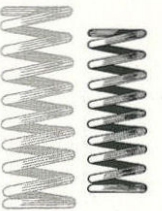

## heavy-duty springs

Super-tough coil springs at all four wheels help stabilize ride and extend durability in street-pounding taxi duty.

more go to the gallon with

## **Hi-Thrift 6**

Chevrolet's economy-designed and performance-proved taxicab engine

... the thriftiest 6 in its class

You save in many ways with Chevrolet's new Hi-Thrift 6. It offers record-breaking fuel economy, low upkeep, and top reliability. Couple these with its lively performance, and it's clear why the '60 Hi-Thrift 6 is such a popular taxicab engine. Valve timing and carburetor calibration are engineered to deliver exceptional operating economy, top torque, and excellent around-the-town responsiveness. The economy-contoured camshaft is designed to keep valves closed longer for peak efficiency during low-speed and engine idling conditions. Compression ratio of 8.25:1 and efficient wedge-shape combustion chambers get the most out of low-cost regular fuel. Smooth, quiet operation and minimum maintenance stem from Chevrolet's list of quality features found in no other six—hydraulic valve lifters . . . positive-shift starter . . . and automatic choke, to name just a few. For an even greater measure of gasoline economy, a special taxicab carburetor is included in R.P.O. 330\*.

\*Optional at extra cost.

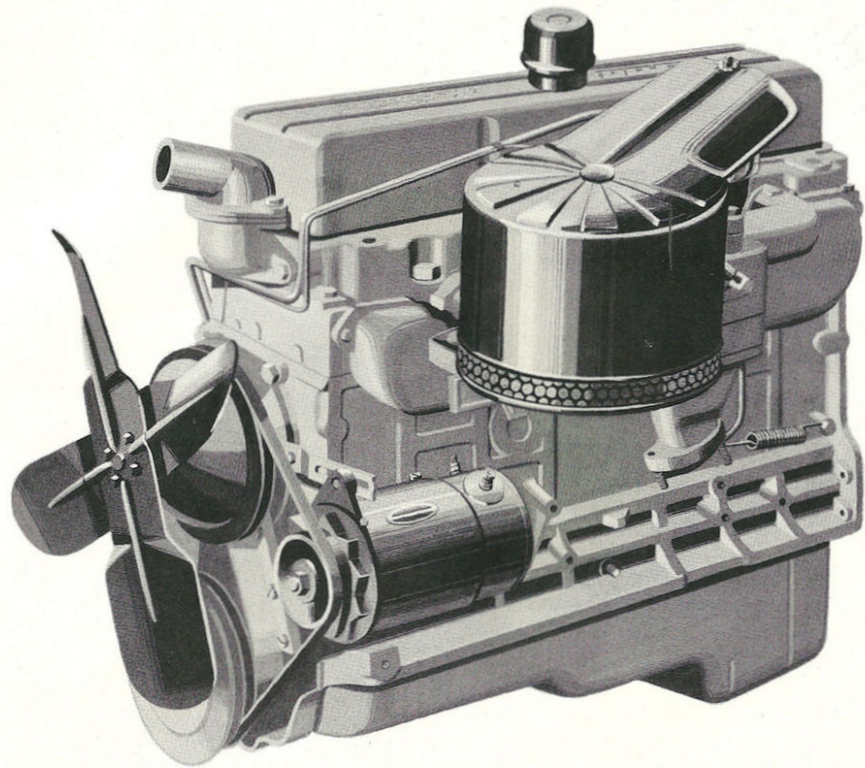

for rugged stop-and-go duty

## **taxicab-proved transmissions**

### **3-Speed Synchro-Mesh**

Quiet operation and dependability are featured in Chevrolet's rugged standard transmission. All gears are helical-type, hardened and shot-peened for maximum durability. Linkage is specially cushioned from the driveline to help isolate vibration. Gear ratios are matched to either 6 or V8 for the best combination of performance and economy. Extra heavy-duty clutch and transmission components are included in R.P.O. 330\*.

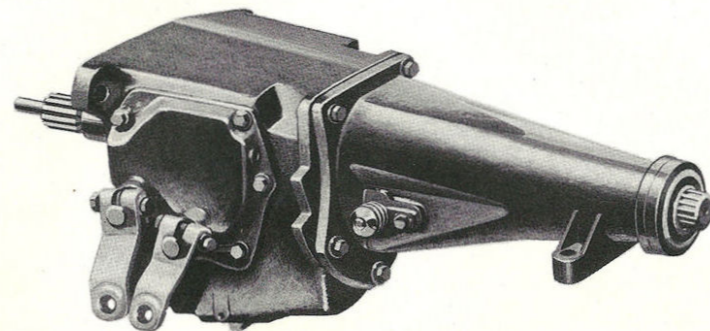

### **Powerglide\***

Powerglide's low initial cost and billion-mile-proved dependability add up to a very small per-mile cost. Drivers like the extra convenience and smoothness that make every trip seem shorter. Passengers, too, enjoy the luxury of a smooth ride even in heavy traffic. Many taxicab operators find that Powerglide pays for itself in lower driveline maintenance costs. An accelerator-controlled downshift gives the driver quick extra power when needed. For extra safety, there's a positive parking lock.

\*Optional at extra cost.

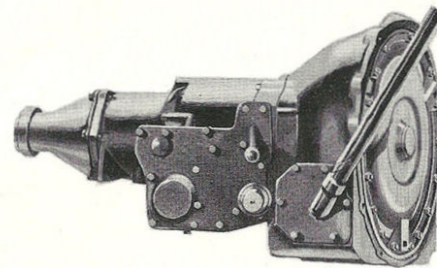

## **Economy Turbo-Fire V8**

Chevrolet's '60 Economy Turbo-Fire V8 gets up to 10% more miles out of a gallon of regular gasoline while delivering greater engine torque at normal speeds. These benefits result from a new camshaft and re-calibrated carburetion. In addition, Chevy's modified cylinder head design for 1960 contributes to even greater oil mileage. The Economy Turbo-Fire V8's low-friction, short-stroke design is especially durable in rigorous taxicab service.

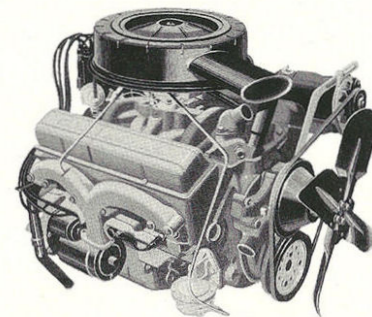

## roominess and utility

Chevrolet's functional style allows extra room for driver and passengers. Wide, deeply cushioned seats offer stretch-out comfort during the longest suburban trip. Ample head room, leg room, hip and shoulder room afford plenty of space for even your tall customers. Chevy's deep, roomy trunk features a wide, lower sill for easier loading and unloading.

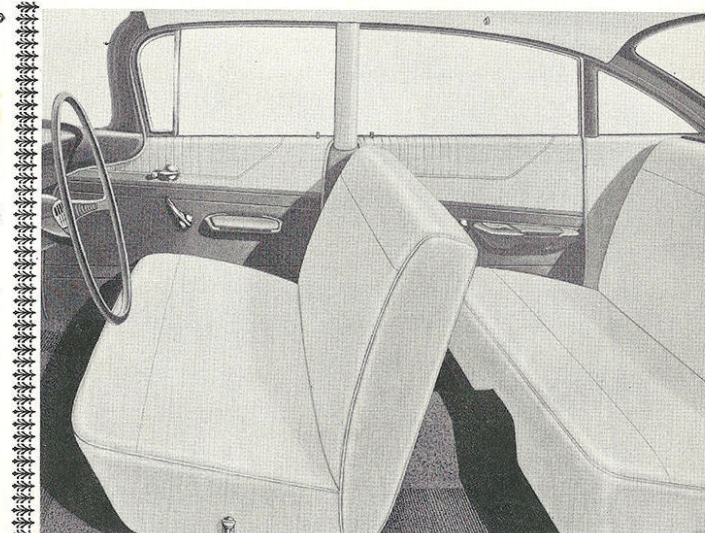
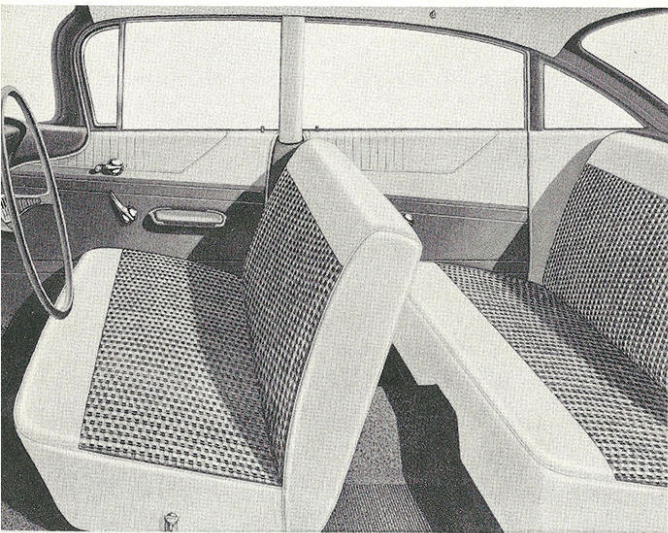

**standard Biscayne interior**—Chevrolet taxicab seats are upholstered in nylon-faced pattern cloth, with leather-grain vinyl around the edges to resist wear. Sidewall trim is leather-grain vinyl that cleans up in a hurry. Special water-resistant floor mats are included in R.P.O. 330\*.

**all-vinyl interior trim**—An all-vinyl interior is optional at slight extra cost with R.P.O. 330. All-vinyl seat upholstery, sidewall trim and headlining offer the maximum in serviceability for rugged taxicab operation. Surfaces have exceptional resistance to soiling—clean up quickly and easily.

\*Optional at extra cost.

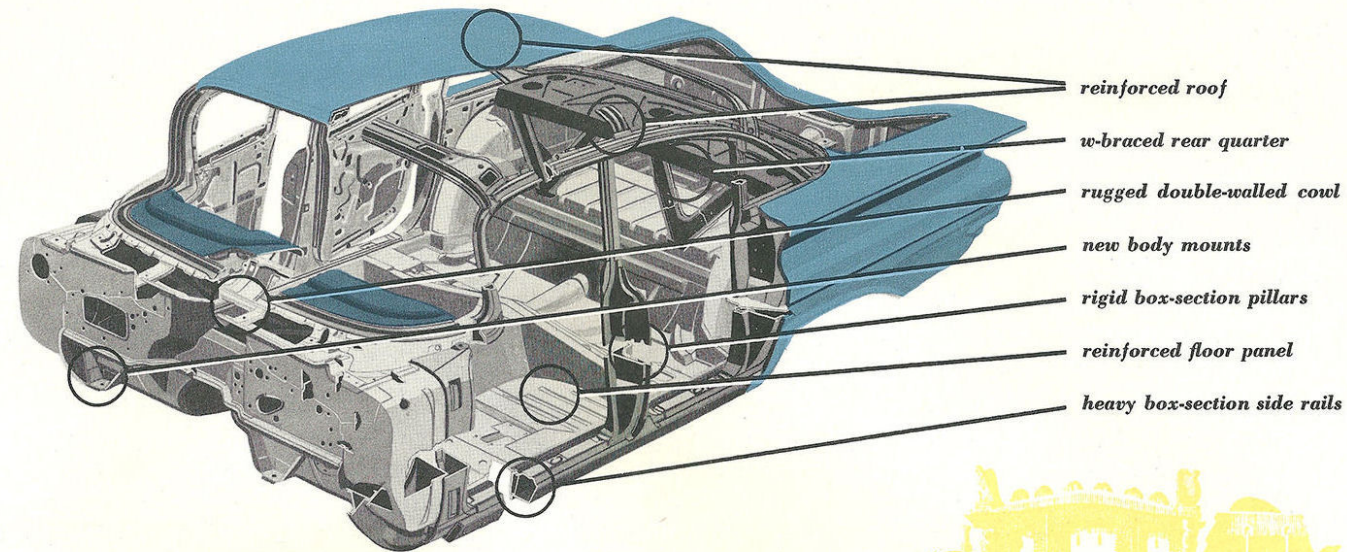

no other low-cost taxicab offers

## quality and safety of Body by Fisher

### new hushed silence

Every '60 Chevy taxicab features new body mounts that more effectively isolate road shock and noise for new hushed silence inside the car. The body mounts are larger, of new material, and positioned in a pattern that improves body cushioning. Full insulation and sound deadening materials are bonded to all major body panels for quiet comfort.

### outstanding visibility

There's almost 35 square feet of glass in every '60 Chevy taxicab, with 12 square feet in the Vista-Panoramic windshield alone. Extra slim

pillars of strong box-section design plus Safety Plate Glass throughout permit outstanding all-around viewing. All four fenders are clearly visible to the driver for easy parking and maneuvering.

### crank-operated ventipanes

This Chevrolet quality feature usually is found only in much higher priced cars. These convenient ventipanes open effortlessly and stay put where positioned.

### safety-type door latches

They hold doors securely closed and prevent latch disengagement in any direction. Chevy's high-



security one-key locking system, with quick, keyless locking of all doors from outside, combines convenience with maximum protection.

### Magic-Mirror finish

Deep-luster acrylic lacquer resists weathering and staining—keeps '60 Chevy taxicabs looking new far longer. Special primer is highly resistant to chipping and abrasion from road grit or gravel.

### hooded instruments and dual sun visors

Both offer glare-reducing safety for taxicab operator. Instruments include temperature and fuel gauges, generator and oil pressure lights, and directional signal indicator lights.

there's superior engineering in

## Chevrolet's stamina-built chassis

Chevy's rugged chassis is built with extra strength and stability for the toughest taxicab service. Reserve stopping power and crisp, precise handling offer greater safety in every trip. Important frame modifications in 1960 contribute to added durability and rigidity plus even roomier interiors.

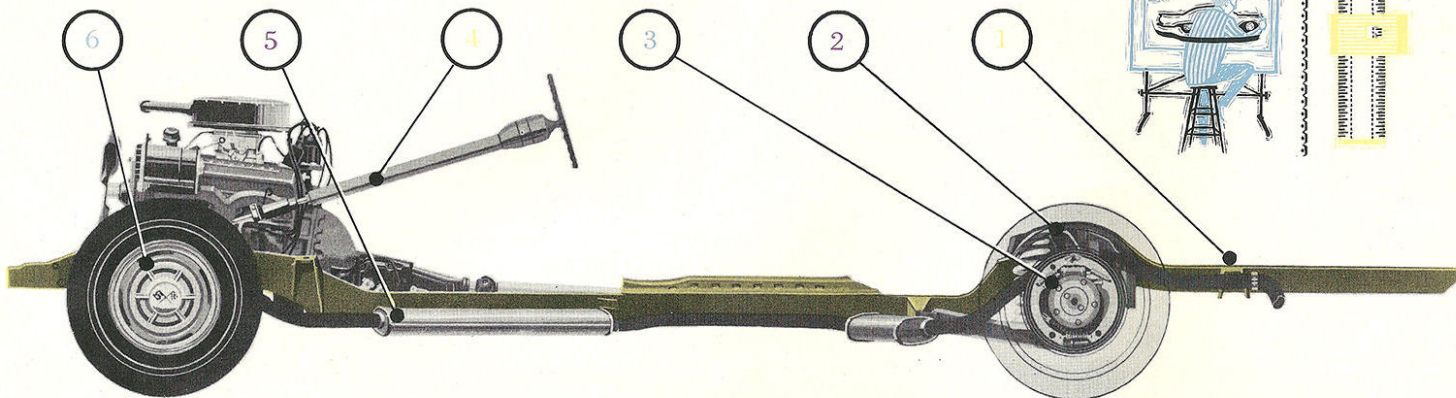

### 1 Safety-Girder Frame

Chevrolet's X-built frame with heavy box-section construction offers torsional rigidity and strength to afford maximum resistance to twisting—keeps body and suspension parts in proper alignment. Design improvements in '60 make possible a lower, narrower transmission floor tunnel for a substantial increase in passenger foot room. A new crossmember adds to frame rigidity, increases durability, and helps to distribute braking and driving forces equally between the two side rails. Chevy's long 119-inch wheelbase and wide tread give '60 taxicabs top stability and comfort on any road.

2

### Full Coil suspension

Smooth-riding Full Coil suspension in every new Chevrolet soaks up bumps and road shocks like no other system on the road. Coil springs are friction-free, smooth and quiet, and need no cleaning or greasing. Built-in anti-dive

control helps keep the car level even during sudden starts or severe stops. A rugged control bar plus husky upper and lower control arms stabilize the rear suspension. Low-friction front suspension spherical joints make Chevy's steering smooth, precise, and easy under all driving conditions.

3

### Safety-Master brakes

Big brake drums and extra-large bonded linings give Safety-Master brakes reserve stopping power and long life. New larger front brake cylinders result in better balanced front and rear wheel braking effort for safer straight-line stops. Chevy's Safety-Master brakes are air cooled, too, for longer lining life. New parking brake mechanism eliminates pedal-release kickback, and permits an extra pedal stroke if necessary to set the brake tight.

4

### Ball-Race steering

High overall ratio of 28:1 lets 1960 Chevrolet taxicabs steer easily even in the tightest traffic situation. The

cushion-jointed steering column helps isolate the steering wheel from road shock, and also permits an excellent steering wheel position for relaxed driving.

5

### maintenance-saving exhaust system

Every Chevrolet muffler is zinc-coated for long life. Excellent sound-deadening qualities contribute to the quiet ride in the 1960 taxicab.

6

### precision-balanced wheels and tires

Wheels and tires are precision-balanced as a unit for extra smoothness and longer tire life. All 1960 tires feature high-strength Tyrex cord construction and new, longer lasting tread material. Soft riding, cool running, easy rolling—they offer better traction, blowout resistance, longer overall tire life and contribute to fuel economy. The slotted wheels permit easy installation of strap-on emergency tire chains for taxicab service in the roughest weather.

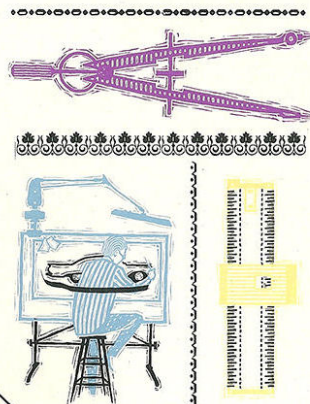

## a wide selection of taxicab-approved options and custom feature accessories\*

### comfort — safety — appearance

HEATER-DEFROSTER Air Flow—outside air	F.O.A. 101
HEATER-DEFROSTER Recirculating	F.O.A. 116
2-SPEED ELECTRIC WINDSHIELD WIPER	
Includes pushbutton windshield washer	R.P.O. 333
WINDSHIELD WASHER Pushbutton	F.O.A. 109
DE LUXE STEERING WHEEL	
Includes horn ring	R.P.O. 348
EXTRA-HEAVY FOAM PADDED FRONT SEAT CUSHION	R.P.O. 335

### power assists

POWER STEERING	R.P.O. 324
POWER BRAKES	R.P.O. 412

### heavy-duty and mechanical

HEAVY-DUTY CLUTCH For Hi-Thrift 6 engine (Included in R.P.O. 330)	R.P.O. 227
OIL FILTER For Hi-Thrift 6 engine	R.P.O. 237
OIL-BATH AIR CLEANER For Hi-Thrift 6 (Available separately if Positive-Type Crankcase Ventilation is not ordered)	R.P.O. 216

### special generators\*\*

- GENERATOR, 30-AMPERE (Standard) Included here as basis of comparison.
- GENERATOR, 35-AMPERE (R.P.O. 338) Extra output standard-duty generator. For use in taxicabs without two-way radio.
- GENERATOR, 40-AMPERE (R.P.O. 326) High-output medium-duty generator. For use in taxicabs without two-way radio.
- GENERATOR, 35-AMPERE LOW-CUT-IN (L.P.O. 1000) Medium-duty generator for peak output at lower speeds. For use in city operation.
- GENERATOR, 50-AMPERE LOW-CUT-IN (R.P.O. 378) Generator with extra-heavy-duty construction, for higher current at very low speeds, such as city taxi operation with two-way radio.
- GENERATOR, 60-AMPERE ALTERNATOR TYPE (L.P.O. 1055) Heavy-duty self-rectifying alternating current generator fits standard generator mounting. All-transistor regulator. Produces high output at idle and low speeds. Special for taxicabs with two-way radios.

\* OPTIONS AND CUSTOM FEATURE ACCESSORIES AT EXTRA COST.  
\*\* CONTACT YOUR LOCAL AUTHORIZED CHEVROLET DEALER FOR OTHER SPECIAL GENERATORS AND ALTERNATORS TO FILL SPECIAL REQUIREMENTS.

POSITIVE-TYPE CRANKCASE VENTILATION For Hi-Thrift 6 engine. Includes oil-bath air cleaner. Not available with Power Brakes	L.P.O. 1019
HEAVY-DUTY BATTERY 70-Ampere-hour rating	R.P.O. 345

### special order equipment

Equipment to meet the demands of unusual requirements and special types of operation should be discussed with your local authorized Chevrolet Dealer. He can advise what can be obtained on special order as factory-installed equipment.

### custom feature accessories

In addition to factory-installed equipment, Chevrolet offers a complete line of dealer-installed Custom Feature accessories. Included are many items particularly suited for taxicab use. Contact your local authorized Chevrolet Dealer for complete information.

### r.p.o. 330 special taxicab option package

Equipment especially desired for taxi duty is offered in a single "package" which includes factory-installed chassis and body features—available at nominal cost and fully described on pages 4 and 5.

- 15" wheels and Tyrex cord tires.
- choice of interior trim.
- heavy-duty rear axle.
- longer wear front suspension.
- open-door warning light.
- heavy-duty rear suspension bushings.
- heavy-traffic spark plugs.
- automatic light switches.
- driveshaft lubrication fittings.
- special ignition-starter switch.
- heavy-duty springs.
- heavy-duty front and rear floor mats.
- wider opening rear doors.
- heavy-duty brake drums.
- rear door armrests.
- special taxicab carburetor.
- heavy-duty front seat.
- heavy-duty rear seat.
- heavy-duty clutch and transmission.
- heavy-duty shock absorbers.

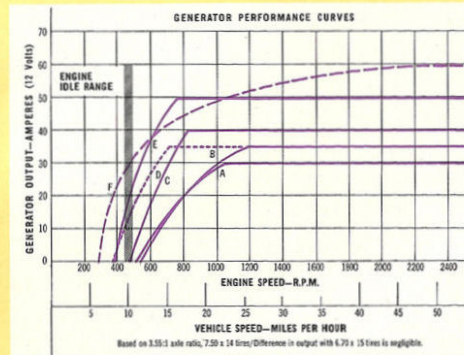

## Biscayne 4-door taxicabs

# specifications models 1119 (6-cyl.) and 1219 (V8)

### power teams for taxicabs

	Synchro-Mesh	Powerglide
Hi-Thrift 6.....	●	●
Economy Turbo-Fire V8.....	●	●

### engine

**Hi-Thrift 6**—135 horsepower at 4000 r.p.m., 235.5 cu. in. 6-cylinder, 3.56" bore and 3.94" stroke, 8.25:1 compression ratio. Single-barrel carburetor with oil-wetted air cleaner (oil-bath type optional\*). Taxi-engineered economy carburetor included in R.P.O. 330\*. Shaft-mounted rocker arms, replaceable valve guides, four main bearings, gear-driven camshaft, by-pass type oil filter\*, five-quart oil refill (without filter).

**Economy Turbo-Fire V8**—170 horsepower at 4200 r.p.m., 283 cu. in. V8, 3.88" bore and 3.0" stroke, 8.5:1 compression ratio. Two-barrel carburetor with replaceable element air cleaner. Single exhaust system. Features independent operating mechanism for each valve, integral valve guides, chain-driven camshaft, five main bearings, full-flow oil filter, four-quart oil refill (without filter).

**both engines**—Valve-in-head design, hydraulic valve lifters, aluminum pistons, forged steel crankshaft, replaceable-insert main and connecting rod bearings, full-pressure lubrication, 12-volt electrical system, positive-shift starter, automatic choke. Cooling system has tube-on-center type radiator, 13-pound pressure cap.

### transmission

**Synchro-Mesh**—Three-speed all helical gear, high torque capacity Synchro-Mesh, hardened shot-peened gears, cam and roller shift mechanism. Gear ratios matched to power team: Hi-Thrift 6, first and reverse 2.94:1, second 1.68:1, third 1:1; Economy Turbo-Fire V8, first 2.47:1; second 1.53:1; third 1:1; reverse 2.80:1.

**Powerglide\***—Three-element torque converter (pump, turbine, and stator) with automatically controlled planetary gears in "Drive" range, manually selected for "Low" and "Reverse." Positive parking lock. P-R-N-D-L selector quadrant on steering column. Engine starts in either "Park" or "Neutral."

### clutch

9½" diaphragm spring type clutch standard with Hi-Thrift 6 engine—10" standard with Economy Turbo-Fire V8. 11" heavy-duty semi-centrifugal diaphragm-spring type clutch optional\* for Hi-Thrift 6 (included in R.P.O. 330\*). Clutches have cushioned disc and permanently lubricated release bearing.

### chassis

**frame and suspension**—Tunnel-center X-built Safety-Girder frame. Full Coil suspension, double-acting shock absorbers and built-in leveling control (heavy-duty coil springs and shock absorbers included in R.P.O. 330\*). Independent front suspension with self-adjusting spherical joint steering knuckles. Four-link rear suspension with

rugged control arms controls axle movement. Front ride stabilizer bar on V8 models.

**wheels and tires**—14" wheels, 7.50 x 14 4-ply rating low-pressure Tyrex cord tubeless tires standard (15" wheels and 6.70 x 15 4-ply rating tires included in R.P.O. 330\*).

**brakes**—Hydraulic Safety-Master brakes with bonded linings. Total lining area 199.5 square inches. 11" diameter drums. Foot-operated mechanical parking brake, T-handle release.

**steering**—Ball-Race steering gear, balanced relay linkage. Overall ratio 28:1.

**rear axle and propeller shaft**—Hypoid, semi-floating rear axle with banjo-type housing. Axle ratio matched to power team. Two-section tubular propeller shaft and three pre-lubricated universal joints (lubrication fittings included in R.P.O. 330\*) with rubber-mounted center bearing.

**fuel tank**—Fuel tank with filter screen is vented to speed filling. 20-gallon tank capacity.

**electrical system**—12-volt electrical system, 54-plate battery (53-ampere hour rating at 20 hours). 30-ampere generator with sealed voltage and current regulator (heavy-duty generator or AC alternator optional\*).

### body

**structure**—All-welded Fisher Unisteel construction. Double-walled cowl and unitized sides. Box-section pillars and floor side rails. Reinforced steel floor and top. W-strut bracing behind rear seat. Double-walled doors, triple-safe rotary latches. Single key operates all locks. Front-opening double-panel hood, automatic latch and safety catch. High-Level cowl ventilation inlet. Large rear luggage compartment, automatic locking lid with counter-balancing hinges and key release. Concealed central fuel filler in rear. Fully sealed and insulated body, cushioned mountings.

**exterior**—Magic-Mirror acrylic lacquer finish in solid colors or two-tone combinations\*. Chrome wraparound front and rear bumpers. Anodized aluminum grille integrated with horizontal dual headlights. Embossed bright metal hub caps. Bright metal moldings outlining rear deck.

**interior**—Seats with S-wire springs (heavy-duty springs included in R.P.O. 330\*). Combination pattern cloth and leather-grained vinyl seat upholstery (two-tone gray all-vinyl available with R.P.O. 330\*). Manual inclined-plane front seat adjustment. All-vinyl side trim. Cloth headlining (except with optional all-vinyl interior\*). Front armrests (rear armrests included in R.P.O. 330\*). Two-spoke recessed-hub steering wheel and horn button. Two sun visors. Top mounted rearview mirror. Ceiling light controlled by instrument panel switch (automatic light switches at all 4 doors included in R.P.O. 330\*). Vinyl-coated rubber floor mats front and rear (all-rubber heavy-duty mats included in R.P.O. 330\*). Rubber luggage compartment mat. Spare wheel and tire, bumper jack, and wheel wrench stowed in luggage compartment.

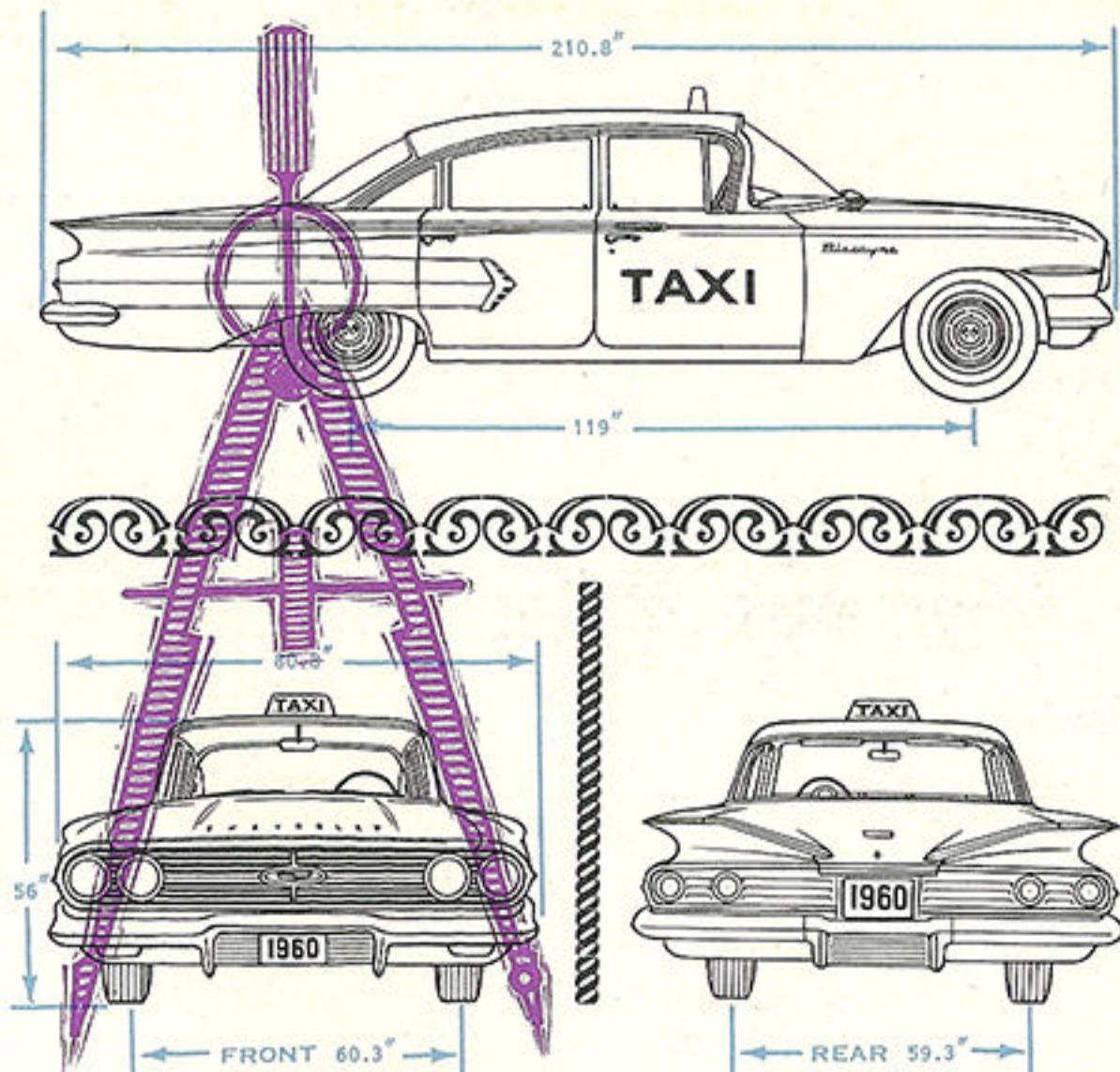

**instrument panel and controls**—Hooded non-glare instruments. Central ashtray with cigarette lighter. Glove compartment with key lock. Instruments: round speedometer with odometer, temperature and fuel gauges, generator and oil pressure lights, country-beam and directional signal indicator lights. Light switch controls headlights, parking lights, instrument panel lights and dome light. Windshield wiper control and starter-ignition switch included in group. Optional\* heater-defroster controls at right of driver. Control knob for air vents under each end of instrument panel. T-handle release for foot-operated parking brake. Directional signal and shift levers on steering column.

**windows**—Safety Plate Glass in all windows. One-piece curved Vista-Panoramic windshield. Crank-operated front vent windows and side windows. Full-view rear window. Electric dual windshield wipers.

### factory-installed options\*

For a more complete list of Chevrolet options for taxicabs see page 11 of this book.

### seat dimensions

	Front	Rear
Leg Room.....	44.5"	42.5"
Head Room (effective).....	39.5"	38.2"
Hip Room.....	65.3"	65.4"
Shoulder Room.....	60.5"	59.0"

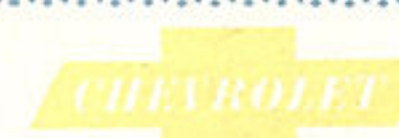

ALL ILLUSTRATIONS AND SPECIFICATIONS CONTAINED IN THIS LITERATURE ARE BASED ON THE LATEST PRODUCT INFORMATION AVAILABLE AT THE TIME OF PUBLICATION APPROVAL. THE RIGHT IS RESERVED TO MAKE CHANGES AT ANY TIME WITHOUT NOTICE IN PRICES, COLORS, MATERIALS, EQUIPMENT, SPECIFICATIONS AND MODELS, AND ALSO TO DISCONTINUE MODELS. CHEVROLET MOTOR DIVISION OF GENERAL MOTORS CORPORATION, DETROIT 2, MICHIGAN.

\*OPTIONAL AT EXTRA COST.

for the greatest value in taxicabs — see your local authorized Chevrolet dealer