

# DODGE 1973





# For 59 years, Dodge has been known for innovative engineering... 1973 is no exception.

"Were they so disposed, Dodge Brothers could not lower the quality of their products . . . because public opinion has established a standard for everything bearing their name. And . . . the public expects constant improvement of any product in which they repose supreme confidence."

This excerpt taken from a Dodge car catalog written in 1919 represented the Dodge Brothers' early attitude about building automobiles. And it still represents Dodge Division's attitude today. Through the years, Dodge has pioneered such innovations as the four-door sedan in 1919 . . . a full front seat in 1921 . . . a hand-operated windshield cleaner in 1921 . . . and the industry's first all-steel coupe body introduced in June, 1922.

## AND TODAY:

In 1973, Dodge comes on strong with a host of meaningful engineering advancements.

The Electronic Ignition System. Cleaner Air System. Torsion-Quiet Ride. Super-Quiet package on Charger SE. Electronic Security Alarm System. Extra-protection bumpers and bumper guards. Improved Windshield Wipers. New Sliding Metal Sun Roof. And there's more that's all new and meaningful to your motoring enjoyment with Dodge.

Ever since the first Dodge was built . . . a 1914 Dodge Touring car is shown in the cover alongside a 1973 Polara 4-door Hardtop. *You Can Depend On Dodge.*

## '73 Dodge offers the 'Quieter Life'

All 1973 Dodges offer major chassis and interior improvements to reduce interior noise levels. What's more, Charger and Coronet offer Dodge's famous Torsion-Quiet Ride. Until now only available on our full-sized Monaco/Polara series. This is a sophisticated suspension system which helps isolate the passenger compartment from road and engine noises through the use of strategically located rubber mounts, extra padding, and insulation materials. Charger SE goes a step further with a premium silencing package that indeed makes it a super quiet car.

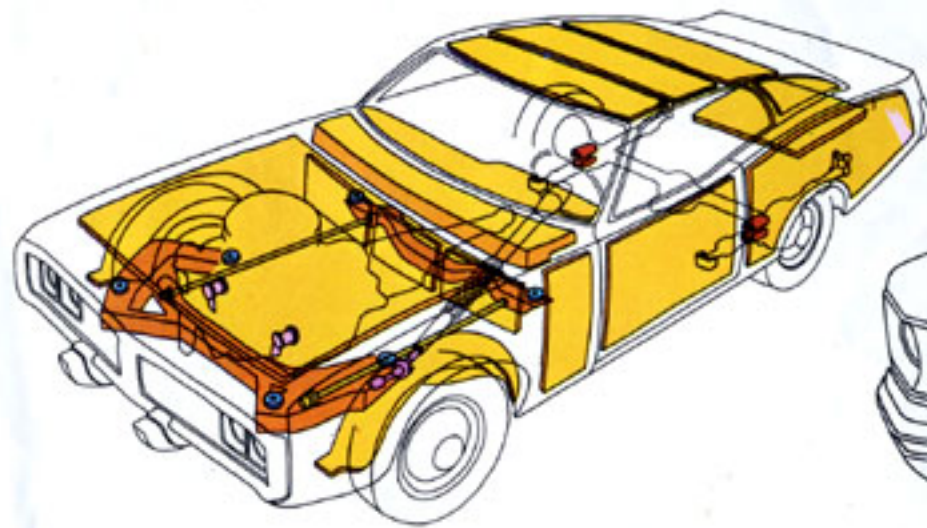

Charger SE  
The Super-Quiet Car

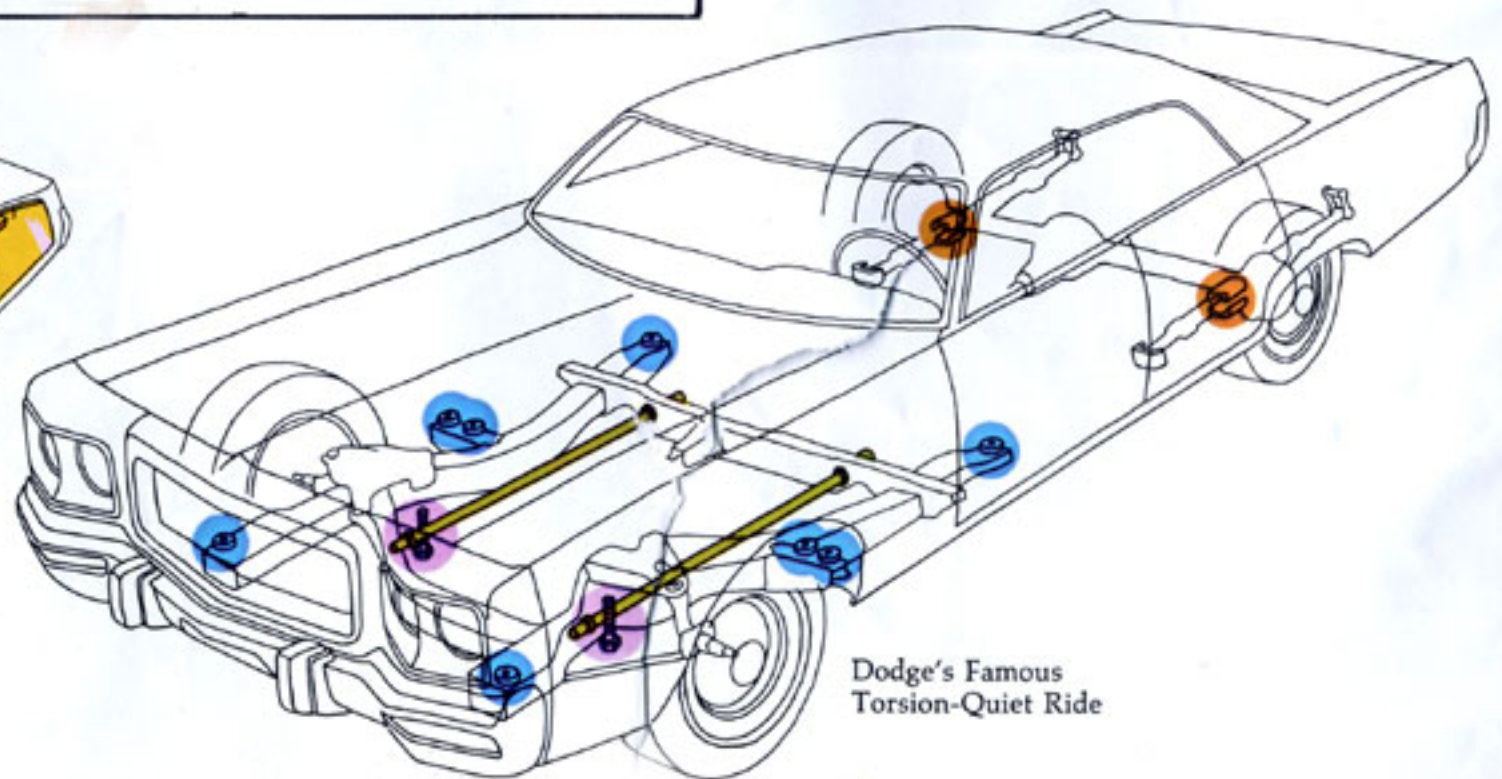

Dodge's Famous  
Torsion-Quiet Ride



## New Electronic Security Alarm System for Monaco and Polara.

An Electronic Security Alarm System is optional on all '73 Monacos and Polaras. When a violation of hood, doors, or trunk lid occurs, headlights, tail-lights, and side marker lights flash in conjunction with a pulsing of the horn. The alarm continues as long as the violation exists or until shut off with the ignition-door key. It then rearms itself automatically. The system is camouflaged and is built into your car's regular wiring system to thwart tampering.

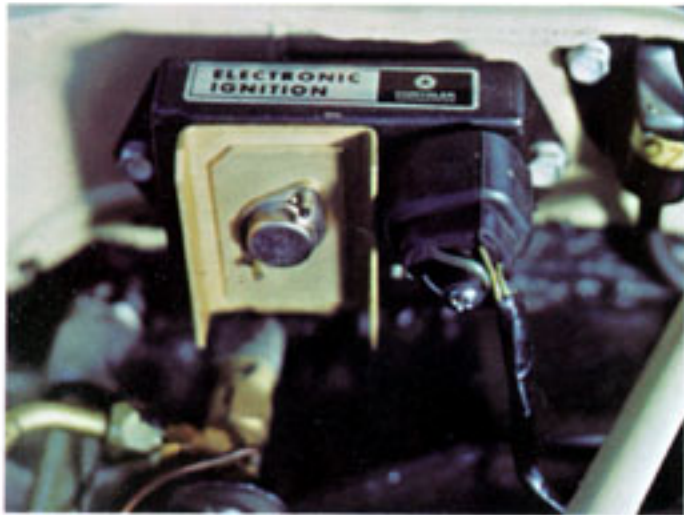
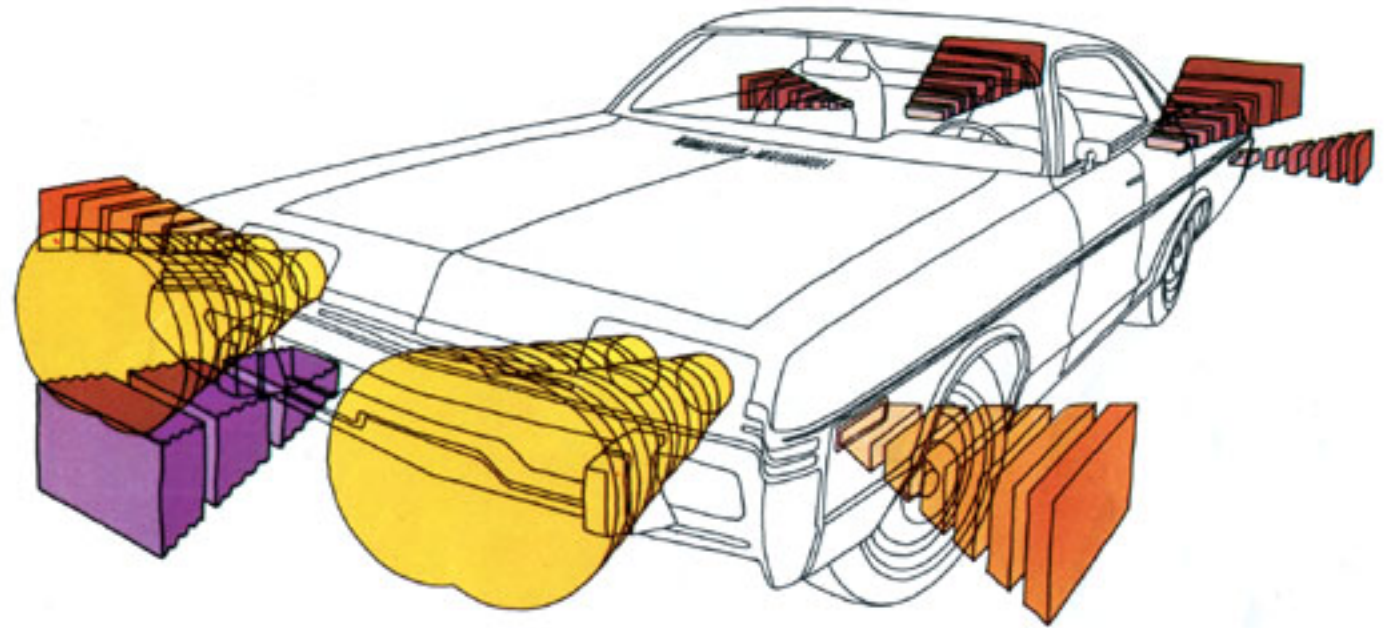

## New Electronic Ignition System Standard Equipment

Proved in a million miles of street and highway driving, this revolutionary new system offers many advantages over conventional ignition systems. Faster starts in the hottest or coldest weather, no points or condenser to replace come tune-up time, engine emissions greatly reduced and misfires at highway speeds virtually a thing of the past make the new Electronic Ignition System a real step forward...it's practically maintenance-free. However if your ignition does need some attention, your Dodge Distributor can pinpoint the problem quickly and easily with the new, Chrysler-designed Electronic Ignition analyzer.



## New High-Speed Starter Motor

New on 360 cid V8's and larger engines is a new, higher speed starter motor. This new starter motor cranks the engine approximately 33% faster at 70°F than previous motors. In really hot conditions, say 80°F and above, restarting times have been reduced appreciably. It provides faster starts in cold weather. It's Chrysler's extra care in engineering working for you.

### FOR YOUR COMFORT

All Polara, Monaco, Charger and Coronet models have as standard a heater/defroster system with Upper Level Ventilation.

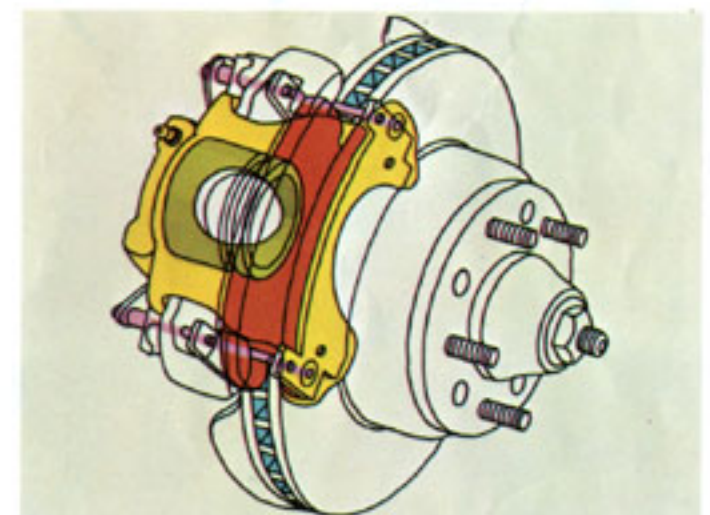

## Improved Floating-Caliper Disc Brakes

Front disc brakes are standard on all Dodge cars for '73, (except six-cylinder Darts). Designed to increase stopping power and reduce maintenance costs, the ventilated discs help transfer heat over a larger area...brakes stay cooler, more efficient. Service is faster and costs less too, as brake pads can be checked visually through the caliper access hole.







# Monaco comes on bold... but quietly.

Monaco has a special quiet feel that whispers "quality" in big car performance. Standard features like Torsion-Quiet Ride, power steering, and caliper-type power front disc brakes provide a cushion-smooth ride, great handling and smooth stopping. Road noises and vibrations are reduced to a minimum.

Inside, Monaco's soft and stylish. Standard seating is rich cloth-and-vinyl bench with centre arm rest in your choice of blue, green, parchment, black or gold. Or choose the optional all-vinyl bench in the same colours. Wood-grain patterned trim highlights the doors and the functional, easy to read instrument panel. Colour coordinated deep pile carpeting completes the quiet, comfortable picture.

Monaco has more than good looks. A 360 cid V8 offers unusual engine response and economic operation on regu-

lar gasoline. Torque Flite automatic transmission is standard. For a little extra power on the open road, you can move up to a 400 or 440 cid V8. Standard in all engines is the revolutionary Electronic Ignition System that's practically maintenance free.

All Monaco models come in your choice of 17 Acrylustre colours. Whatever your choice—two or four door hardtop, four door sedan, or two or three seat wagon all ride on a long 122" wheelbase.

1973 Dodge Monaco offering the quiet satisfaction of luxury class driving that'll surprise you. That's because Dodge builds in the solid difference.

Solid difference is built into the Monaco Brougham too—the brilliant flagship of the '73 Dodge line. You can make your Monaco Brougham as personal as you wish from a broad selection of options.



Monaco 4-door Hardtop



Monaco 4-door Sedan

◀ Monaco 2-door Hardtop

Handsome burlled-walnut trim accent

Monaco's all-new rear-end design



Monaco's Luxurious Daker cloth-and-vinyl interior







# Polara and Polara Custom...

## The big Dodges that make a lot of sense.

Dodge Polara and Polara Custom make it easy to step into the world of quiet. Big, good looking, smooth riding, priced right . . . That's Polara. It's for people who want a lot of room, comfort and performance, but don't want to pay a lot for the advantages.

The choice is another big factor why Polaras are so popular, 2-door hardtops, 4-door sedans and hardtops, for you wagon fanciers there are 2 and 3 seaters. All ride on a solid 122" wheelbase and all come with famous Torsion-Quiet Ride with added sound insulation to keep them really quiet.

Standard front seating is an impressive cloth and vinyl bench in blue, green, black, or gold. But naturally there's a choice,

you can opt for the all vinyl bench with centre arm rests in blue, green, parchment, black or gold. For 2-door hardtop, go sporty with vinyl highback buckets in black or parchment.

You'll notice sumptuous little details like simulated wood-grain interior panelling, extra protective ideas like new impact absorbing bumpers and a vinyl inserted body side moulding. You'll feel the benefit of *big* ideas like power steering, power front disc brakes. TorqueFlite Automatic, Electronic Ignition, and a big 318 V8 ...all standard. When we say Dodge builds in the solid difference, Polara proves it in more ways than one.



Polara Custom 4-door Sedan



Polara Custom 2-door Hardtop



Polara Custom's cloth-and-vinyl interior



Polara's bold new front styling







# Charger and Charger SE... for the young at heart.

Heads turn and there's lots of Oohs and Ahhs! Take it in your stride, it's to be expected when you own a car as personally luxurious and as classically styled as SE. Ideas like rakish, louvered upper quarter windows marry beautifully with the smooth, undisturbed lines. Inside, silence and comfort abound, but function is still very, very evident. Easy to read, wood-grained patterned rallye instruments cluster, deep-pile carpeting, all-vinyl bench seats with center arm rest in wide color range, say "Special" all the way. Naturally there's a stack of options you can choose from to make your SE more you. Charger SE, a car that fulfills most people's dreams.

Other beautiful Chargers in two-door

A special Rallye package is available for both coupe and hardtop. And special it is, with a snappy 318 V8, power bulge hood, rallye instrument cluster, front and rear sway bars, neat looking hood pins, black body side tape stripes with "Charger" call-out and F70 x 14 RWL tires complete the tough picture. Grrrrr!



Charger Rallye Hardtop



Charger Rallye Coupe

hardtop and two-door coupes offer outstanding sports performance and style . . . but!, you'll still get family room and comfort. Among the impressive standard list of features are: Torsion-Quiet Ride; front disc brakes; the new Electronic Ignition System; extra protection impact absorbing bumpers. Standard engines are a 225 slant six or 318 V8, both are at home on the highway or in the city.

To further add to Charger styling, order yours with a canopy-style vinyl roof, and there's even a sliding sun roof.

That's it, Charger for '73 . . . go ahead, think young.



Charger 2-door Coupe



Charger's sliding metal sun roof



Optional "Halo" style vinyl roof

Optional bucket seats and center console







# Coronet and Coronet Custom... part of the Dodge family.

A lot of families who own a Coronet think we designed it just for them. That makes sense. We did. From its big roominess that takes in the whole family and all its luggage, to the smooth, economical performance, Coronet fits right in with any family's plan.

Four-door sedans on a 118" wheel-base are the specialty with Coronet and Coronet Custom. You get a standard engine choice between a 225 cid Slant Six and 318 V8. Other standard features include Chrysler's revolutionary Electronic Ignition System, Torsion-Quiet Ride, and

front disc brakes.

Inside the fully unitized body, there's family room, plus. All-vinyl bench seats on Coronet and rich pleated cloth-and-vinyl bench in four colours on Coronet Custom, are standard. For any occasion, especially the extra-fancy ones, you'll like the way Coronet Custom dresses up inside—wood-grained pattern instrument panel applique and door trim inserts, plus colour keyed carpeting.

Families can feel solidly at home in Coronet for '73. That's the solid difference in Dodge.



Coronet 4-door Sedan



Coronet Custom's cologne cloth-and-vinyl interior . . .  
with ample family-sized rear seat.



Compare Coronet's room to that of any car in its class, or that of *any* car, for that matter. You'll see why Coronet is called family size. Trunk has capacity to hold a lady's pullman, wardrobe, two train cases, and four overnight bags, plus a man's overnight bag, two 2-suiters, and even his bag of golf clubs.

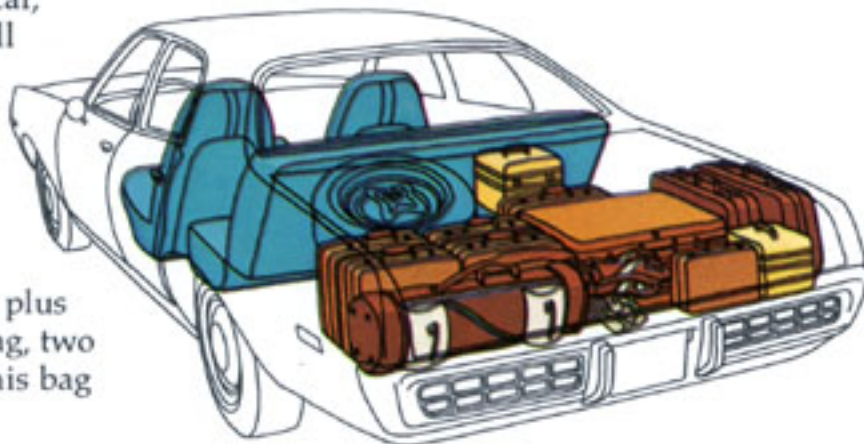





DODGE  
CHALLENGER



# Challenger...

you can take it very personally.

Because you know the feel of a personal sports compact...a car that's not for everyone, but one that fits right into your world... Challenger is waiting.

Talk about looks and performance...you're talking about Challenger. Sleek exterior lines highlight the quick response you get from the standard 318 cid V8 or the optional 340 cid V8. Both are equipped with Chrysler's revolutionary Electronic Ignition System.

Rallye performance? It starts with the firm feel of manual floor shift and front disc brakes. It keeps getting better as you move into the special Challenger Rallye package—special instrument cluster featuring 150-mph speedometer, plus unique grille and lower deck panel treatment and strobe side stripes on the doors and side panels. And for real rally response and handling, hood scoops and heavy duty shock absorbers.

Standard seats on Challenger are vinyl buckets in blue, green, black, black and white.

Challenger has everything to put you in your own, and way out ahead.



Challenger

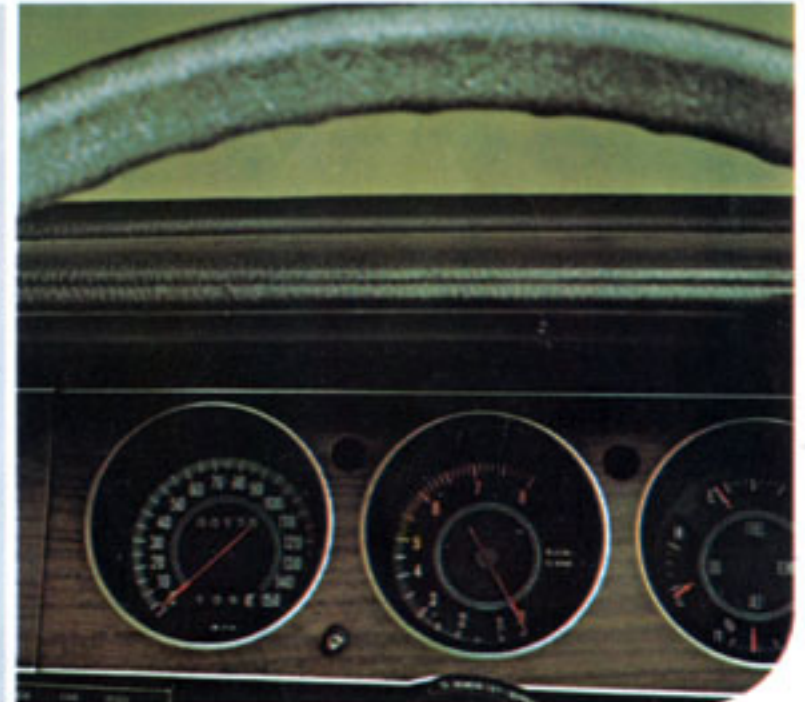

Challenger's Empire vinyl bucket seats and Challenger Rallye instrument cluster







# Dart Sport...

the three-in-one compact that's great on value.

Meet *Car One*. Dart Sport. Quite a car just the way it is—five-passenger economy coupe, with a large trunk to tote all the family gear, and torsion bar suspension for handling stability. Add the optional sliding sun roof and you've got *Car Two*. Neat option this to let the sunshine in. Order the Sport with the fold-down rear seat and you have *Car Three*.

A three passenger car with space for sports gear

and camping equipment. Now

that you've met

*Car One*, *Two*,

*Three*...surprise,

meet number *Four*. Dart 340 Sport. Big 340 cu. in. four-barrel is standard, along with rallye suspension and dual exhausts. The 'up and over' tape treatment shown is optional for both Sport models.

Standard equipment on Sport and Sport 340 includes the revolutionary Electronic Ignition System. Seating is a cloth and vinyl bench in your choice of blue, green or black, or an optional all-vinyl bench with or without centre arm rests in an even wider color range. If you go for buckets, we've got those too, white, parchment or black. A 198 six or 318 V8 is the standard power plant on Sport. A roaring 340, four-barrel job does it for Sport 340. Disc brakes up front are standard on V8 models. Power assisted on Sport 340. Inside, there's a lot of wood-grain, around the instruments and a lot of solid comfort too. How about that Dart—three cars in one, plus one.

Like we say, if you're going to go at all...go Dart. That's The Dodge Difference.



Sport Coupe



Dart Sport and 340 Sport bucket seats



A locked trunk of generous proportions with the security panel raised to its upright position. Security panel latch can be opened from trunk side only.



Dart Sport's Optional Utility Package gives you six and one half feet of carpeted cargo area with the security panel and rear seat folded down.

And thanks to the fold-down feature of Dart Sport's front seat, you've got even more room on the passenger side for those extra-long items.





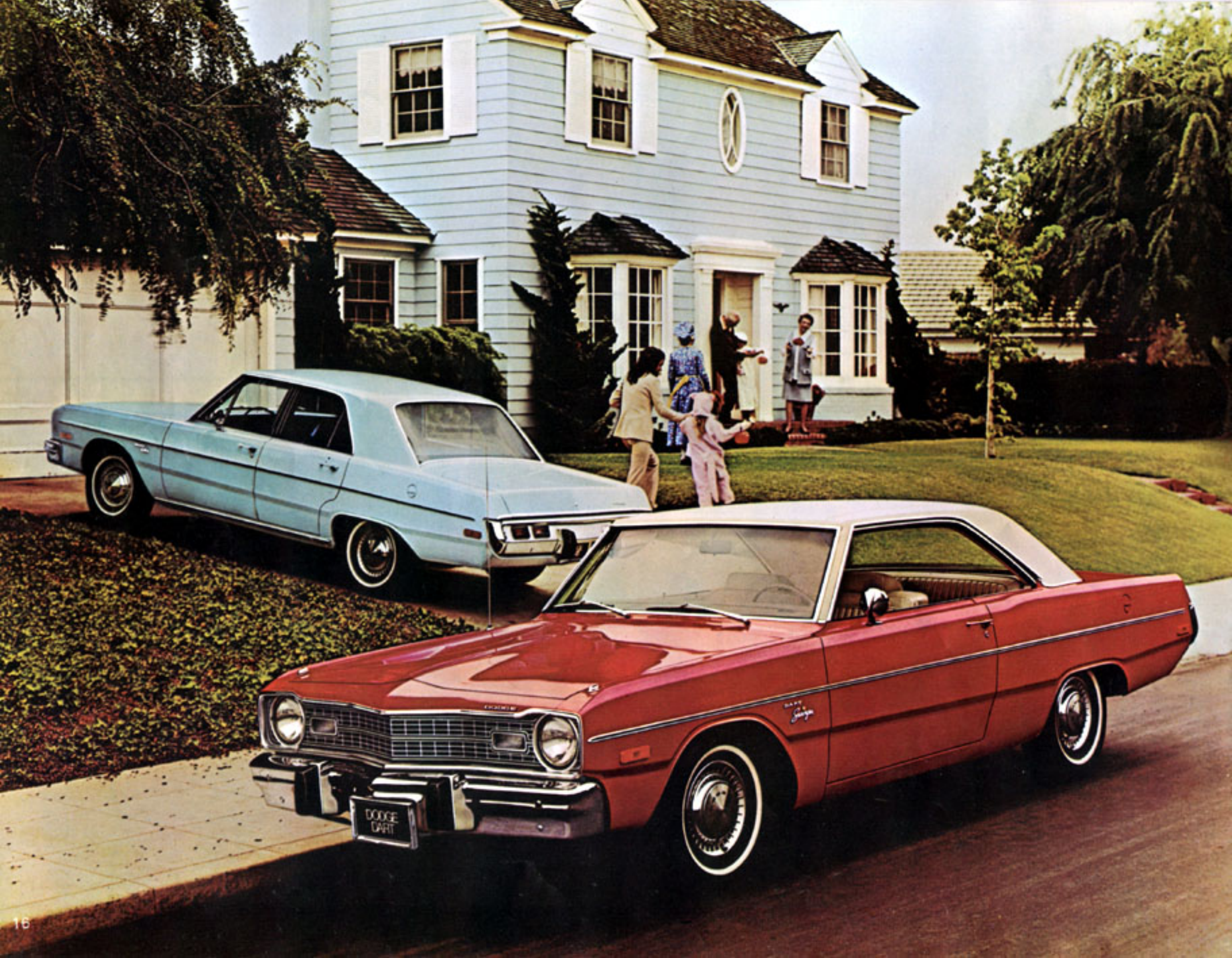



# Dodge Dart... more than one million sold to the economy minded.

Dart is one of the most appealing economy cars ever built. The car many people know and love.

Dart, Dart Swinger and Custom prove you don't have to stint on performance and comfort in order to get economy.

Take the Swinger hardtop. Standard engine choices are a 198 cid Slant Six and 318 V8. Inside, deep-pile carpeting, wood-grained instrument panel, and full-width vinyl bench seat with applied head rests give you comfort and style you'd expect in a bigger car. A lower-priced Swinger Special is also available.

Dart Custom and Dart sedans do everything a family needs, smoothly and quietly.

Big enough for six people and, like Swinger, there is unusual trunk space because the spare tire is hidden under the floor.

In tight parking, cramped city driving, or on the open road, Dart holds its own on a tight 111" wheelbase with torsion-bar suspension. Other Chrysler extra care in engineering features include unitized body and the revolutionary Electronic Ignition System.

And, there's an optional sliding metal sun roof available on the 2 door models.

Dodge Dart for '73...everything you want in a compact, and that includes value.



Dart Custom cloth-and-vinyl interior—above

Optional Swinger interior, including fold-down center armrest and interior decor group.



Dart  
4-door Sedan



Dart Swinger Special 2-door hardtop



Swinger and Custom 4-door Sedan



Dart's standard bumper, hidden spare tire, and hard to believe luggage space.



Dart's attractive instrument panel



# Dodge Wagons...

Mid-size to full-size, the Dodge Difference makes them economy-size.

## Full-size Wagons:

Dodge full-size wagons combine the smooth driving and handling of a full-size car with living-room comfort. Take a look at the standard features on Monaco, Polara Custom and Polara. TorqueFlite automatic transmission, power steering, power front disc brakes, heating/defrosting with upper level ventilation, Torsion-Quiet Ride, power tailgate window, three-way tailgate, a special rear air deflector that helps keep the rear window free from road dust, and Chrysler's revolutionary Electronic Ignition System. For safety when you're driving with children in three-seat models, there's an "Auto-Lock" system that automatically locks the rear door when the ignition is on. Durable and beautiful vinyl bench seats are standard.

You'll find more than ample power in the Polara, Polara Custom and Monaco Wagons. The big 360 cid V8 is standard. All three are on a 122" wheelbase. Monaco and Polara Custom come in 2-seat and 3-seat versions.

How about options to suit your particular needs? They include a roof luggage rack, power seats, power windows, and Air Temp air conditioning, AM/FM radio, cargo deck carpeting, the Security Alarm System, a Trailer Towing Package and more!



The air deflector forces a portion of the air flowing over the roof downward over the rear window to prevent dirt from collecting, and prevents exhaust fumes, dust and rain coming in when the window is open. It's standard on Monaco, Polara and Coronet Crestwood.



The three-way tailgate opens wide like a door with the window glass either up or down or it folds down to handle extra long loads. A special "Auto-Lock" system on three-seaters automatically locks the rear door when the ignition is on.

## Mid-size Wagons:

Dodge's mid-size wagons give you big performance and comfort. A host of model, engine and option choices let you tailor your wagon to your exact needs. All models feature unitized body construction, Torsion-Quiet Ride and power front disc brakes. The standard engine on all the Coronet wagons is a peppy 318 cid V8 and comes equipped with the new Electronic Ignition System. All come on a trim, stable 118" wheelbase. Coronet Crestwood is a truly luxurious wagon, combining rich wood grained styling outside, a beautiful and practical interior, with cargo deck carpeting, rugged engineering and big roominess. Coronet and Coronet Custom are ideal for economy operation with a flair. On three-seat wagons, the special Auto-Lock Tailgate is standard. Two-seat models provide a hidden storage compartment for valuables under the rear floor. Whether you choose two or three-seat models, you still get the same big cargo capacity and three-way tailgate.



Standard on all wagons are extra storage compartments on both sides of rear cargo area.



A Dual unit Air Conditioner is available for Polara/Monaco wagons. The rear unit is mounted at the roof level. Provides the extra cooling for rear seat passengers.



With the rear seat or seats folded down, the cargo compartment is large enough for a 4' x 8' sheet of plywood to lie flat on the floor. (all models)

Special Trailer-Towing package features Heavy Duty suspension and axle, extra engine cooling, and trailer wiring harness.





# Coronet Wagons...

Mid-size economy  
for the family  
with flair.

Mid-size on a 118" wheelbase, Coronet Wagons provide family roominess and utility in a beautiful package. Pictured at the left is the top-of-the-line Crestwood. The Crestwood and the Coronet Custom are available in 2 or 3 seat models. The practical Coronet is in a 2-seat version only. They are all powered by a 318 cid V8. An optional engine is the 400 cid V8 with 2 barrel or 4 barrel carburetors. Interiors are all-vinyl and designed to take the use and abuse of a growing family. Illustrated at the lower left is the standard seating on the Crestwood. All-vinyl with a pull down centre armrest. Features include a three-way tailgate and the cargo capacity to take a 4' x 8' sheet of plywood flat on the floor.



Coronet Crestwood



Coronet Custom



Coronet



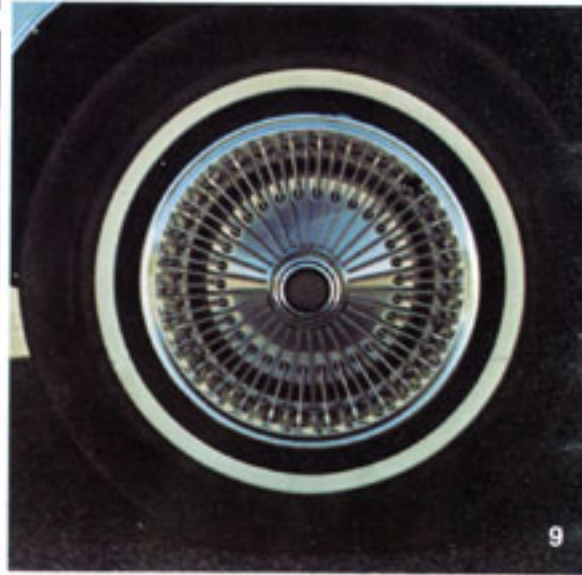
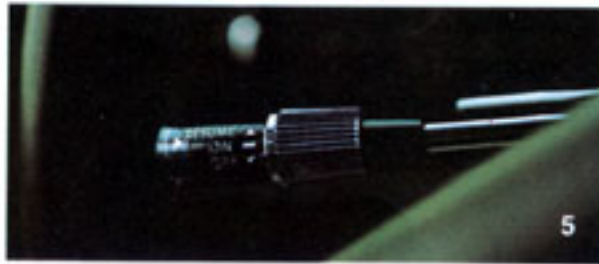



# Options to make your new Dodge as individual as you please.

On these pages you'll find some of the options available to make your new Dodge more convenient, comfortable and beautiful.

## Look, see, select...enjoy.

1. Vinyl Bench Seat with Fold Down Centre Armrest for Polara Custom. Similar type available for some other models.
2. Remote Control Outside Mirror.
3. Slap Stick Automatic Transmission for Challenger and Charger.
4. Electric Heated Rear Window Defroster for Sport Models.
5. Automatic Speed Control for Polara/Monaco.
6. Power Door Locks for Polara/Monaco.
7. Rear Window Defogger (except Station Wagons).
8. Styled Road Wheels for Challenger, Coronet and Charger.
9. Wire Wheel Covers for Coronet and Charger.
10. Styled Road Wheels for Polara/Monaco (except Station Wagons).
11. Sliding Sun Roof for Sport, Swinger and Chargers.
12. Power Disc Brakes. Standard on Polara, Monaco, Coronet Wagons and Sport 340.
13. AM/FM Radio and Air Conditioning.
14. Cornering Lights for Polara and Monaco.
15. Vinyl Bucket Seats for Polara Custom 2-door hardtop. Similar type available for some other models.

There are many other options available to enhance the beauty and comfort of your new Dodge. Your Distributor will be pleased to cover them with you.





# 1973. The Solid Difference in Dodge Design and Engineering.

Listed on this page are examples of the many Dodge innovations, systems, and testing procedures that make your 1973 Dodge the best Dodge ever built. In many areas, such as sound control and emission control systems, Dodge is thinking of you when it comes to automobile performance and safety. Dodge is not only interested in the satisfaction of its customers, but also in the total environment. Comprehensive engine and transmission tests provide additional insurance that your new Dodge is in top shape when you get it, and stays that way. All in all, Dodge design and engineering represents a solid difference you can see and feel.

## Electronic Ignition System

No points to wear out, no condenser to replace. The cost of tune-ups drops considerably, engine emissions are reduced, and engine misfirings at highway speeds are virtually eliminated. It's practically maintenance-free, and if something should go wrong, an electronic testing device lets your Dodge Distributor pinpoint the problem and fix it quickly.

## Wiring Harness Test System

Use of an automatic test system makes possible 100 percent checkout of all wiring circuits during assembly. Exterior lamps, heater motor, power windows, rear

defogger and windshield wipers and more are all checked for possible line loads or short circuits. You can depend on Dodge.

## Transmission Test Computer System

The heart of this system is a Process Automatic Computer. Coupled with manual testing techniques prior to assembly of the transmission into vehicles, the system is capable of subjecting 28 transmissions at one time to the most rigorous testing program. The program, together with regular highway tests, was developed to ensure smooth, efficient transmission operation.

## Emission Control Features

**Electric Assist Choke**—All 1973 engines are equipped with an electric assist choke to help reduce emissions during starting and warm-up. The assist choke shortens the period of choke operation when outside temperatures are above about 68°F, thereby cutting down on emissions.

**Exhaust Gas Recirculation System**—This system, standard on all Dodge models, introduces controlled amounts of exhaust gases into the incoming fuel/air mixture. These recirculated gases serve to lower peak burning temperatures and thereby control the formation of oxides of nitrogen.

## Safety and Extra Protection Features

**Stronger Bumpers**—All 1973 Chrysler-built cars are equipped with extra protection bumper systems. The bumpers can withstand barrier impact forces of 5 mph on the front and 2½ mph on the rear with no significant damage to body or chassis components, including the lights or to the bumper system itself.

The supporting members for front bumpers have been strengthened to distribute the force over a wider area and thus lessen the probability of damage. All bumpers are equipped with large 3-4 inch thick solid-rubber guards that can be compressed up to 60 percent.

**Fire Retardant Materials**—All seat cushions, seat backs, seat belts, headlining, armrests, compartment shelves, head restraints, floor coverings, and trim panels in 1973 Dodge models are made of fire retardant materials. In an emergency, these chemicals provide passengers with added protection by retarding both combustion and the fumes given off by combustion.

**84 Decibel Sound Level**—For 1973, all models have operating sound level no greater than 84 decibels at wide-open-throttle. This has been achieved primarily through modifications to exhaust and air intake systems. This level makes your new Dodge quieter both inside and out.

## Standard and optional engine availability

	Dart Sport	Dart Sport 340	Dart Swingers Custom	Challenger & Rallye	Coronet	Coronet Wagons	Charger	Charger SE	Charger Rallye	Polara & Polara Custom	Monaco (2)
198 cu. in. SIX	S-6		S-6								
225 cu. in. SIX	O		O		S-6		S-6				
318 cu. in. V8 2 bbl.	S-8		S-8	S-8	S-8	S-8	S-8	S-8	S-8	S-8	
340 cu. in. V8 4 bbl.		S-8		O							
360 cu. in. V8 2 bbl.										O (1)	S-8
400 cu. in. V8 2 bbl.					O	O	O	O	O	O	O
400 cu. in. V8 4 bbl.					O	O	O	O	O	O	O
440 cu. in. V8 4 bbl.										O	O
WHEELBASES	108"	108"	111"	110"	118"	118"	115"	115"	115"	122"	122"

S-Standard O-Optional (1) N.A. Polara (2) Also applies to Polara/Polara Custom & Monaco Wagons

## Monaco Brougham



Monaco Brougham  
4-door Sedan



Monaco Brougham  
4-door Hardtop



Monaco  
4-door Hardtop



Monaco  
4-door Sedan



Monaco  
2-door Hardtop



Monaco Station Wagon  
2 and 3 Seat Models

## Polara Custom



Polara Custom  
4-door Sedan



Polara Custom  
4-door Hardtop



Polara Custom  
2-door Hardtop



Polara Custom Station Wagon  
2 and 3 Seat Models

## Polara



Polara  
4-door Sedan



Polara  
2-door Hardtop



Polara Station Wagon  
2 Seat Model

You can depend on Dodge . . . There's a Dodge in '73 that fits any individual's need. From the economical Darts through the sporty Challengers and Chargers, the family Coronets to the luxury of Polaras and Monacos.

## Charger



Charger SE



Charger  
Rallye Hardtop



Charger  
Rallye Coupe



Charger  
Hardtop



Charger  
Coupe

## Coronet



Coronet Custom  
4-door Sedan



Coronet  
4-door Sedan



Coronet Crestwood  
Station Wagon



Coronet Custom  
4-door Station Wagon



Coronet  
4-door Station Wagon

## Challenger



Challenger  
Rallye



Challenger

Dodge Sportsman—a people moving vehicle, up to 15 passengers. It's ideal for the outdoors minded family, or for city shopping. Available wheelbase is 109" and 127".

## Dart



Dart Swinger  
2-door Hardtop



Dart Custom  
4-door Sedan



Dart Sport  
2-door Coupe



Dart Swinger  
Special 2-door Hardtop



Dart  
4-door Sedan



Dart Sport 340  
2-door Coupe

## Sportsman



Royal Sportsman



## 1973 STANDARD SPECIFICATIONS

### MONACO/POLARA

Transmission: 3-speed automatic. Suspension: Torsion-Quiet Ride. Tires: G78 x 15 black sidewall bias-belted (Polara/Polara Custom). H78 x 15 black sidewall bias-belted tires (Monaco). Wagons, 2-seat J78 x 15. 3-seat L84 x 15. Brakes: Power Discs, front. Dual Braking system. Electrical: 41-amp alternator. Transistorized regulator. Electronic Ignition System. Power steering. 23 gallon (U.S.) fuel tank. Exterior Features: Ventless front windows. 2-speed concealed windshield wipers. Concealed headlights and deluxe wheel-covers (Monaco). Interior Features: Cloth and vinyl front bench (Polara/Polara Custom). Cloth and vinyl split-back front bench with center armrest (Monaco), (Wagons—all vinyl). Simulated wood-grained trim in door, 3-spoke steering wheel, and instrument panel (Polara Custom and Monaco). Carpeted door lower panels (Monaco). Cigar lighter. Glove box lock. Heater/Defroster. Keyless door locking system. Foot operated parking brake with hand release. Prismatic day/night inside rearview mirror. Color-keyed carpeting. Dome light (Polara and Polara Custom). Combination dome and map light, instrument panel ash receiver light, glove box light, headlight-on warning buzzer, rear door automatic dome light switch, and trunk light (Monaco).

### CORONET

Transmissions: 3-speed manual, fully synchronized, column-mounted shift. Suspension: Front, Torsion bars and ball joints. Rear, asymmetrical leaf springs. Torsion-Quiet Ride. Tires: \*F78 x 14 BSW bias-belted. Brakes: Disc, front. Hydraulic, dual circuit. Parking brake is foot-operated, mechanically actuating shoes on rear wheels, hand-released. Electrical: Alternator, 41-amp. Transistorized voltage regulator. Electronic ignition system. Interior Features: All-vinyl front and rear bench seats (Coronet and Wagons). Cloth and vinyl front and rear bench seats (Coronet Custom only). Heater/Defroster. Keyless door locking system. 3-spoke color-keyed steering wheel (Custom and Crestwood have simulated wood-grained insert). Day/night inside mirror. Glove box lock. Dome light with front door courtesy switch. Color-keyed carpeting (Custom and Crestwood). Trunk mat. Exterior Features: 2-speed concealed wipers. Dual headlights and taillights. Roof drip-rail, wheel-lip, body side and rear mouldings (Custom and Crestwood). Crestwood—wood-grained body side and tailgate panels. (\*except wagons)

### CHARGER

Transmissions: 3-speed manual fully synchronized column-mounted shift (standard), (Optional 4-speed manual with 318, 340 and 400 4-barrel V-8's). Suspension: Torsion-Quiet Ride. Front sway bar (Charger SE only). Front and rear sway bars (with Rallye and SE 4-barrel V-8 engines). Tires: F78 x 14, (225 and 318 engine). F70 x 14 wide tread (Rallye only). Brakes: Front Discs. Power, optional. Electrical: Alternator, 41-amp. Transistorized voltage regulator. Electronic ignition system. Interior Features: All-vinyl front bench seat. 3-spoke color-keyed steering wheel with spoke horn-blow switches. Simulated wood-grained steering wheel insert (except Coupe). Heater/Defroster.

Keyless door locking system. Foot-operated parking brake with warning light. Glove box lock. Trunk mat. Dome light with door courtesy switch. Color-keyed carpeting, day and night inside mirror, cigar lighter, simulated wood-grained door trim (except Coupe). Simulated wood-grained instrument panel pad applique. (Charger H.T. and SE only). Simulated wood-grained instrument panel with hooded circular instrumentation (Charger SE and Rallye only). Inside hood release (SE only). Exterior Features: Formal vinyl roof with fixed louvered quarter windows (SE only). 2-speed concealed wipers. Bodyside paint stripe (SE only). Performance hood (Rallye only).

### CHALLENGER

Transmissions: 3-on-the-floor synchronized manual. 4-speed manual optional with 340 V-8 only. TorqueFlite optional on 318 or 340 V-8. Suspension: Front, Torsion bars and ball joints. Rear, asymmetrical leaf springs. Oriflow shocks at each wheel. Heavy-duty Rallye suspension package (Rallye or 340 V-8 engine). Tires: 7.35 x 14, polyester, BSW. F70 x 14 bias-belted, WSW (Rallye or 340 engine). Brakes: Disc brakes, front. Power discs standard with 340 V-8. Dual braking system. Electrical: Alternator, 41-amp. Transistorized voltage regulator. Electronic ignition system. Interior Features: All-vinyl bucket seats with integral head restraints. Cigar lighter. Deep-pile carpeting. Dome light. Simulated wood-grained door inserts. Glove box lock. Heater/Defroster. Day/night inside mirror. Keyless door locking system. Rallye instrument cluster (optional). Exterior Features: 2-speed electric windshield wipers. Ventless front windows, wheel opening, roof drip-rail, grille and deck lid mouldings. Dual body paint stripes. Body side performance tape stripes (optional).

### DART

Transmissions: 3-speed manual, column-mounted shift (standard with Six and V-8). Fully synchronized, (standard on V-8's, optional on 6's), floor-mounted shift (standard with 340 V-8). Suspension: Front, Torsion bars and ball joints. Rear, asymmetrical leaf springs. Oriflow shocks at each wheel. Heavy-duty Rallye suspension with 340. Tires: 6.95 x 14 polyester cord (standard except Sport 340). E70 x 14 bias-belted (Sport 340). Brakes: 10" x 2 1/2" front. 9" x 2", rear (6 cylinder). Discs, front 10" x 2 1/2", rear (V-8's). Hydraulic, self-adjusting. Parking brake is foot-operated, hand-released. Dual braking system. Electrical: Alternator, 34-amp on 6's. 41-amp on V-8's. Transistorized voltage regulator. Electronic ignition system. Interior Features: All-vinyl bench seats (standard Dart sedan and Swinger). Cloth and vinyl on Custom, Swinger Special and Sport models. Optional bucket seats on Sport only. Center armrest bench seats optional on all models. Cigar lighter (optional on Sport). Deep-pile carpeting (Sport). 3-spoke steering wheel with horn bars (standard Dart Custom and Swinger), horn button on others. Simulated wood-grained instrument panel (Sport). Keyless door locking system. Dome light. Heater/Defroster. 2-speed windshield wipers. Exterior Features: Body side and rear deck panel stripes. (Sport 340). Bright drain-trough mouldings (Custom 4-door sedan, Swinger and Sport 340). Wheel-lip mouldings (standard Sport).

## DIMENSIONS

### MONACO/POLARA

Wheelbase 122.0"	Rear Track 63.4"
Overall Length 226.6"	Front Headroom 38.8"
Overall Height 56.1"	Front Legroom 41.8"
Overall Width 79.6"	Rear Headroom 38.4"
Front Track 62.1"	Rear Legroom 39.1"

(Based on 4-door sedan)

### CORONET

Wheelbase 118.0"	Rear Track 62.0"
Overall Length 212.9"	Front Headroom 38.5"
Overall Height 53.6"	Front Legroom 42.2"
Overall Width 77.8"	Rear Headroom 37.3"
Front Track 61.9"	Rear Legroom 36.7"

(Based on 4-door sedan)

### CHARGER

Wheelbase 115.0"	Rear Track 62.0"
Overall Length 212.7"	Front Headroom 37.3"
Overall Height 52.2"	Front Legroom 42.2"
Overall Width 77.0"	Rear Headroom 36.4"
Front Track 61.9"	Rear Legroom 34.1"

### CHALLENGER

Wheelbase 110.0"	Rear Track 60.7"
Overall Length 198.2"	Front Headroom 37.4"
Overall Height 51.0"	Front Legroom 42.3"
Overall Width 76.4"	Rear Headroom 35.6"
Front Track 60.2"	Rear Legroom 30.9"

### DART SEDAN

	HARDTOP	SPORT
Wheelbase 111.0"	111.0"	108.0"
Overall Length 203.8"	203.8"	200.0"
Overall Height 54.1"	52.8"	53.0"
Overall Width 69.6"	69.6"	71.7"
Front Headroom 38.7"	37.6"	37.5"
Rear Headroom 37.3"	36.7"	36.5"
Rear Legroom 35.9"	31.9"	29.9"
Front Legroom 41.5"; Track-Rear 55.6"; Front 59.1"		

All product illustrations and specifications are based on authorized information. Although descriptions are believed correct at time of publication, accuracy cannot be guaranteed. Some equipment shown on product illustrations is optional, at extra cost. Chrysler International S.A. reserves the right to make changes from time to time in specifications, colors, materials, prices or models without notice or obligation.

Code YTSFI

Printed in Canada

