



CORONET CRESTWOOD WAGON

# 1973 DODGE WAGONS



POLARA CUSTOM WAGON & MONACO WAGON

# WHEN IT COMES TO FUNCTIONAL FEATURES, DODGE

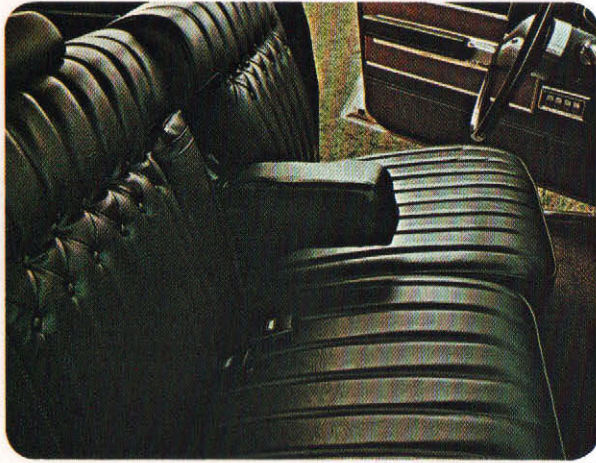

Looking for something more than a large cargo area? Check out a Monaco interior. Monaco's all-vinyl seats and center armrest are typical of the luxurious touches you'd expect to find in one of America's best-looking full-sized station wagons.



Odds and ends shouldn't get in the way of the big load. All Dodge wagons have convenient storage compartments located over the rear wheel wells. And if you order a two-seat wagon, we'll throw in an additional concealed storage compartment in the cargo floor.



Here's a "two-way" tailgate that actually opens three ways—to the side, with the window *up* or *down*, or flat down to give you a loading platform. A nice approach for a highly functional "fifth door."



Optional dual air conditioning and an efficient rear-window air deflector that's standard on most models are two examples of the Dodge approach to station wagons.

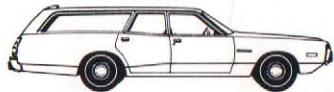

CORONET 4-DOOR WAGON

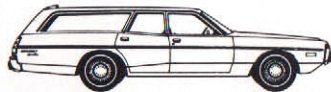

CORONET CUSTOM 4-DOOR WAGON



CORONET CRESTWOOD 4-DOOR WAGON

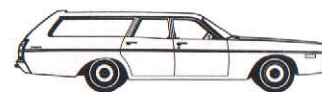

POLARA 4-DOOR WAGON

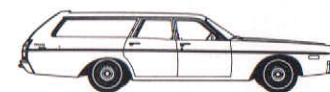

POLARA CUSTOM 4-DOOR WAGON



MONACO

## DODGE SPORTSMAN—A DIFFERENT APPROACH THAT'S CATCHING ON FAST.

It may not resemble a traditional station wagon, but a Dodge Sportsman is still one of the best ways imaginable to haul more stuff (and people) with less crowding. On-the-job, around-the-neighborhood, or at-the-campgrounds, the Sportsman has become one of the two most popular wagons of its kind in America. In brief, you'll find Sportsman has a passenger-car-approach to suspension and driver controls, standard front disc brakes, seating capacity for up to fifteen friends, and a complete range of options—including air conditioning, automatic speed control, and an AM/FM radio. There's a lot more to consider, too. Ask your Dealer for a Sportsman catalog, and, by all means, test-drive a 1973 Sportsman. It'll open your eyes.

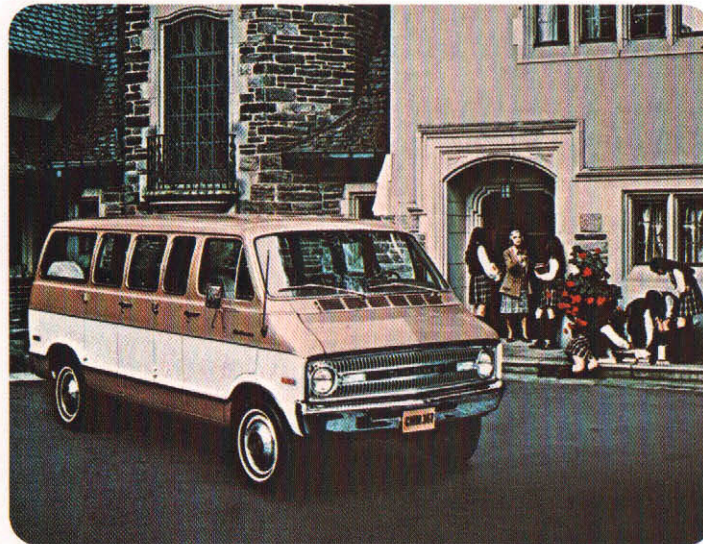

Royal Sportsman

## TOWING A

Dodge, a leader in the field of recreational vehicles, also offers completely engineered station wagons that are specially equipped for trailer towing. This year, Dodge offers one of the most complete trailer-towing packages in the industry, starting out with a dependable Dodge wagon built around the strength of Unibody construction, and finishing off with a package of all the items you'll need for safe, efficient trailer-towing. Coronet wagons can safely pull trailers weighing up to 6,000 pounds, and Polara/Monaco wagons can safely handle trailers weighing up to 7,000 pounds.

### DODGE'S TRAILER-TOWING PACKAGE INCLUDES THE FOLLOWING ITEMS:

- Trailer-wiring harness
- Heavy-duty suspension system

# HAS THE WAGONS COVERED.



Coronet's back with the same great extra-room story. Here's an intermediate-sized wagon that gives you a flat, four-by-eight-foot cargo area. Now you know how you're going to get those paneling sections home!

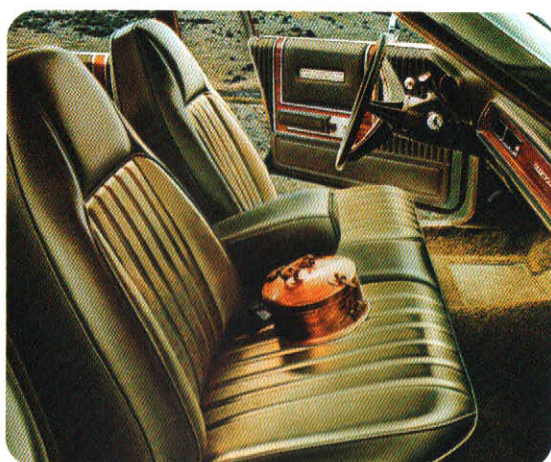

Take an "inner space" trip in a 1973 Coronet wagon. It's the best way to appreciate Coronet's roomy atmosphere, comfortable seats, and the silence of Torsion-Quiet Ride.

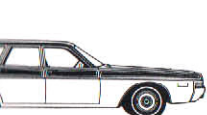

4-DOOR WAGON



SPORTSMAN 109" WB



SPORTSMAN 127" WB



SPORTSMAN 127" MAXIWAGON

## TRAILER? DODGE IS READY WHEN YOU ARE.

- High-capacity radiator
- Fan shroud
- Coolant reserve system
- Variable-load turn signal flasher
- 60-amp heavy-duty Chrysler alternator
- Heavy-duty rear axle
- Extra-wide wheel rims
- Auxiliary transmission oil cooler

### ADDITIONAL REQUIRED EQUIPMENT:

In order to ensure safe, efficient trailer-towing operations, an optional automatic transmission is required on all Coronet wagons equipped for trailer-towing. Optional L84 x 15 tires are required equipment on all Polara/Monaco 2-seat wagons equipped for trailer-towing. (These tires are standard on Polara/Monaco 3-seat wagons.)

### OTHER PACKAGES:

In addition to the Trailer-Towing Package, a Trailer Wiring Package is available for those drivers who intend to pull only extremely light trailers. A Heavy-Duty Package is available for owners who intend to do a lot of long-distance driving. See the Optional Packages section on the back cover for a list of the items included in these packages.

A special Trailer-Towing Package is also available on all 1973 Sportsman models. See the Sportsman catalog for further information, or ask your Dealer for more details on the Sportsman Trailer-Towing Package.

Many Dealers are also equipped to install a trailer tow bar on your new Dodge. Your local Dodge Dealer can supply information as to whether or not he provides this service.

### CORONET WAGON STANDARD EQUIPMENT

|                    |   |
|--------------------|---|
| ENGINE:            | 318 V8  |
| TRANSMISSION:      | 3-speed manual, column-mounted shift  |
| SUSPENSION:        | Front: Torsion bars with sway bar<br>Rear: Asymmetrical leaf springs  |
| TIRES & WHEELS:    | H78 x 14 BSW tires; 14 x 5.5 wheels   |
| BRAKES:            | Front: Power disc; rear: 11" x 2½" drum   |
| ELECTRICAL SYSTEM: | Battery: 280-ampere (46-amp-hr)<br>Alternator: 41 amp<br>Electronic Ignition System<br>Transistorized voltage regulator |
| FUEL TANK:         | 21 gallons  |
| CARGO VOLUME:      | 91.3 cu. ft.  |

### POLARA/MONACO WAGON STANDARD EQUIPMENT

|                    |   |
|--------------------|---|
| ENGINE:            | 360 V8  |
| TRANSMISSION:      | TorqueFlite 3-speed automatic   |
| SUSPENSION:        | Torsion-Quiet Ride; torsion bars in front<br>Asymmetrical leaf springs in the rear  |
| TIRES:             | J78 x 15 BSW (2-seat wagons)<br>L84 x 15 BSW (3-seat wagons)  |
| WHEELS:            | 15 x 6.5  |
| BRAKES:            | Front: Power disc; rear: 11" x 2½" drum   |
| AXLE RATIOS:       | 2.76:1 (Opt. Sure Grip 2.76, 3.23)  |
| ELECTRICAL SYSTEM: | Battery: Polara: 280-ampere (46-amp-hr)<br>Monaco: 315-ampere (55-amp-hr)<br>Alternator: 41-amp<br>Electronic Ignition System<br>High-speed starter<br>Transistorized voltage regulator |
| FUEL TANK:         | 23 gallons  |
| CARGO VOLUME:      | 104.2 cu. ft.   |

### SPORTSMAN STANDARD EQUIPMENT

|                    |   |
|--------------------|---|
| ENGINES:           | 225 Six, 318 V8   |
| TRANSMISSION:      | 3-speed manual  |
| SUSPENSION:        | Front: Coil springs; rear: leaf springs   |
| TIRES:             | G78 x 15-B  |
| WHEELS:            | 15 x 5.5  |
| BRAKES:            | Front: Manual disc; rear: 10" x 2½" drum  |
| AXLE RATIOS:       | 3.55:1 (std. Six), 3.23:1 (std. V8)   |
| ELECTRICAL SYSTEM: | Battery: 280-ampere (46-amp-hr)<br>Alternator: 37-amp<br>Transistorized voltage regulator |
| FUEL TANK:         | 25 gallons  |

\*B200 Sportsman dimensions based on 127"-wheelbase. Sportsman is also available in a 109"-wheelbase and a 127"-wheelbase Maxiwagon.

## STANDARD SPECIFICATIONS

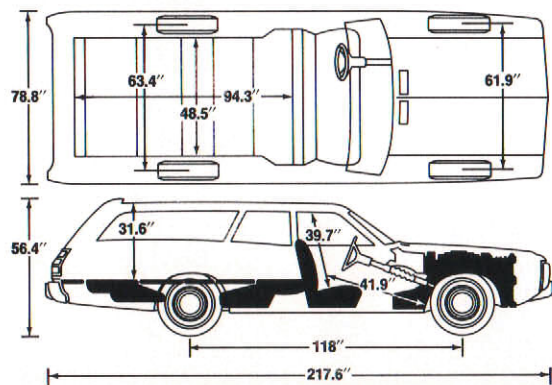

## STANDARD SPECIFICATIONS

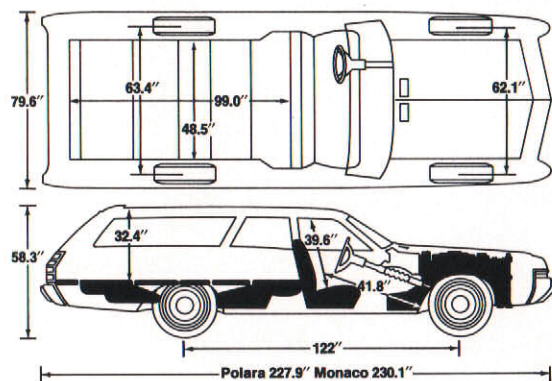

## STANDARD SPECIFICATIONS\*

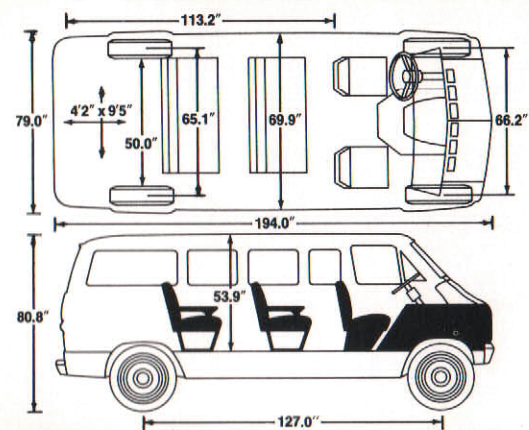

## STANDARD EQUIPMENT

### INTERIOR FEATURES

All-vinyl front bench seat, available in Blue, Green, and Black (Coronet), Blue, Green, Black, Gold, Tan (Coronet Custom), or in Green, Black, and Gold (Polara), and Green, Parchment, Black, and Gold (Polara Custom)

All-vinyl split-back front bench seat with center armrest, available in Blue, Green, Parchment, Black, and Gold (Monaco), and Blue, Green, Black, Gold, Tan (Coronet Crestwood)

Ventless side windows

Keyless door-locking system

3-spoke color-keyed steering wheel with simulated wood-grained insert (wood-grained insert NA on Coronet or Polara)

Color-keyed carpeting (except Coronet)

Heater/defroster with 3-speed blower fan

Inside hood release (Polara/Monaco)

Cargo compartment carpeting (except Coronet, Coronet Custom, and Polara)

Manual tailgate lock (std. on all 2- and 3-seat wagons)

Tailgate Auto-Lock (std. on Coronet Crestwood and all 3-seat wagons)

Power tailgate door and window (Polara, Polara Custom, and Monaco)

Simulated wood-grained door trim inserts (wood-grained insert NA on Coronet or Polara)

Dome light with front door courtesy light switch

Glove box lock

Front and rear armrests

Front and rear ashtrays

Cigarette lighter

Cargo compartment light (std. on 3-seat wagons and all Monaco wagons)

Rallye Instrument Panel (Coronet Crestwood)

Power steering (Polara, Polara Custom, and Monaco)

Electric clock (Monaco)

"Headlight-on" warning buzzer (Monaco)

Rear door light switch (Monaco)

Glove box light (Monaco)

Map/dome light (Monaco)

Ashtray light (Monaco)

### EXTERIOR FEATURES

Dual horns (except Coronet)

Roof air deflector (all except Coronet and Coronet Custom)

Front sway bar on std. suspension system

2-speed electric windshield wipers

Electric windshield washers

Body side moulding with vinyl insert (except Coronet and Coronet Custom)

Bright mouldings on upper and lower tailgate door (Coronet Custom and Crestwood)

Simulated wood-grained body side applique (Monaco and Crestwood)

Concealed headlights (Monaco)

### SAFETY FEATURES

Cleaner Air System with Vapor Saver (gasoline evaporation control system)

Antitheft steering column lock

Backup lights

Breakaway front ashtray

Combination side markers, light reflectors

Dual Braking System

Extra-protection bumper system

Energy-absorbing steering column and steering wheel

Flush outside door handles

3-point safety belt system with locking retractors

Hazard warning system

Head restraints

"Key-left-in-ignition" warning buzzer

Left outside mirror

Inside day/night rearview mirror with double-ball-joint safety mount

Nonoverride door locks, except on driver's door

Padded instrument panel and sun visors

Parking brake

Parking brake and master cylinder warning light

Safety-Action inside door handles

Safety-Rim wheels

Soft knobs on window cranks

Turn signals with lane-change feature

Windshield wipers and washers

# 1973 DODGE WAGONS

## DODGE WAGON SELECTED OPTIONS

400 2-bbl. V8 engine  
 400 4-bbl. V8 engine with dual exhausts (except Polara/Monaco)  
 440 4-bbl. V8 engine (except Coronet)  
 Air conditioning  
 Dual air conditioning (Polara, Polara Custom, Monaco)  
 Electric clock (std. on Monaco)  
 Sure Grip differential  
 Emission Control Package (mandatory on all wagons registered in Calif.)  
 Carpeted cargo compartment floor (std. on Coronet Crestwood, Polara Custom, and Monaco)  
 Concealed, lockable storage compartment (std. on Polara Custom and Monaco)  
 Tinted glass, all windows  
 Inside hood release (std. on Polara, Polara Custom, and Monaco)  
 Dual horns (std. on all models except Coronet)  
 Luggage rack  
 Cornering lights (on Polara, Polara Custom, and Monaco)  
 Outside left remote-control mirror and outside right mirror  
 Power steering (std. on Polara, Polara Custom, and Monaco)  
 Power windows  
 Power tailgate window (std. on Polara, Polara Custom, and Monaco)  
 Music Master AM radio  
 AM/FM monaural radio  
 AM radio with stereo tape cassette (Polara, Polara Custom, and Monaco)  
 AM/FM multiplex stereo radio  
 AM/FM multiplex stereo radio with cassette  
 Single rear seat speaker (std. with stereo on Coronet; NA with stereo on Polara, Polara Custom, and Monaco)  
 Dual rear seat speakers (available with stereo only, on Polara, Polara Custom, and Monaco)  
 Rear window cleaning vane (available as an option on Coronet and Coronet Custom; std. on Coronet Crestwood and Polara, Polara Custom, and Monaco)

All-vinyl split-back front bench seat with center armrest, available in Blue, Green, Parchment, Black, and Gold (Polara Custom)  
 All-vinyl 50/50 front bench seat, with passenger recliner, available in Green and Parchment (Monaco)  
 Deluxe 3-spoke steering wheel with horn bars and a simulated wood-grained insert (std. on Polara Custom and Monaco)  
 "Tuff" steering wheel (Coronet models only; requires power steering)  
 Tilt "Rim Blow" steering wheel (Polara, Polara Custom, and Monaco)  
 Heavy-duty shocks (Polara, Polara Custom, and Monaco)  
 TorqueLite 3-spd. automatic transmission (std. on Polara, Polara Custom, and Monaco)  
 Upper level ventilation (except with air conditioning)  
 Undercoating and hood insulator pad  
 Vent windows (Polara, Polara Custom, and Monaco)  
 Deluxe wheel covers (std. on Monaco)  
 Premier wheel covers (Polara, Polara Custom, and Monaco)  
 Wire wheel covers (Coronet models)  
 Rallye road wheels with chrome trim ring (Coronet models)  
 Magnum wheels with chrome trim ring (Coronet models)

### OPTIONAL PACKAGES

Coronet Light Package. (Includes fender-mounted turn signals, a map and courtesy light, ashtray and glove box lights, a cargo compartment light, a rear dome light switch, a "headlight-on" warning buzzer, and an ignition switch light with time delay.)  
 Polara/Monaco Light Package. (Includes fender-mounted turn signals, an instrument panel courtesy light, an instrument panel flood light with ignition light time delay, a "Low Fuel" indicator

light, and a "Lock Door" reminder light, plus the following items that are standard on all Monaco models: ashtray and glove-box lights, a map/dome light, a cargo compartment light, a rear door light switch, and a "headlight-on" warning buzzer.)  
 Coronet E-Z Order Package. (This package is available on Coronet Custom and Crestwood wagons. It includes the following items: an automatic transmission, power steering, an AM radio, an outside left remote-control mirror, deluxe wheel covers, an inside hood release, the Coronet Light Package listed left, 3-speed windshield wipers, deluxe bumper guards, undercoating and a hood insulator pad, whitewall tires, and a roof luggage rack.)  
 Polara/Monaco E-Z Order Package. (This package is available on Polara Custom and Monaco, and consists of the following items: a roof luggage rack, AM radio, a rear seat speaker, whitewall tires, deluxe wheel covers on the Polara Custom and premier wheel covers on the Monaco, an electric clock, the Polara/Monaco Light Package listed above, an outside left-remote-control mirror, 3-speed windshield wipers, and undercoating and a hood insulator pad.)  
 Heavy-Duty Package. (Includes a heavy-duty suspension, extra-wide wheel rims, and a maximum cooling system consisting of a

high-capacity radiator, a coolant reserve system, and a fan shroud.)  
 Trailer Wiring Package. (Includes a 7-wire trailer wiring harness, a variable-load turn signal flasher, and Chrysler's 60-amp heavy-duty alternator.)  
 Trailer-Towing Package. (Includes the items listed under the Heavy-Duty and Trailer Wiring Packages, a heavy-duty 3.23:1 axle ratio, and an auxiliary transmission oil cooler. This package requires an automatic transmission on all Coronet wagons. Size L84 x 15 tires are required on all Polara and Monaco wagons equipped with this package.)  
 Coronet Luxury Equipment Package. (This package is available on Coronet Custom and Coronet Crestwood wagons, and includes the following equipment: air conditioning, tinted glass, an electric clock, vinyl body side mouldings, a power tailgate, power windows, an AM/FM radio, a rear seat speaker, a rear window defogger on Coronet Custom, a vinyl center armrest seat, upper door mouldings, and the additional equipment listed in the Coronet E-Z Order Package.)  
 Polara/Monaco Luxury Equipment Package. (This package is available on all Polara Custom and Monaco wagons. It consists of the following equipment: a 50/50 vinyl seat with passenger recliner (Monaco), air conditioning, tinted

glass, an AM/FM radio, power windows, a power seat, power door locks, an Auto-Lock tailgate, manual vent windows, an outside right mirror, sill mouldings, assist handles, and the additional equipment listed under the Polara/Monaco E-Z Order Package.)

### EXTERIOR COLORS

Light Blue—HB1.  
 Bright Blue Metallic—GB5.  
 Bright Red—FE5.  
 Light Gold—JY3.  
 Gold Metallic—JY6.  
 Dark Gold Metallic—JY9.  
 Pale Green—JF1.  
 Light Green Metallic—GF3.  
 Dark Green Metallic—JF8.  
 Parchment—HL4.  
 Dark Silver Metallic—JA5.  
 Eggshell White—EW1.  
 Black—TX9.  
 Super Blue (Coronets)—TB3.  
 Top Banana (Coronets)—FY1 (extra-cost).  
 Bronze Metallic (Coronets)—GK6.  
 Medium Tan Metallic (Coronets)—HT6.  
 Dark Blue Metallic (Polara/Monaco)—JB9.  
 Turquoise Metallic (Polara/Monaco)—FQ5.  
 Yellow (Polara/Monaco)—DY2.  
 Dark Tan (Polara/Monaco)—HT8.



Extra care in engineering makes a difference in Dodge...depend on it.



All product illustrations and specifications are based on authorized information. Although all descriptions are believed correct at publication approval, accuracy cannot be guaranteed. Some of the equipment shown on product illustrations is optional at extra cost. Dodge Division reserves the right to make changes from time to time, without notice or obligation, in prices, specifications, colors and materials, and to change or discontinue models.

FORM NO. 81-205-3250.

LITHO IN U.S.A. 8/72.

