

1974 DODGE

Tradesman Vans

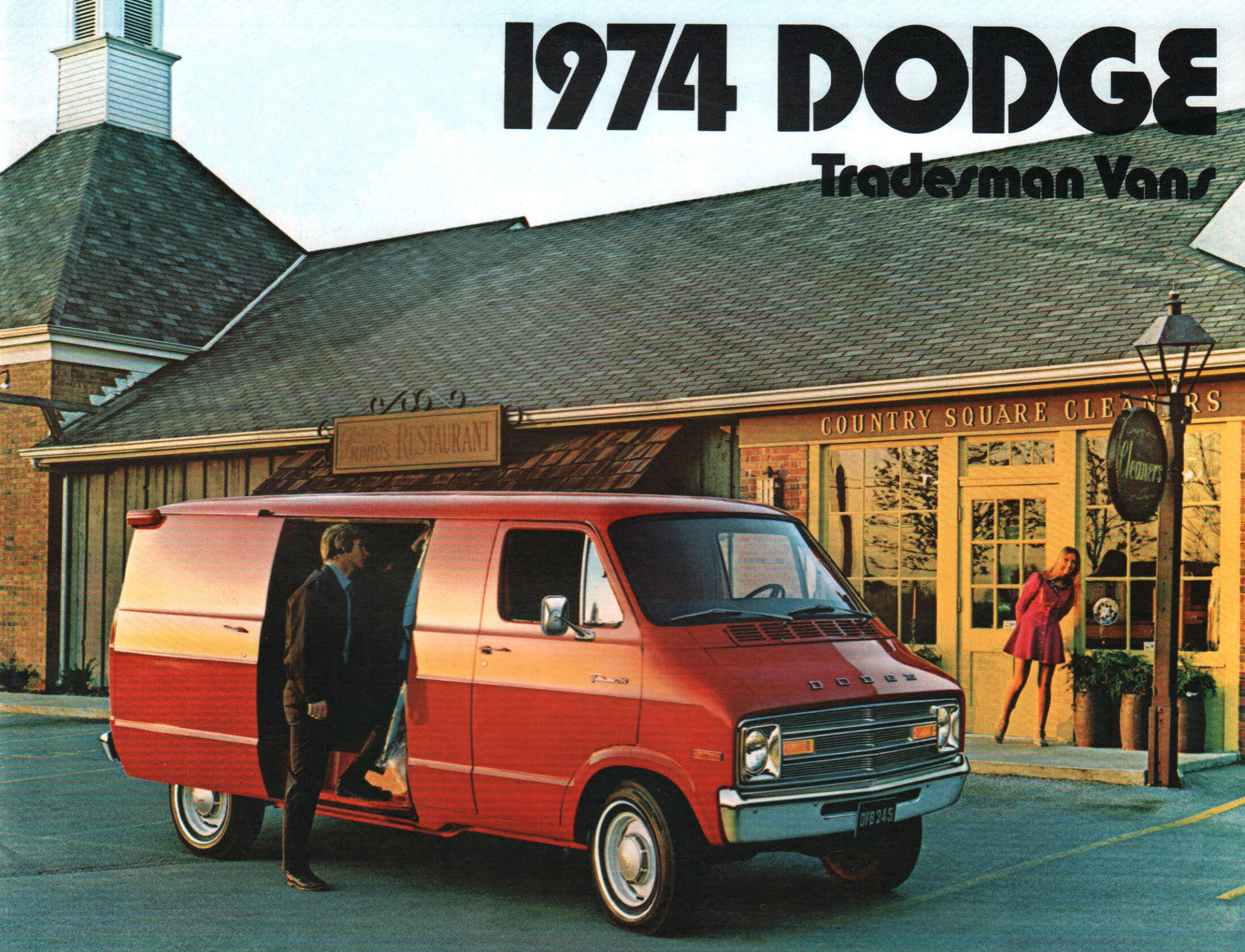

DODGE TRADESMAN VAN

Dodge's Best Seller!

Dodge has been in the truck building business for over half a century and has maintained its high position and good reputation by constantly coming up with new ideas, innovations, and improvements to suit a need or solve a problem.

Dodge is well-known as a builder of dependable trucks. There are several things that have contributed to this dependability. ELECTRONIC TESTING of engines and engine parts to be sure they function properly before the truck leaves the plant. The ELECTRONIC IGNITION SYSTEM,* standard on all Dodge trucks, has no points or condenser. This means service on these components is eliminated. A solid-state VOLTAGE REGULATOR has no moving parts to go out of adjustment. Dependability is also found in the Dodge Truck transmission. The LOADFLITE AUTOMATIC TRANSMISSION has been constantly refined and improved to the point where we feel it is one of the best on the road today. These are the things that help make a Dodge truck dependable.

One of the most popular and successful truck models Dodge has ever developed is the Dodge Tradesman van, affectionately (and with good reason) referred to as the Dodge Strong Box.

The Tradesman van offers a combination of features you can't get on any other compact van. And one of its models, and the senior member of the compact van family, is the Dodge Maxivan. It's the largest compact van built in America, with a 127-inch wheelbase and 18 inches added to the rear.

As you look through this catalog and read about the many carlike features the Tradesman van offers, you'll soon see why it's the best-selling truck in Dodge history. Now turn the page and see what's new in compact vans for 1974.

*Not available on diesel engines.

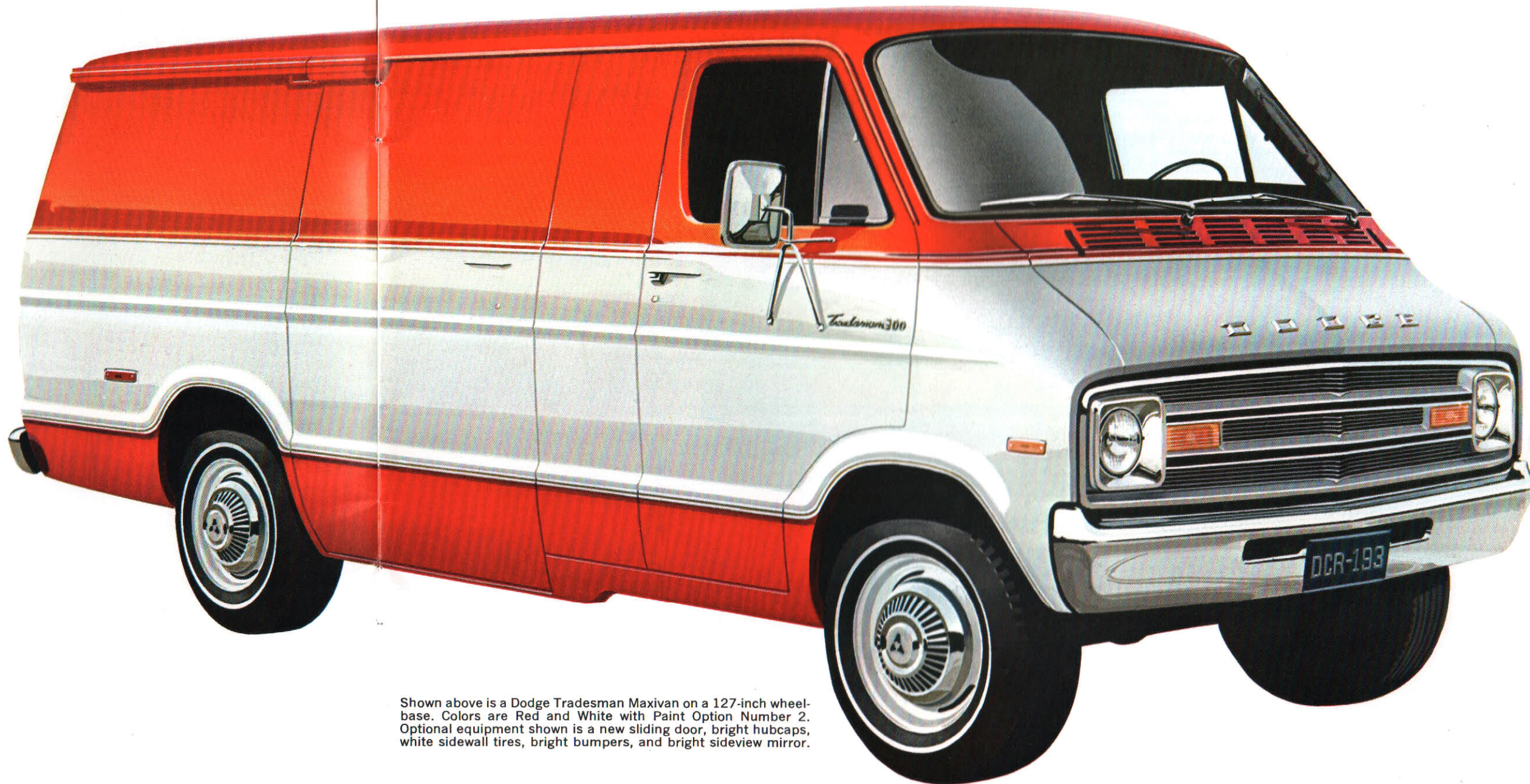

Shown above is a Dodge Tradesman Maxivan on a 127-inch wheelbase. Colors are Red and White with Paint Option Number 2. Optional equipment shown is a new sliding door, bright hubcaps, white sidewall tires, bright bumpers, and bright sideview mirror.

EXTRA CARE IN ENGINEERING MAKES A DIFFERENCE IN DODGE.

THE LIVING IS EASY.

Dodge Strong Box knows how to please the driver.

POWER STEERING is an option you'll want on your truck because it makes driving with a heavy load so much easier. Available on all Strong Box models.



AIR INTAKE vents are located at a high level so cooler, cleaner air is brought into the driver/passenger compartment.

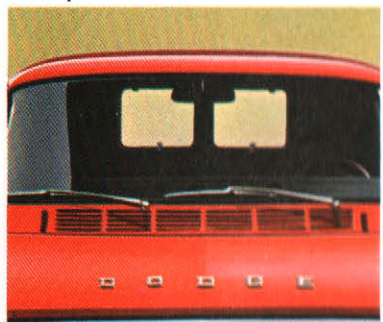

DUAL BRAKE SYSTEM consists of fade-resistant front disc brakes and dependable drum-type rear brakes. They each have a separate brake fluid chamber in the master cylinder and work simultaneously when brakes are applied. Should one fail, the other would not be affected.



LARGE WINDSHIELD WIPER PATTERN clears windshield from post to post and gives the driver a good view of the road in rain or snow.

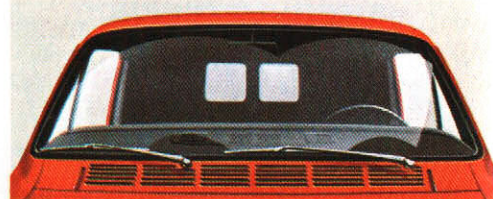

THE SERVICING IS EASY.

All areas requiring service are easily accessible.

WIND-TUNNEL SHAPE reduces windsway effect. This in turn makes the van easy to handle and stable on the open highway.



WHEELBASES on the Dodge Strong Box are 109 inches and 127 inches. The 127-inch is the longest of any compact on the road, yet this van has a short turning radius.

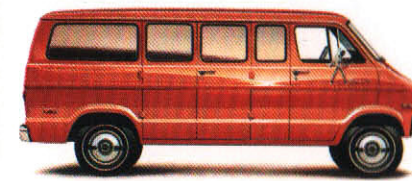

THE LOADING IS EASY.

When loading is made quick and convenient, the work load is not as tiring.

THE OPTIONAL FRONT PASSENGER SEAT of the 127-inch-wheelbase model does not protrude into the side door entrance, thereby giving full door width access to cargo area when loading and unloading.



NEW SLIDING DOOR is available on all 127-inch-wheelbase Tradesman vans. Traverses smoothly on sturdy guide rail. Gives you double-door opening access with a movement of your hand.

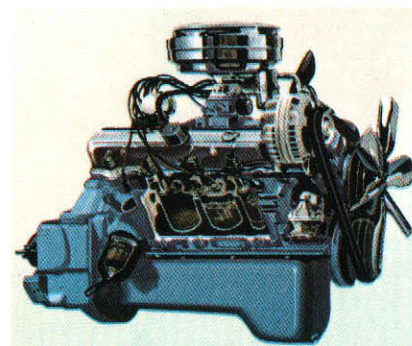

ENGINE CHOICES—The standard engines offered in 1974 Dodge Van's are the spirited 225-cubic-inch Slant Six or the 318 V8. The 360-cubic-inch V8 is also available as an option. All run on regular or low-lead gasoline.



FRONT DOORS AND DOOR-STEPS are extra wide to make it easier for driver to get in and out. A welcome convenience feature for deliverymen.



FULL-WIDTH SUN VISORS extend all the way to the windshield corners to help keep the sun's rays out of the driver's eyes. A visor for the passenger side is included when passenger seat is ordered.



CARLIKE SEATS for driver and passenger comfort are all-vinyl full-foam and twenty inches wide with square corners for leg support. Color selection includes green, parchment, black, and blue.



AUTOMATIC TRANSMISSION is available as an option on all standard and optional engines. A convenience item that makes driving throughout an eight-hour day so much easier.



AIR CONDITIONING is an option that either recirculates air or takes in fresh air from the outside and cools it. Some systems only cool the inside air.



INSTRUMENT PANEL is designed like the kind you'd find on a passenger car. The instrument panel pad is new for 1974. All controls are easy to reach and dials are easy to read.

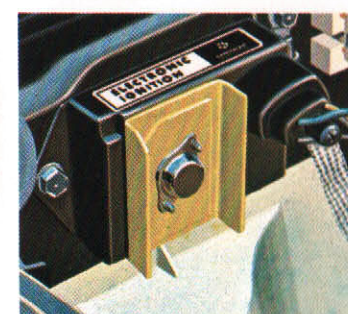

ELECTRONIC IGNITION SYSTEM eliminates breaker points and condenser, and excluding the spark plugs, gives you an almost maintenance-free ignition system.

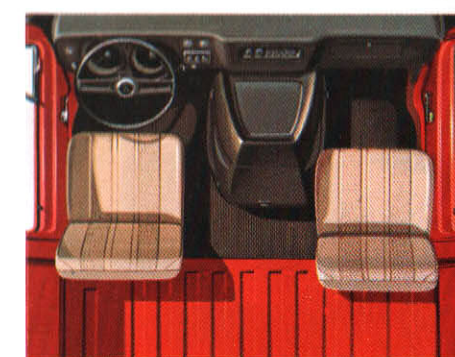

FLOOR SPACE from the rear of the engine cover to the rear door measures over 11 feet (12 $\frac{3}{4}$ feet in the Maxivan). Lets you carry carpeting, ladders, and other such items and still close the rear doors.



CONCEALED SIDE CARGO STEP is protected from snow and ice by the side door. Less likelihood of slipping and falling on collected snow on step.

EXTRA CARE IN ENGINEERING MAKES A DIFFERENCE IN DODGE.

THE DRIVING IS EASY.

Dodge has dozens of comfort and convenience items to make your daily driving a pleasure.

EASY ACCESS to the cargo and passenger compartments is made possible by the low, short engine cover.



RUST PROTECTION for many body parts is provided by galvanized coatings. The parts shown in red are those most exposed to moisture, road salt, and other damaging elements.

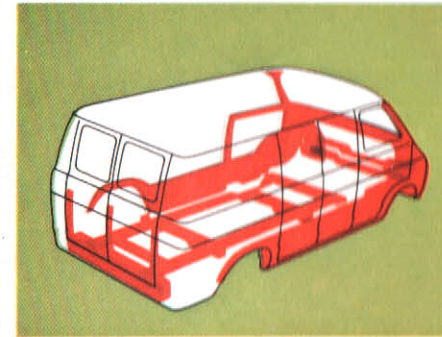

THE HEATER is located in the engine compartment. It's out of the way, makes the driver and passenger compartment quieter, and gives you more legroom.



LARGE HOOD OPENING means you get into the front of the engine compartment without a struggle. Dipstick, battery, and radiator are right there in front of you, easy to reach.

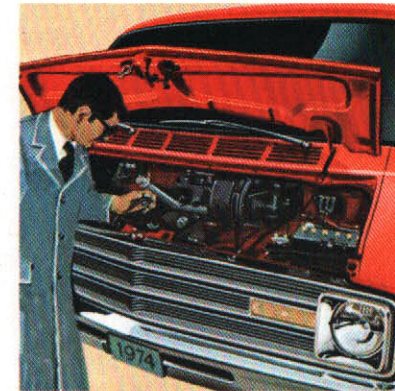

ENGINE REMOVAL, should it be necessary, is done through the front, not through the passenger compartment as is the case with some vans.

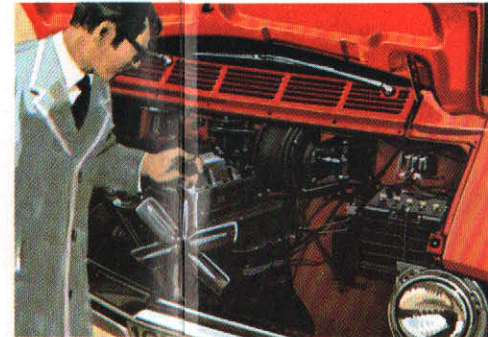

ANTISPIN DIFFERENTIAL gets you out of situations where one rear wheel is slipping in mud or snow by transferring power to the other rear wheel.

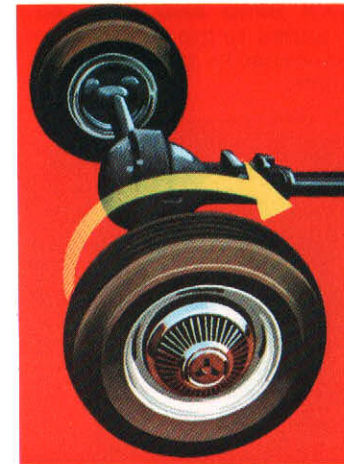

HEAVY-DUTY ALTERNATOR when extra electrical power is needed such as in trailer towing.



AUXILIARY HEATER for giving extra heat to the rear compartment if required. (A 50-amp alternator must also be ordered.)



BRIGHT-FINISH WHEEL COVERS give a little extra sparkle and beauty to your Tradesman van. (B100 and B200 only.)

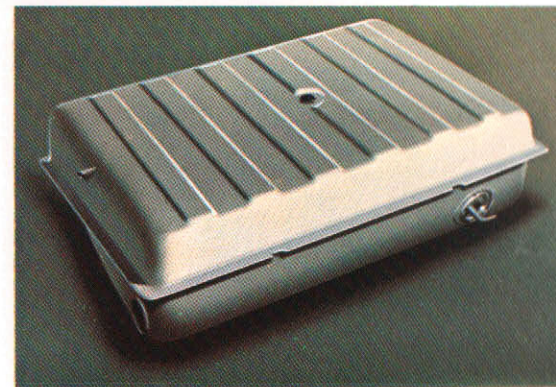
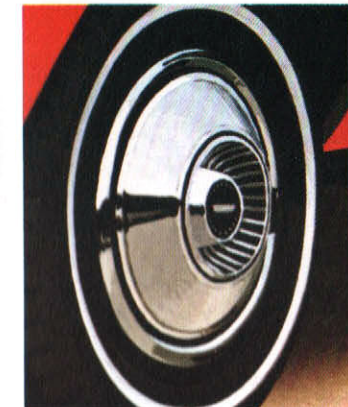

A LARGE FUEL TANK, 23-gallon-capacity, reduces fuel stops and gives a better feeling of security when driving through sparsely settled areas.

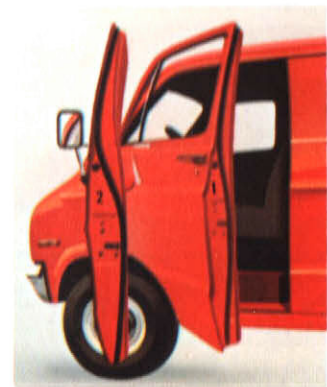

TWO-STAGE front door checks hold the doors at half-open or fully open. No more doors closing when you don't want them to.

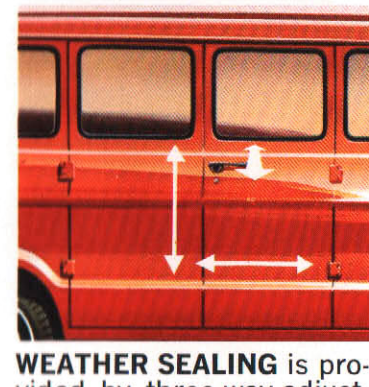

WEATHER SEALING is provided by three-way-adjustable cargo doors. This helps prevent annoying wind noise and water from getting into the cargo area.



THE ENGINE COVER is made of durable fiber glass. It reduces heat and noise, but is cool to the touch. It can be quickly removed and taken out through either front door.

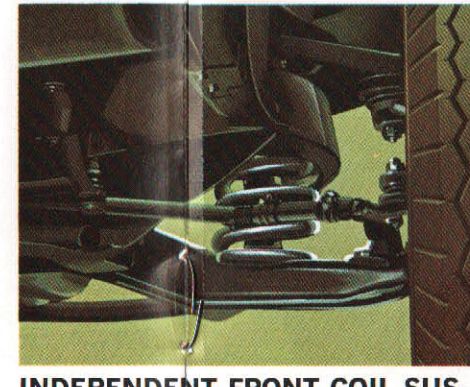

INDEPENDENT FRONT COIL SUSPENSION can be positively aligned on standard passenger-car equipment, quickly and inexpensively.

POPULAR OPTIONS.

Give your Strong Box a personal touch by selecting the equipment that suits the needs of your particular profession.



DECA-MATE gives you the opportunity to give your Tradesman van a personal touch in color and design. (Dealer-installed option)



PAINTED OR BRIGHT LOW-MOUNT MIRRORS let you tell at a glance what the traffic situation is on either side.

OPTIONAL EQUIPMENT NOT SHOWN

- Heavy-duty battery
- Vacuum booster brake (B100 only)
- Bright front and rear bumpers
- Cigarette lighter
- 360 V8 engine
- Tinted glass
- Lighted glove box
- Dual electric horns
- Outside mouldings
- Convenience package
- Insulation package
- Trailer-towing package
- Deluxe bucket seats
- Heavy-duty shock absorbers
- Heavy-duty front and rear springs
- Inside hood release
- Padded instrument panel

EXTRA CARE IN ENGINEERING MAKES A DIFFERENCE IN DODGE.

TRADESMAN MODELS

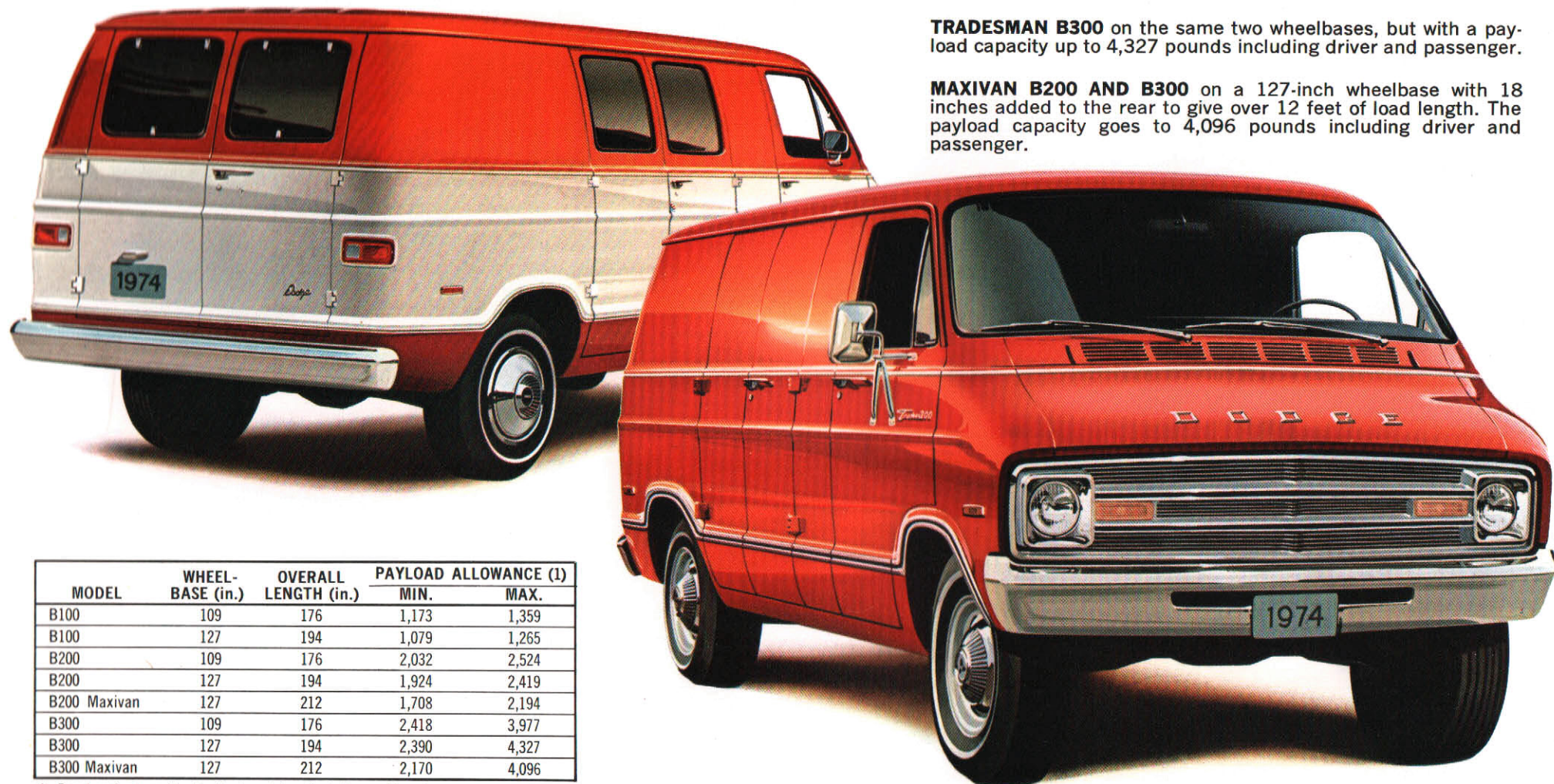

TRADESMAN B100 on 109- and 127-inch wheelbases with a payload capacity up to 1,359 pounds including driver and passenger.

TRADESMAN B200 on 109- and 127-inch wheelbases, payloads to 2,524 pounds including driver and passenger. With higher capacity springs and axles than the B100.

TRADESMAN B300 on the same two wheelbases, but with a payload capacity up to 4,327 pounds including driver and passenger.

MAXIVAN B200 AND B300 on a 127-inch wheelbase with 18 inches added to the rear to give over 12 feet of load length. The payload capacity goes to 4,096 pounds including driver and passenger.

MODEL	WHEEL-BASE (in.)	OVERALL LENGTH (in.)	PAYLOAD ALLOWANCE (1)	
			MIN.	MAX.
B100	109	176	1,173	1,359
B100	127	194	1,079	1,265
B200	109	176	2,032	2,524
B200	127	194	1,924	2,419
B200 Maxivan	127	212	1,708	2,194
B300	109	176	2,418	3,977
B300	127	194	2,390	4,327
B300 Maxivan	127	212	2,170	4,096

(1) Based on 6-cyl. models. For 8-cyl. models, refer to the model section. Payloads include driver and passenger.

Side and rear-door windows (as shown at left) are optional at extra cost. Paint options include the two-tone shown here. Your Dodge Dealer will be happy to show you the many color and window options you may choose from.

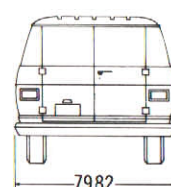
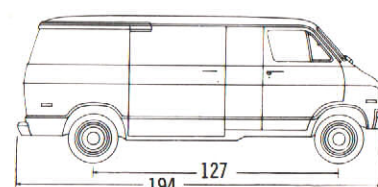
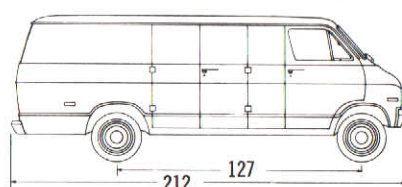
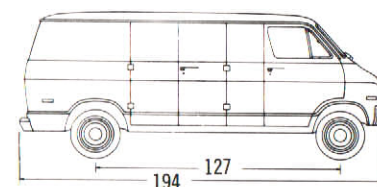
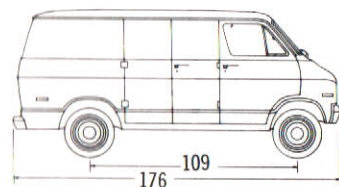

The sliding door option shown on the above model is available on a 127" WB and also on the Maxivan.

1974 DODGE CB300 HARY VAN

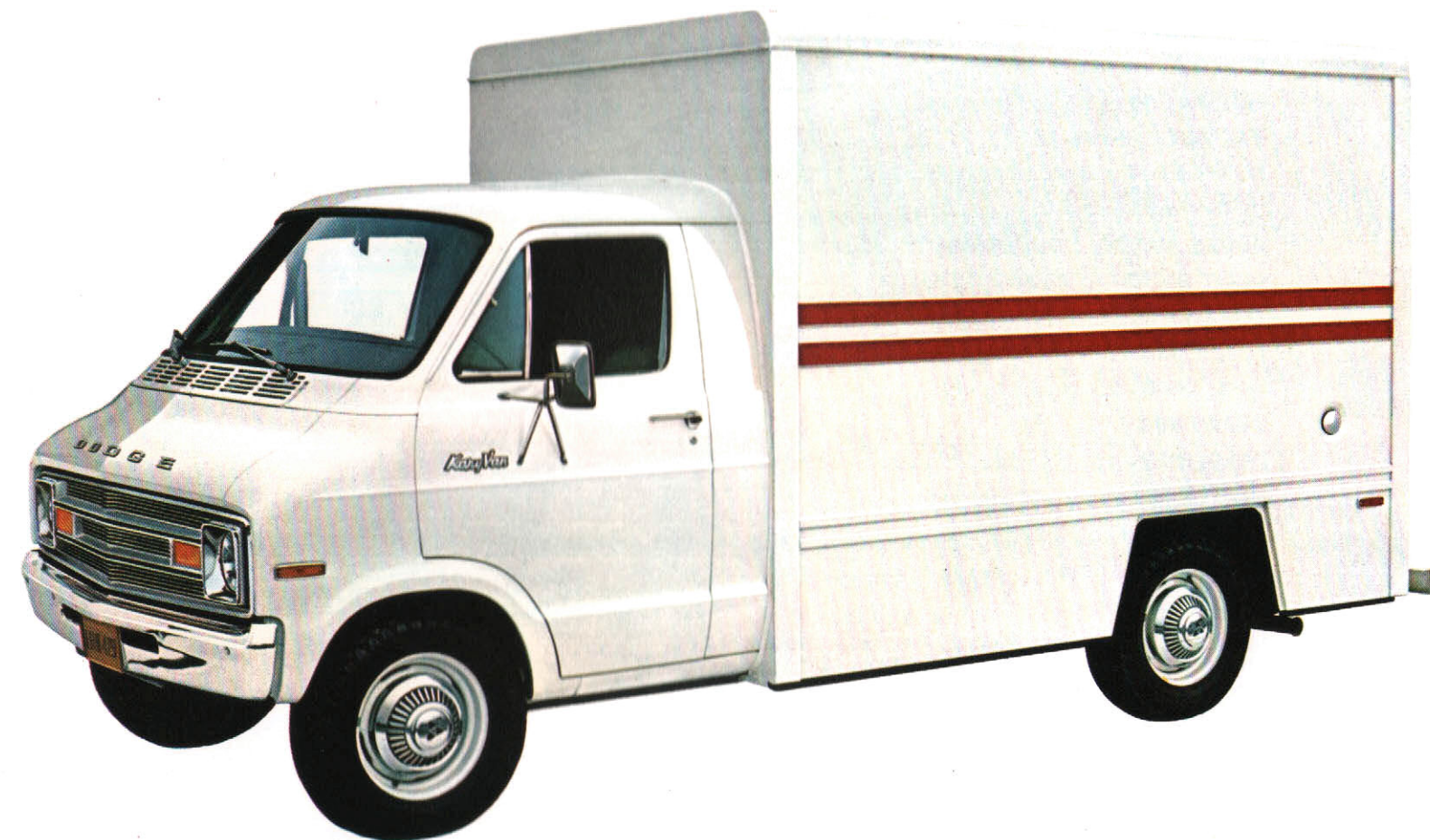

Here is a Dodge Truck model that has gained instant popularity with small businessmen. It offers the roominess of a forward control unit with the agility and maneuverability to get through congested traffic as well as narrow loading areas.

Interior dimensions of the cargo area are: Height, six feet, two inches; width, six feet, four inches; and a flat bed length of 12 feet. (With passenger seat removed, you can load a 15-foot roll of carpeting.) Standard rear door opening is 38 inches. Also available as optional equipment are a 70-inch swing-out door (see illustration at right) and a 70-inch roll-up door.

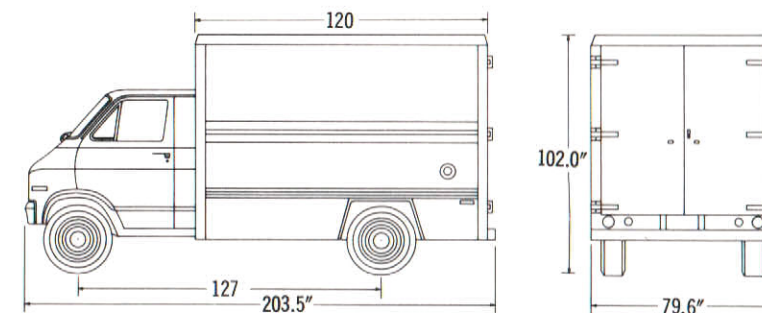

NEW ENAMEL FINISH FOR 1974



TURQUOISE



BRONZE METALLIC



LIGHT GOLD



YELLOW



MEDIUM BLUE METALLIC

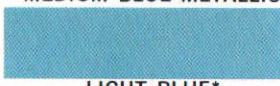

LIGHT BLUE*



WHITE*



BRIGHT RED*



MEDIUM GOLD

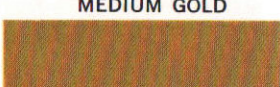

MEDIUM GOLD METALLIC

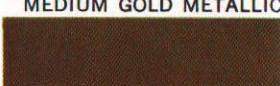

AVOCADO METALLIC

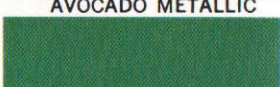

LIGHT GREEN*

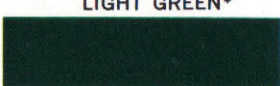

DARK GREEN METALLIC

*Kary Van Colors

N.A.D. (Non-Aqueous Dispersion) Acrylic Enamel is the new finish for Dodge Trademan models. It was selected because of its durability and resistance to fading, nicks, and abrasion.

STANDARD EQUIPMENT

AIR CLEANER—dry-type

ALTERNATOR—41-amp

ANTIFREEZE

ARMRESTS—driver and front passenger

ASHTRAY—driver's compartment

BATTERY—48-amp-hr

BUMPERS—front and rear, painted

DISC BRAKES—front

DOORS, CARGO, DOUBLE—rear, no glass

DOOR LOCKS—all doors

ELECTRONIC IGNITION SYSTEM

FLOOR MAT—driver's compartment side only

FUEL TANK—23 gallons

GLOVE BOX

HEADLINER—driver's compartment

HEATER—Fresh Air with defroster

HORN—single

HUBCAPS—painted

JACK—axle-type

LIGHTS—backup; combined side marker light and reflector; front, amber (2); rear, red (2); dome, driver and cargo compartment

MIRRORS, EXTERIOR—dual, painted, 7½" x 10½" low-mount

OIL FILTER—throw-away-type

OIL PRESSURE INDICATOR LIGHT

SEAT—driver's, bucket-type, including seat belt

SHOCK ABSORBERS—front and rear

SUN VISOR—driver only

SPARE TIRE CARRIER

TRAFFIC HAZARD WARNING SWITCH

WINDSHIELD WASHERS—dual jet

WINDSHIELD WIPERS—two-speed

NOTE: Due to occasional printing irregularities, the colors shown may vary slightly from actual hues. See your Dodge Dealer for accurate color chips.

MINIMUM EQUIPMENT FOR GVW RATING—109" WB						
MODEL	B100 VANS		B200 VANS		B300 VANS	
GVW	4600 LBS.	4800 LBS.	5500 LBS.	6000 LBS.	6200 LBS.	7000 LBS.
REQUIRED EQUIPMENT	STANDARD	1250 LBS. REAR SPRINGS	STANDARD	1400 LBS. FRONT SPRINGS 1750 LBS. REAR SPRINGS H78-15-B (4 PR.) FRONT AND REAR TIRES	STANDARD	8.00-16.5-D (8 PR.) REAR TIRES
GVW					7500 LBS.	7700 LBS.
REQUIRED EQUIPMENT					2300 LBS. REAR SPRINGS 8.00-16.5-E (10 PR.) REAR TIRES	1475 LBS. FRONT SPRINGS 2300 LBS. REAR SPRINGS 8.00-16.5-E (10 PR.) REAR TIRES

MINIMUM EQUIPMENT FOR GVW RATING—127" WB						
MODEL	B100 VANS		B200 VANS		B300 VANS	
GVW	4600 LBS.	4800 LBS.	5500 LBS.	6000 LBS.	6200 LBS.	7000 LBS.
REQUIRED EQUIPMENT	STANDARD	1250 LBS. REAR SPRINGS	STANDARD	1750 LBS. REAR SPRINGS H78-15-B (4 PR.) FRONT AND REAR TIRES	STANDARD	8.00-16.5-D (8 PR.) REAR TIRES
GVW					7700 LBS.	8200 LBS.
REQUIRED EQUIPMENT					1475 LBS. FRONT SPRINGS 2300 LBS. REAR SPRINGS 8.00-16.5-E (10 PR.) REAR TIRES	HEAVY-DUTY PACKAGE

MINIMUM EQUIPMENT FOR GVW RATING—MAXIVAN				
MODEL	B200 VANS		B300 VANS	
GVW	5500 LBS.		6000 LBS.	6200 LBS.
REQUIRED EQUIPMENT	STANDARD	H78-15-B (4 PR.) FRONT AND REAR SPRINGS	STANDARD	8.00-16.5-E (10 PR.) REAR TIRES 2300 LBS. REAR SPRINGS
GVW			7700 LBS.	8200 LBS.
REQUIRED EQUIPMENT			1475 LBS. FRONT SPRINGS 2300 LBS. REAR SPRINGS 8.75-16.5-E (10 PR.) TIRES—FRONT & REAR	HEAVY-DUTY PACKAGE

DIMENSIONS				
EXTERIOR		INTERIOR		
LENGTH, OVERALL	109" WB	176.0"	LENGTH (RR. DRS. TO ENG. HSG.)	
	127" WB	194.0"	109" WB	117.3"
	MAXIVAN 127" WB	212.0"	127" WB	135.3"
WIDTH (ALL)		79.8"	MAXIVAN 127" WB	153.3"
HEIGHT, MAX. (ALL)		80.8"	LENGTH AT BELTLINE (RR. DRS. TO SEATS)	
CARGO DOOR OPENINGS		47.2"	109" WB	95.2"
HEIGHT (ALL)		49.2"	127" WB	113.2"
WIDTH (ALL)			MAXIVAN 127" WB	131.2"
			WIDTH AT WHEEL HSG. (ALL)	50.0"
			WIDTH AT FLOOR (ALL)	68.2"
			HEIGHT, FLOOR TO ROOF (ALL)	53.2"

SPECIFICATIONS

SPECIFICATIONS			
MODEL	B100 VANS	B200 VANS B200 MAXIVANS 127" WB	B300 VANS B300 MAXIVANS 127" WB
AXLE, FRONT—CAPACITY	2700 LBS.	3100 LBS.	3300 LBS.
AXLE, REAR—CAPACITY	2700 LBS.	3300 LBS.	5500 LBS.
—RATIOS FOR 6-CYL. MODELS	3.55(a), 3.2, 3.9(a)	3.55(a), 3.2, 3.9(a)	3.73, 3.54
—RATIOS FOR 8-CYL. MODELS	3.2, 2.9, 3.55	3.2, 2.9, 3.55	3.73, 3.54
BRAKES—SERVICE W/DUAL MASTER CYLINDER AND WARNING LIGHT	YES	YES	YES
—FRONT DISC	11.75" x 1.25"	11.75" x 1.25"	12.82" x 1.19"
—REAR DRUM	10" x 2.5"	11" x 2.5"	12" x 2.5"
BRAKES, POWER	VACUUM 9" OUTSIDE DIAMETER DUAL DIAPHRAGM BOOSTER	VACUUM 9" OUTSIDE DIAMETER DUAL DIAPHRAGM BOOSTER	VACUUM 9" OUTSIDE DIAMETER DUAL DIAPHRAGM BOOSTER
CLUTCH—FOR 6-CYL. MODELS	10" DIA., 11" DIA.	10" DIA., 11" DIA.	10" DIA., 11" DIA.
—FOR 8-CYL. MODELS	11" DIA.	11" DIA.	11" DIA.
ENGINE—6-CYL. MODELS(b)	225 CU. IN.	225 CU. IN.	225 CU. IN.
—8-CYL. MODELS(b)	318 CU. IN., 360 CU. IN.(d)	318 CU. IN., 360 CU. IN.(d)	318 CU. IN., 360 CU. IN.
SPRINGS, FRONT—COIL	1100/1240 LBS. (109" WB) 1200/1340 LBS. (109" WB)	1200/1340 LBS. (109" WB) 1400/1540 LBS. (109" WB)	1400/1570 LBS. (109" WB) 1475/1645 LBS. (109" WB)
—FOR 6-CYL. MODELS—CAP. @ PAD/GROUND	1200/1340 LBS. (127" WB) 1400/1540 LBS. (127" WB)	1400/1540 LBS. (127" WB) 1475/1615 LBS. (127" WB)	1400/1570 LBS. (127" WB) 1475/1645 LBS. (127" WB) 1550/1720 LBS. (127" WB)
—FOR 8-CYL. MODELS—CAP. @ PAD/GROUND	1200/1340 LBS. (ALL WB) 1400/1540 LBS.(c) (ALL WB)	1200/1340 LBS. (109" WB) 1400/1540 LBS.(c) (109" WB) 1475/1615 LBS. (109" WB) 1400/1540 LBS. (127" WB) 1475/1615 LBS.(c) (127" WB)	1400/1570 LBS. (ALL WB) 1475/1645 LBS. (ALL WB) 1550/1720 LBS. (127" WB)
SPRINGS, REAR—LEAF—CAP. @ PAD/GROUND	1000/1170 LBS. 1250/1420 LBS.	1375/1555 LBS. 1750/1930 LBS.	1750/2020 LBS. 2300/2570 LBS.
TRANSMISSION—FOR 6-CYL. MODELS	A250—3-SPD. MANUAL A727—AUTOMATIC	A250—3-SPD. MANUAL A727—AUTOMATIC	A250—3-SPD. MANUAL A727—AUTOMATIC
—FOR 8-CYL. MODELS	A230—3-SPD. MANUAL A727—AUTOMATIC	A230—3-SPD. MANUAL A727—AUTOMATIC	A230—3-SPD. MANUAL A727—AUTOMATIC
TIRES (5) TUBELESS B/W PASS.-CAR-TYPE	E78-15-B (4 PR.) HR78-15-B (4 PR.)(e)	—	—
(4) TUBELESS B/W PASS.-CAR-TYPE	—	G78-15-B (4 PR.) HR78-15-B (4 PR.)(e)	—
(4) TUBELESS B/W TRUCK-TYPE VAN (109"-127")	—	—	8.00-16.5-C (6 PR.) 8.75-16.5-E (10 PR.)
MAXIVAN (127")	—	—	8.00-16.5-D (8 PR.) 8.75-16.5-E (10 PR.)
WHEELS (5) FIVE-HOLE DISC	15" x 5.50"	15" x 6.00"	—
(4) FIVE-HOLE DISC	—	—	16.5" x 6.0"
(4) EIGHT-HOLE DISC	—	—	16.5" x 6.75"

(a) Required with optional Emission Reduction Control System.

(b) Includes Electronic Ignition System, Evaporative and Exhaust Emission Control System (B100 and B200 models), and Heavy-Duty Emission Control System (B300 models).

(c) Minimum front springs required with optional air conditioning.

(d) With automatic transmission only in California.

(e) WSW steel-belted radials.

NOTE: Optional Emission Reduction Control System is required with 6- and 8-cyl. B100, B200 models; and with 318 and 360 8-cyl. B300 models registered in the state of California.

Equipment in red—optional at extra cost.

EXTRA CARE IN ENGINEERING MAKES A DIFFERENCE IN DODGE.



1974 DODGE TRADESMAN VAN. This Dodge van is popular with small businessmen because of its versatility and dependability. Shown above is the B100 model on a 127-inch wheelbase. See the complete lineup of models and wheelbases inside this Dodge Tradesman catalog.



CHRYSLER
MOTORS CORPORATION



Mopar

KEEP YOUR
VEHICLE
"FACTORY NEW"
WITH GENUINE
MOPAR PARTS.



Dodge

Dodge Trucks