

THE WAGON STATION

First stop for 1977: Your Chrysler-Plymouth Dealer.



Plymouth Volaré Wagon

The popularity of Volaré and Volaré Premier Wagons has taken off since their introduction! Six-passenger size, with four doors—and all of them wide enough for easy in-and-out. Inside, you have space in all directions, with a great view through Volaré's broad glass areas. This year you can choose a new optional 60/40 cloth split-bench seat with vinyl accents, folding center armrest and dual reclining seat-backs.

And behind you, 72.8 cu. ft. of cargo space. That's 70% as much usable cargo space as you'll find in our full-size wagons!

And Volaré gives you all this room

in a wagon that's small, inexpensive to own, and makes attractive mileage figures. EPA estimates show that Volaré Wagon, with 225 2-bbl. Super Six* and manual transmission, got 17 mpg in the city, 24 mpg highway.** Standard engines for Volaré Wagon are the Super Six or the 318 V-8. Also standard is Isolated Transverse Suspension System that helps produce Volaré's big-car ride.

1977 Volaré and Volaré Premier Wagons. The small wagons that put the accent on comfort.

*Not available in Calif. or at altitudes over 4000 ft.
 **Your actual mileage may differ, depending on how and where you drive, the condition of your car and its optional equipment.



Volaré Wagon.



Optional 60/40 cloth split-bench seat with vinyl accents, folding center armrest, and dual reclining seat-backs.



Family-sized 72.8 cu. ft. cargo area that gives you lots of room to work with or play with.



Standard Volaré all-vinyl bench seat and soft door trim.



Recessed spare tire well is standard. Lockable side storage compartments are standard on Premier wagons.

1977 Volaré Wagon Dimensions

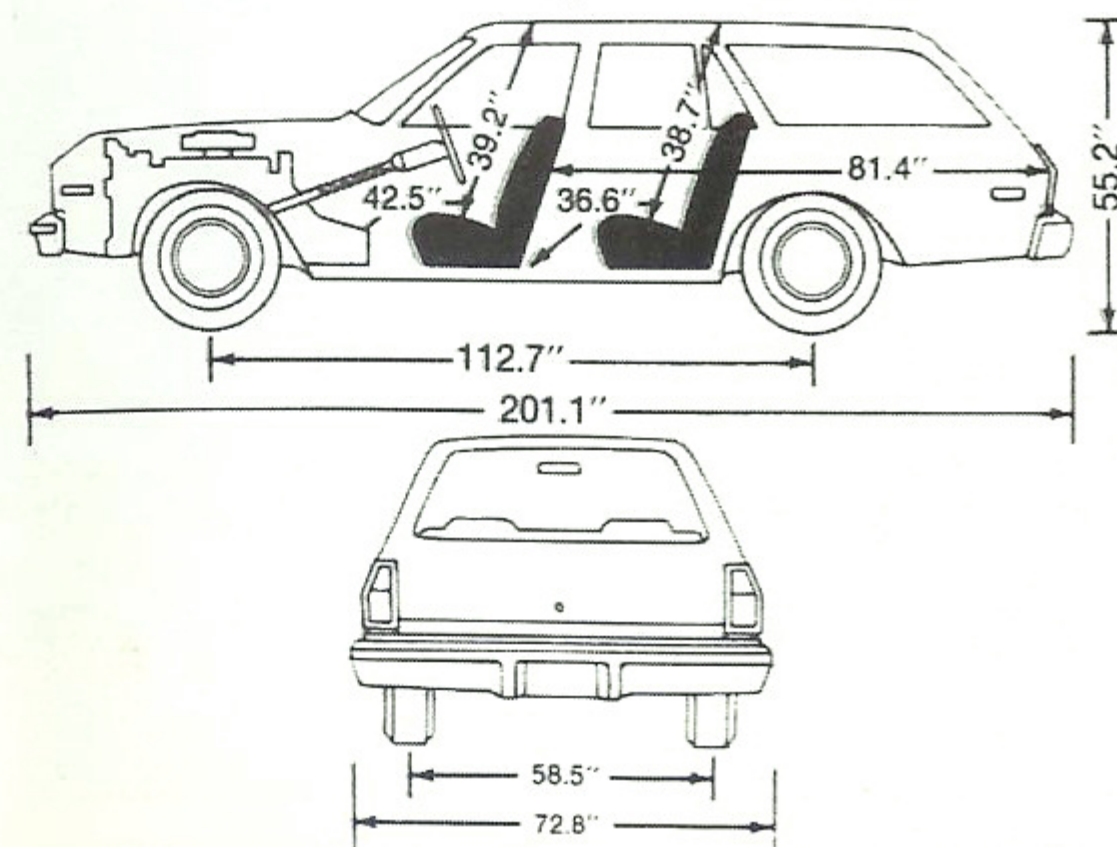



Volare Premier Wagon

Some items pictured on vehicles on this and other pages of this catalog are extra cost options.

Plymouth Voyager

Hello, world!

Here comes Plymouth Voyager...the wagon that takes you down new roads to driving comfort, convenience and just plain fun!

This handsome, multi-purpose vehicle comes in Voyager, Voyager Custom and Voyager Sport trim levels—plus the Premier Trim package. With optional features such as high-back Command Seats, without or with the smooth new turn-around swivel feature, including dual armrests on passenger seat and an inboard armrest on the driver's seat...color-keyed carpeting...Sunscreen glass in side (except front-door glass) and rear windows for interior privacy and reduced heat load.

Voyager has good-looking, easy-going features such as durable, color-keyed vinyl seats, armrests, and padded sun visors.

You have a choice of two wheelbases—109" and 127"—plus the

extra-spacious extended body with seating potential for up to 15. And a range of 910 lbs. to a hefty 3485 lbs. of payload in the largest capacity.

This year, even more convenience. Rear 3-passenger seats have a quick-disconnect feature so you can take them away or leave them when you need more cargo space.

The driving and handling is easy on you...with standard power front disc brakes, independent front suspension and short turning radius. Its high ground clearance, heavy-duty and trailer-assist equipment options offer you more good ways to go.

Rapid-cool-down air conditioning...AM/FM radio and dealer-installed CB radio, auxiliary heater, automatic speed control—it's a far-ranging choice.

1977 Plymouth Voyager. There's a world of ways to enjoy owning one. (For complete information on this vehicle, see the separate Plymouth Voyager Catalog.)



Voyager Sport optional interior with high-back Command Seats in cloth-and-vinyl.



Large engine hood makes service access simple and easy for maintenance and repair work.



Standard single rear door for easy one-handed opening.

1977 Voyager Dimensions

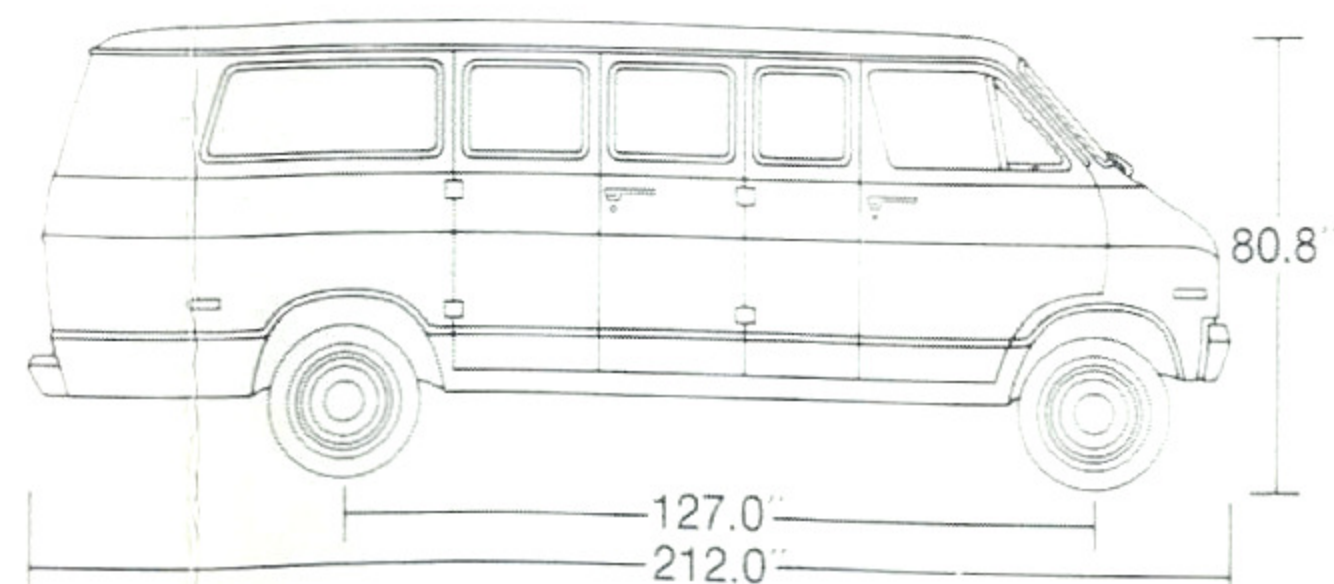
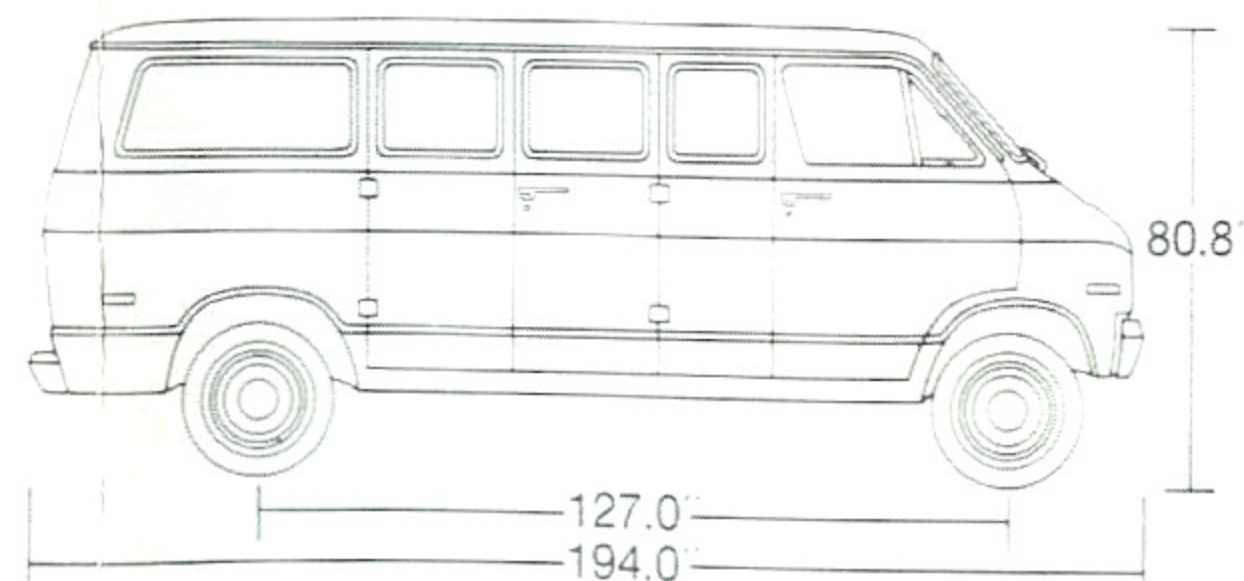
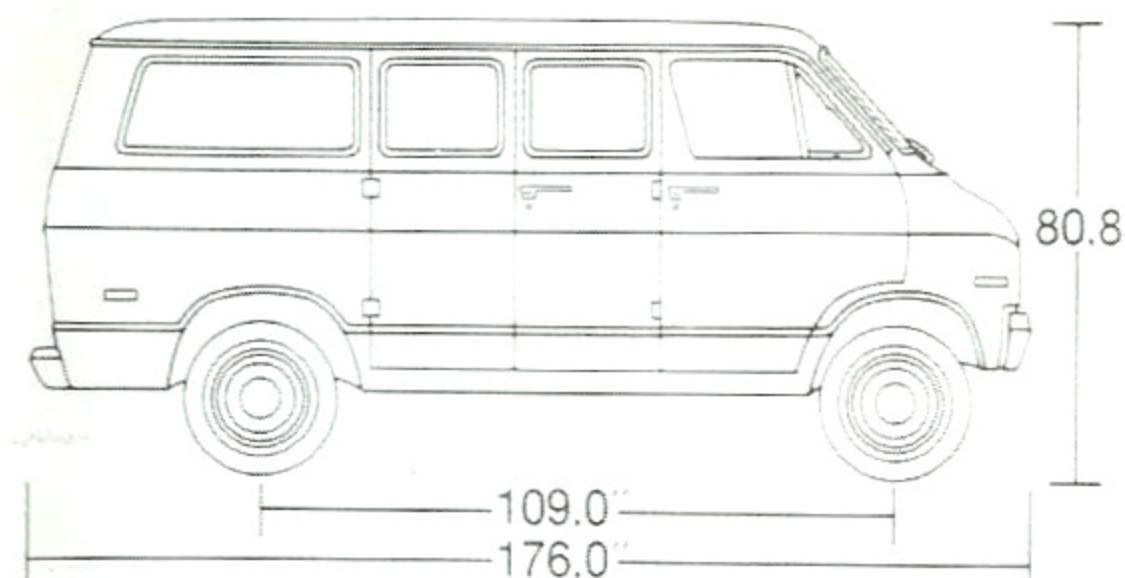



Plymouth Voyager

Plymouth Fury Wagon

These handsome Fury wagons are outstanding for their "just right" combination of mid-sized handling and carrying capacity. This year there's even more to like about Fury's looks...new stacked square headlights, new crisp grille texture with a wide molding. Fury comes with a young, family-sized price. In Fury Sport Suburban, you'll be impressed with its capacity for making people comfortable. With foam-padded seat-backs and cushions, elegant door trim, padded instrument panel and full carpeting in passenger and cargo area. And rich woodgrain exterior accents come with the Sport Suburban.

And beyond what meets the eye, there's a standard heavy-duty suspension...3-way doorgate...power steering...power front disc brakes...automatic transmission...and a free-breathing, smooth-running 360 V-8 up front.

Getting down to basics, it's a good-looking wagon with a lot of value appeal. And options like rapid-cool-down air conditioning, adjustable roof rack, air deflector, power doorgate window, automatic speed control, radio and tape systems and dealer-installed CB radio. 1977 Fury and Fury Sport Suburban wagons . . . the popular choices in the mid-size range.

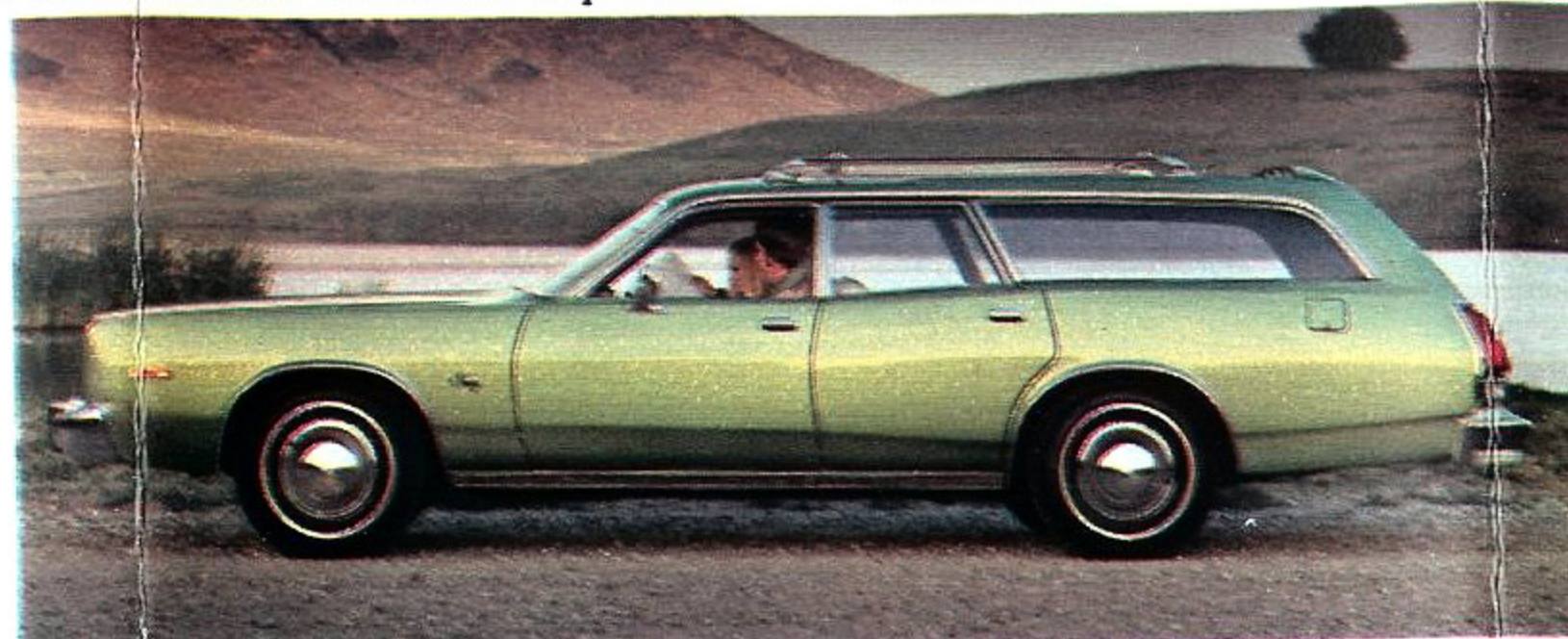

Plymouth Fury Suburban.



Optional all-vinyl 60/40 bench seat with folding center armrest and dual recliners.

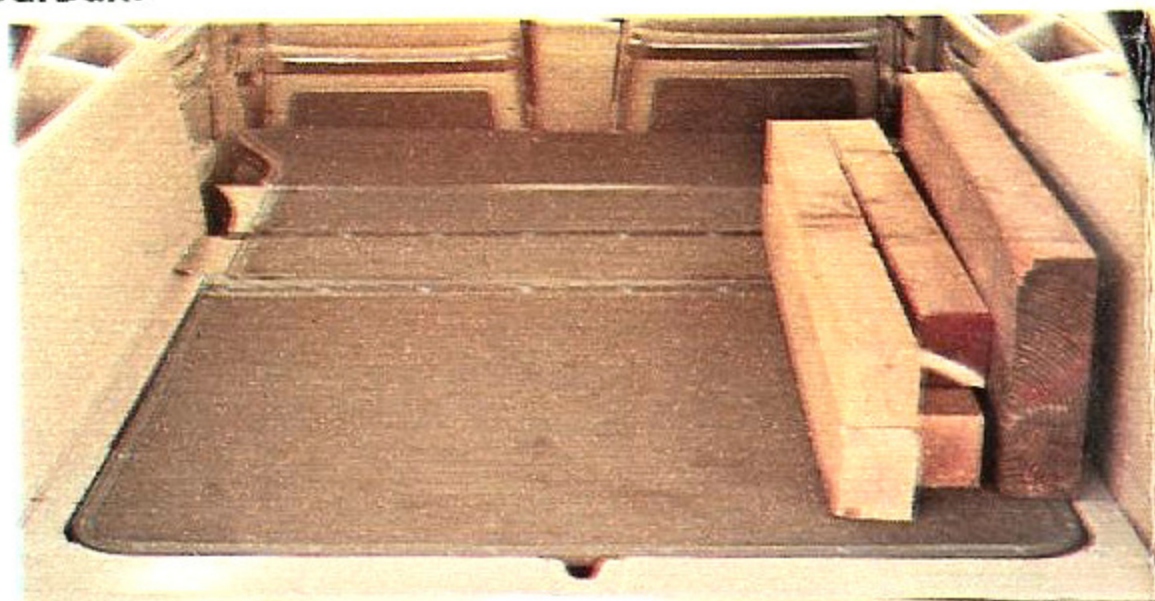

Rear deck has 84.7 cu. ft. cargo volume.

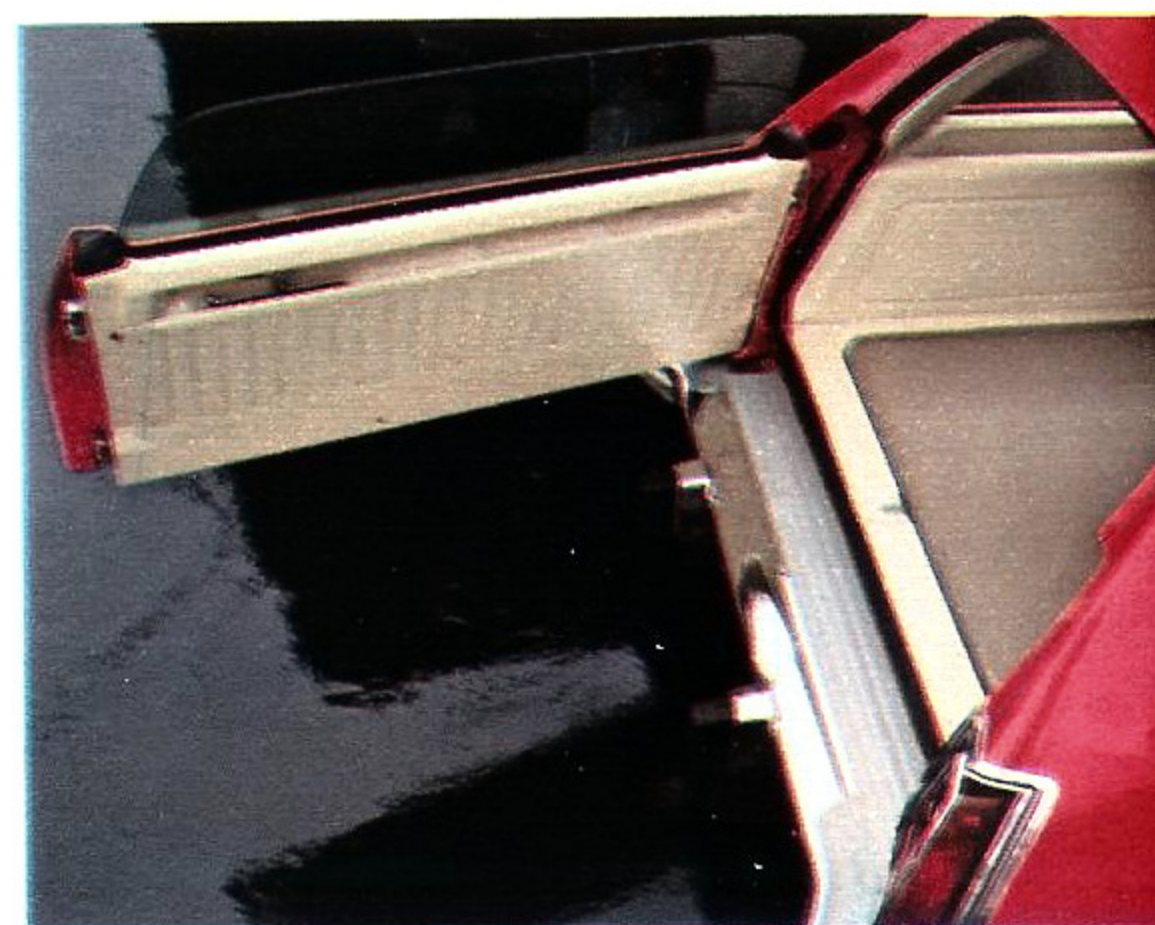

Convenient three-way doorgate is standard.

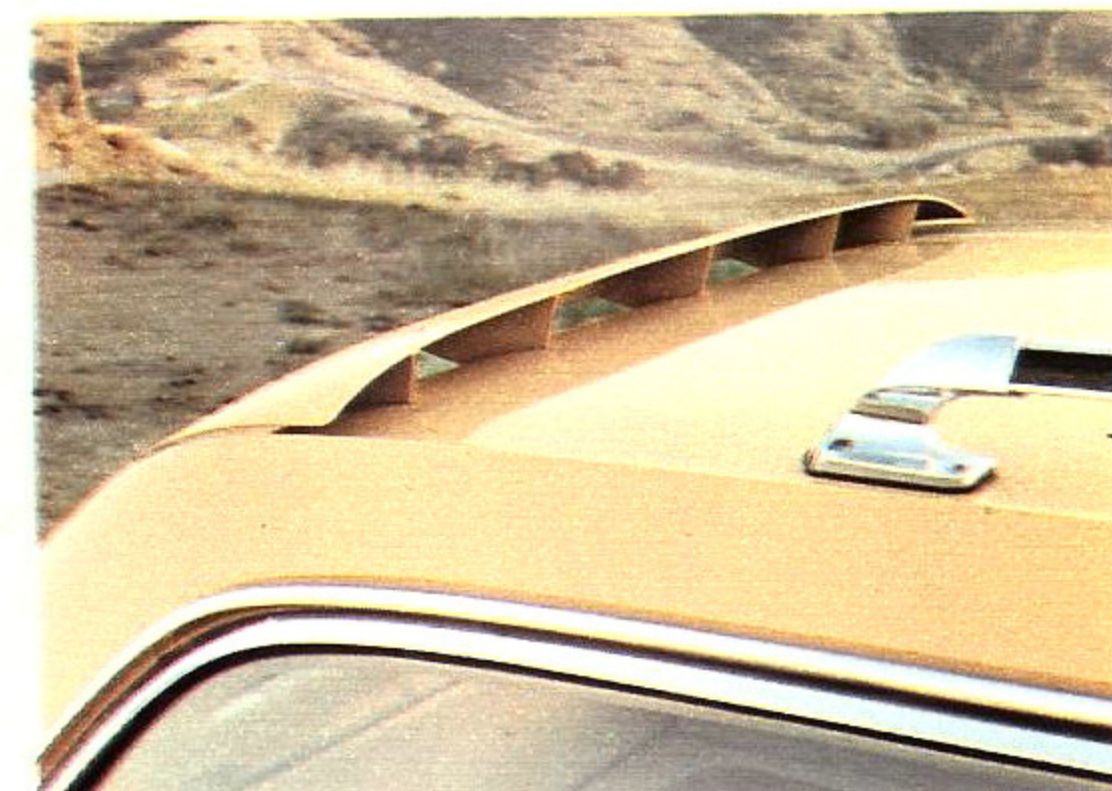

Optional roof air deflector.

1977 Fury Suburban Dimensions

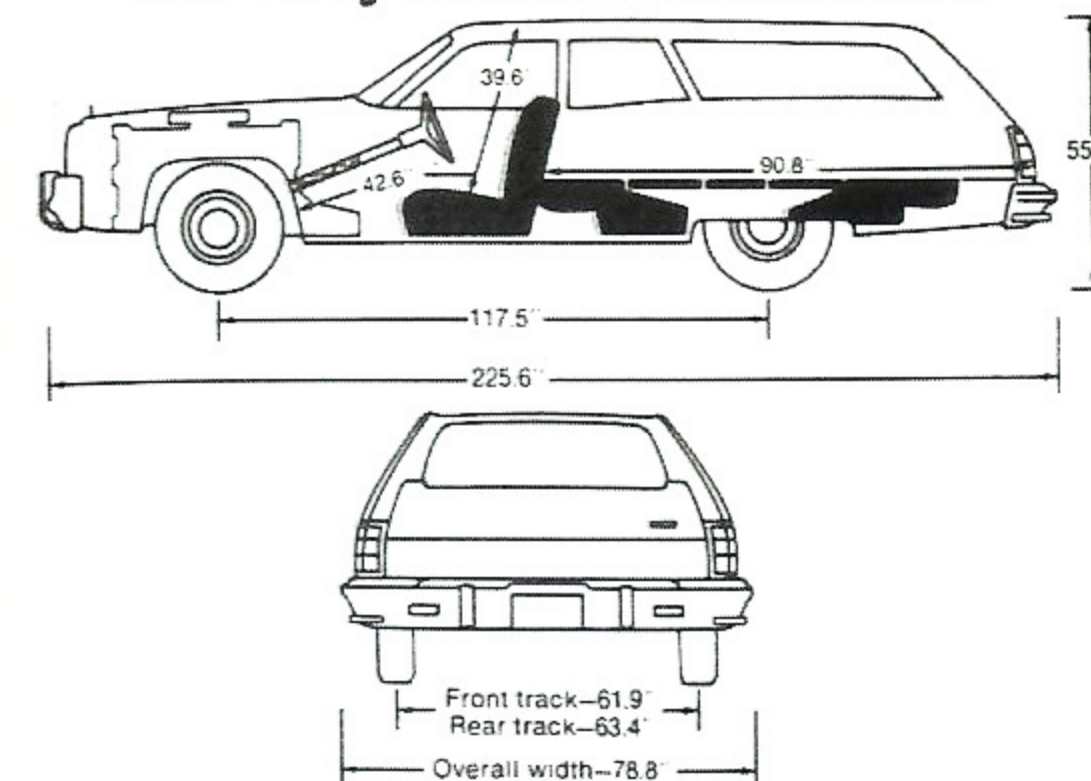



Plymouth Fury Sport Suburban

Plymouth Gran Fury Wagon*

These are the wagons that handle people or cargo with superb ease, big-car comfort and style!

In Gran Fury Sport Suburban, you have 102.4 cu. ft. of cargo area. That's room for a week-full of kids, Cub Scout troops—even 4' x 8' paneling.

Standard pleasures of driving this big, beautiful wagon extend to foam-padded vinyl split-bench seat with center armrest...a fold-down third seat (3-seat model)...color-keyed carpeting...cargo light...3-way doorgate with power window for loading ease.

Other Gran Fury Sport Suburban road-handling standards are power

front disc brakes, power steering, TorqueFlite automatic transmission, and steel-belted radial-ply tires to help make the most of your fuel mileage. For a more basic version of this top-flight quality and features, look to Gran Fury Suburban.

Optional equipment and accessories take you from power door locks, power seats, electronic digital clock and stereo radio and tape systems... through a neatly concealed lockable storage bin, electric rear window defroster, with many fine choices in between. So no matter where you're going, Gran Fury Suburban and Sport Suburban are the wagons that bring elegance with you.



Plymouth Gran Fury Suburban wagon.



Optional Gran Fury Sport Suburban 50/50 all-vinyl split-bench seat with folding center armrests and passenger-side reclining feature.



Large cargo area with 102.4 cu. ft. capacity.



Optional Gran Fury Sport Suburban cloth split-bench seats with vinyl accents, folding center armrest.



Optional luggage rack.

1977 Gran Fury Wagon Dimensions

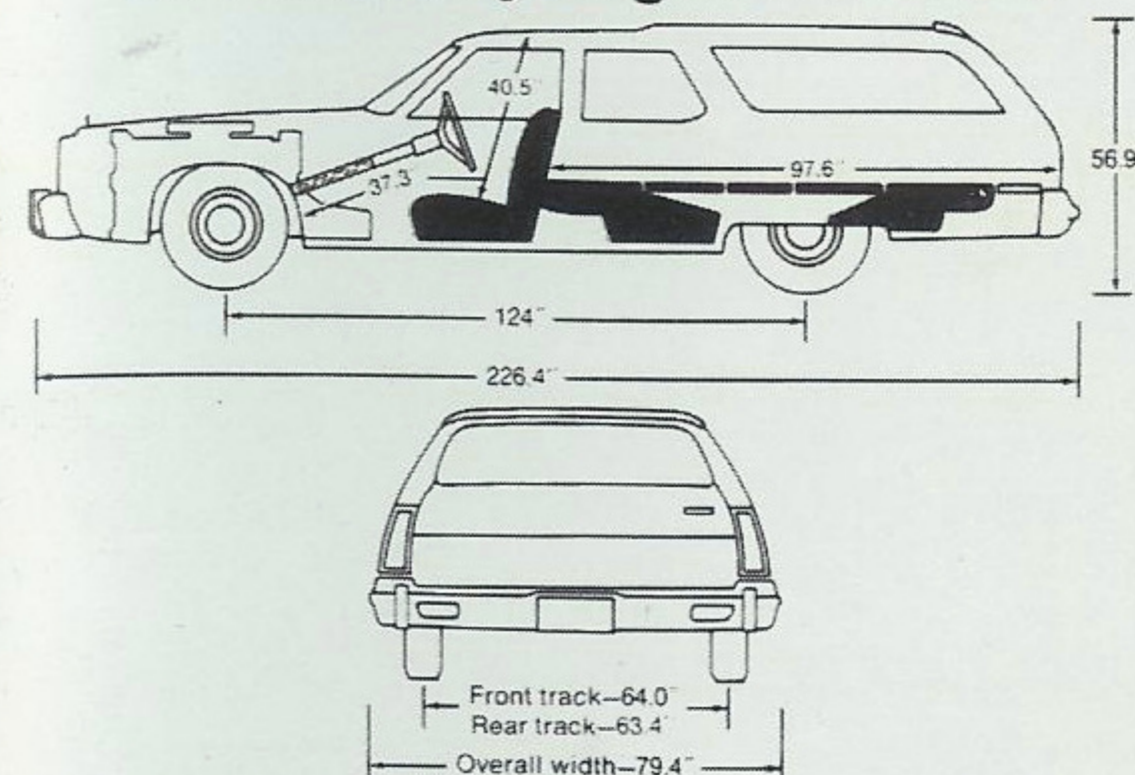

*Not available in Calif. or at altitudes over 4000 ft.



Plymouth Gran Fury Sport Suburban.

Chrysler Town & Country*

The wagon of wagons! It could only be Chrysler Town & Country, in two- or three-seat versions.

So exceptionally spacious...so magnificently equipped...so superbly tailored for an active yet elegant lifestyle.

The Town & Country interior brings you in luxurious touch with deep-foam, all-vinyl 50/50 bench seats with individual comfort controls. Rich carpeting extends from front floor all the way to the rear doorgate.

In between there's 102.4 cubic feet of cargo space. That's room for a 4'x8' sheet of paneling—without moving the front seats forward!

Standard Town & Country features give you the convenience of a 3-way doorgate with power window, automatic doorgate locking

when ignition is turned on, and a roof air deflector. Courtesy and convenience lighting where you want it.

For rough going, it's good to know you have a suspension system tuned to steel-belted radial-ply tires, including front sway bar. And this year, the high-performing standard 440 V-8 has the incredible Electronic Lean Burn System...to fire with precision, to accelerate smoothly.

All in one beautiful wagon—the utility you want, the luxury you love.

1977 Town & Country. The elegant standard by which all other wagons can be judged.

*Not available in California or at altitudes over 4000 feet.



Standard vinyl 50/50 bench seat, with folding center armrests, and reclining passenger-side seat.



Three-way doorgate is standard. When dropped down, doorgate is almost level with cargo floor for easy access and loading.



With rear-facing third seat, you have 8-passenger capacity.

1977 Town & Country Dimensions

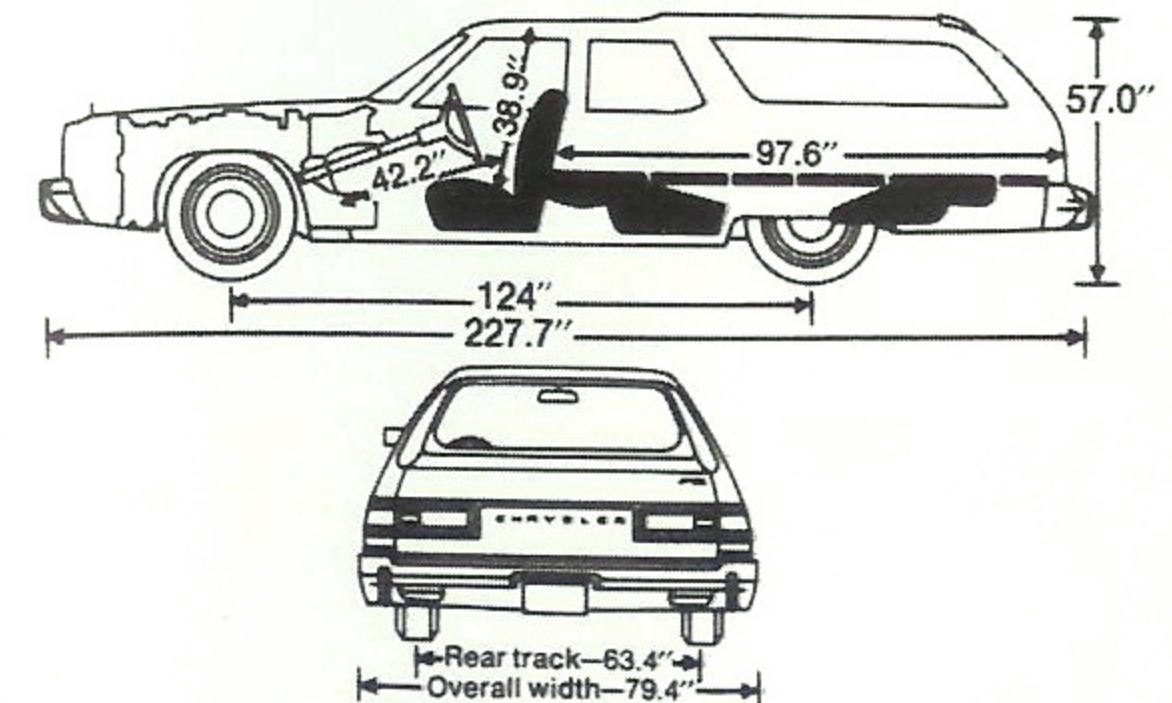



Chrysler Town & Country station wagon.

Optional Equipment and Accessories for Added Comfort, Convenience.



Plymouth Gran Fury Sport Suburban equipped for smooth, reliable trailer-towing with heavy-duty package A35. See separate Chrysler-Plymouth Trailer-Towing Catalog for details.



Electronic Digital Clock is accurate to within one minute per month. (Town & Country and Gran Fury only.)



Automatic Lock on doorgate locks when ignition is turned on.



AM/FM Stereo Radio with 8-Track Stereo Tape (equipped with 4 speakers).

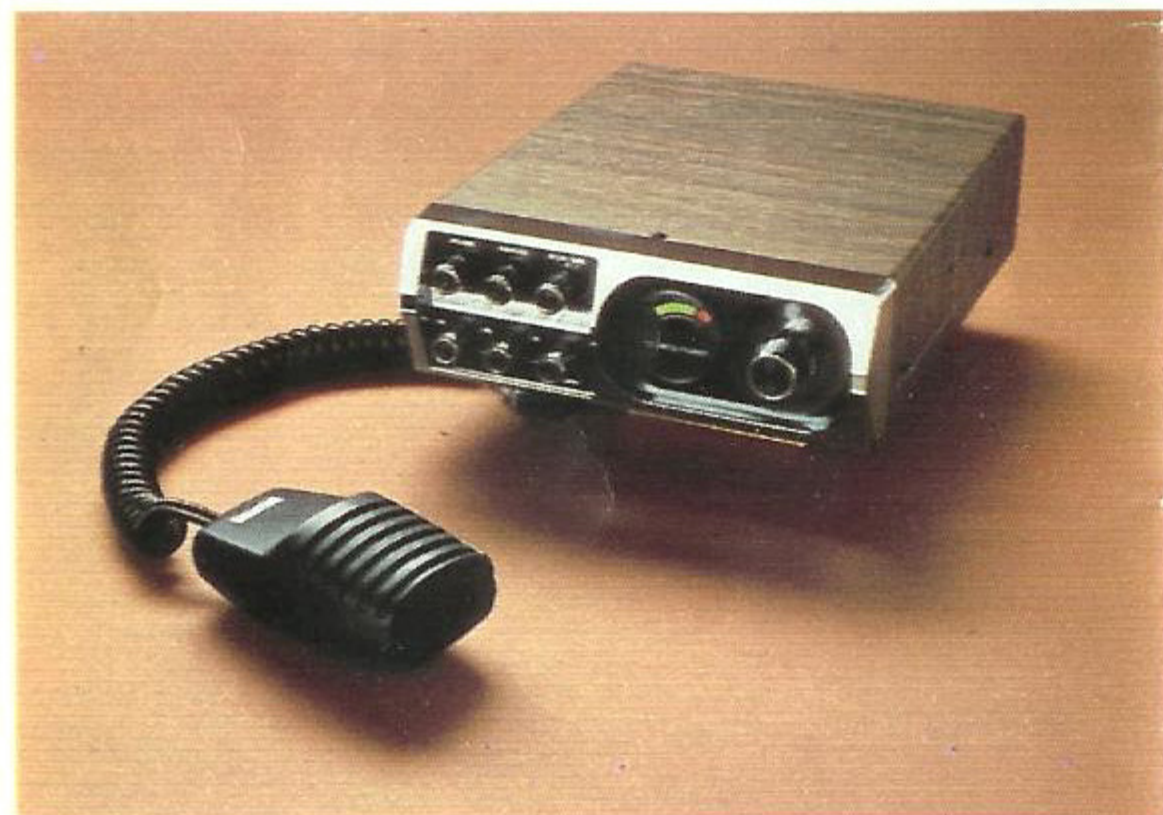

CB Radio is a dealer installed option that has all America talking!



Tilt & Tel Steering Wheel, shown here in three positions. (Gran Fury / Town & Country only.)

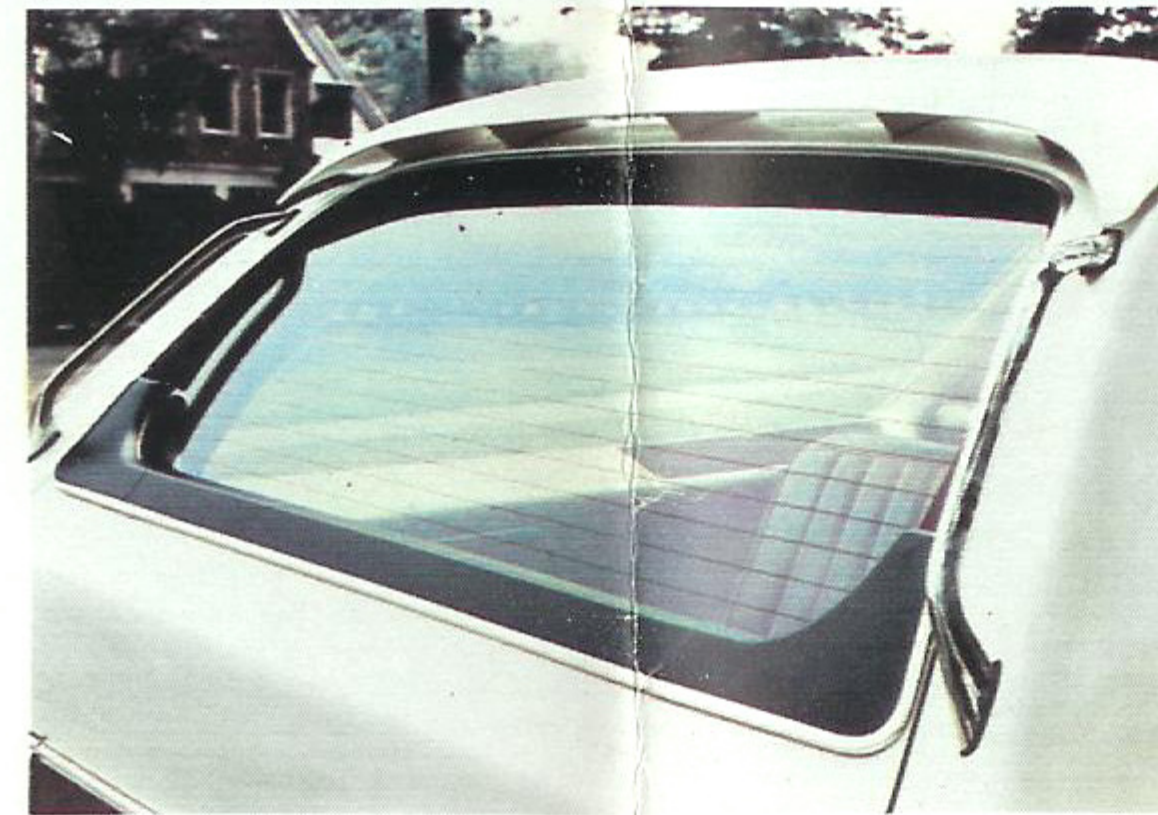

Electrically heated rear window defroster. When this option is ordered, 100-amp alternator is standard. (65-amp on Volaré.)



Long-Life Battery, a 500-amp powerhouse that is the most dependable battery you can buy.

POWER

Power steering, power brakes, power windows, power door locks, power seats, power doorgate.

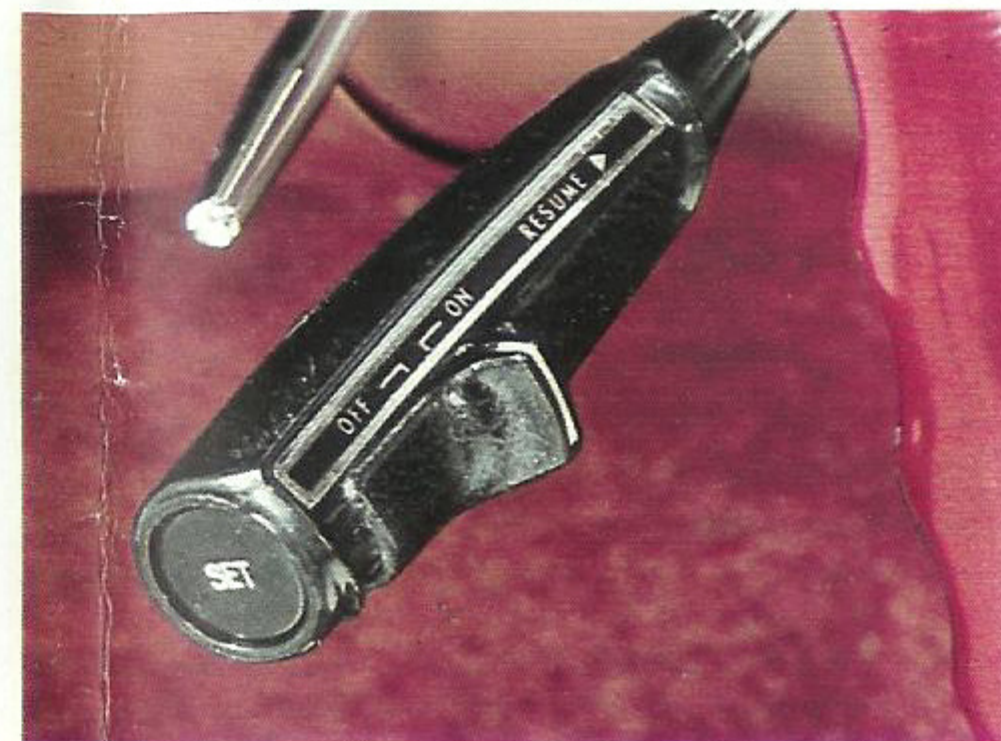

Automatic Speed Control lets you select and hold a steady speed for driver ease and comfort. Can improve mileage in highway driving.

Chrysler leads the way in electronics for automobiles among all U.S. auto manufacturers.

The computer-controlled Electronic Lean Burn System is now standard on Chrysler 400* and 440 V-8's...the engines that think!

A totally new approach to engine control, the Electronic Lean Burn System employs a small computer, making it possible to use exceptionally lean mixtures during part-throttle operation...an average 18-to-1 air/fuel ratio. The precise moment for spark plug firing is determined instantaneously by the Spark Control Computer. It continuously monitors engine speed, and adjusts for driving conditions and air temperatures. The result is improved engine performance and smooth acceleration. Chrysler continues to move ahead with electronic systems that improve the precision and performance of your car's engine.

*Not available in California or at altitudes over 4000 feet.

Station Wagon Options

	Volaré	Volaré Premier	Fury Suburban	Fury Sport Suburban	Gran Fury Suburban ¹	Gran Fury Sport Suburban ¹	Chrysler Town & Country ¹	Check List
Air conditioning	O	O	O	O	O	O	O	
Air conditioning with auto-temp control	N/A	N/A	N/A	N/A	O	O	O	
Air deflector	O	O	O	O	O	S	S	
Automatic height control	N/A	N/A	N/A	N/A	O	O	O	
Automatic speed control	O	O	O	O	O	O	O	
Automatic doorgate lock	N/A	N/A	O	O	O	O	S	
Axle Sure-Grip Differential	O	O	O	O	O	O	O	
Battery, 500 amp. Long Life ⁴	O	O	O	O	O	O	S	
Bumper step pads (rear)	N/A	N/A	N/A	N/A	O	O	O	
Carpet, cargo compartment	O	S	S	S	O	O	S	
Clock, electric	O	O	O	O	O	O	S	
Clock, electronic digital	N/A	N/A	N/A	N/A	O	O	O	
Defroster rear window, electric	O	O	O	O	O	O	O	
Door edge protectors	O	O	O	O	O	O	O	
Emissions Control System (Cal. or at alt. over 4000')	O	O	O	O	N/A	N/A	N/A	
Engine temp. and oil pressure gauges	S	S	S ²	S ²	O	O	S	
Engines—225-2, 6-Cyl. ¹	S	S	N/A	N/A	N/A	N/A	N/A	
318 V-8 2-bbl.	S	S	N/A	N/A	N/A	N/A	N/A	
360 V-8, 2-bbl. ¹	O	O	S	S	N/A	N/A	N/A	
360 V-8, 4-bbl.	N/A	N/A	S ³	S ³	N/A	N/A	N/A	
400 V-8, 4-bbl. ¹ with Electronic Lean Burn	N/A	N/A	O ¹	O ¹	S	S	N/A	
440 V-8, 4-bbl. with Electronic Lean Burn	N/A	N/A	N/A	N/A	O	O	S	
Horns, dual	O	O	O	S	O	O	S	
Inside hood release	O	O	O	O	S	S	S	
Light Package	O	O	O	O	O	O	O	
Luggage rack, adjustable	O	O	O	O	O	O	O	
Mirror, left and right remote control	O	O	O	O	O	O	O	
Molding, upper door frame	O	S	O	S	O	S	S	
Molding, belt	O	S	N/A	N/A	S	S	S	
Pedal dress-up	N/A	N/A	O	O	N/A	N/A	S	
Power door locks	O	O	O	O	O	O	O	
Power doorgate window	N/A	N/A	O	O	S	S	S	
Power seats	O	O	O	O	O	O	O	
Power steering	O	O ⁵	S	S	S	S	S	
Power side door windows	O	O	O	O	O	O	O	
Radio, AM, AM/FM, or AM/FM stereo	O	O	O	O	O	O	O	
Radio, AM/FM stereo with 8-track stereo tape	O	O	O	O	O	O	O	
Rear Speaker	O	O	O	O	O	O	O	
Steering wheel, luxury	O	O	O	O	O	O	O	
Steering wheel, Tuff	O	O	N/A	N/A	N/A	N/A	N/A	
Steering column, Tilt & Telescope	N/A	N/A	N/A	N/A	O	O	O	
Steering column, Tilt	O	O	O	O	N/A	N/A	N/A	
Suspension, Heavy-duty	S	S	S	S	O	O	O	
Tinted glass	O	O	O	O	O	O	O	
Tires, steel-belted radial-ply	O	O	O	O	S	S	S	
Trailer-towing package, light	O	O	O	O	O	O	O	
Trailer-towing package, heavy	N/A	N/A	O	O	O	O	O	
Undercoating and hood pad	O	O	O	O	O	O	O	
Vent windows	N/A	N/A	N/A	N/A	O	O	O	
Wheel covers, deluxe	O	O	O	O	O	O	S	
Wheel covers, Premier/Premium	O	O	O	O	O	O	O	
Wheel covers, wire	O	O	O	O	N/A	N/A	N/A	
Wheels, Rallye Road	O	O	N/A	N/A	N/A	N/A	N/A	
Wheels, Styled Road	O	O	O	O	N/A	N/A	N/A	
Wipers, Deluxe	O	O	O	O	S	S	S	

¹Not available in Calif. or at altitudes over 4000 ft. ²Temp. gauge only. ³Available Calif. or at altitudes over 4000 ft. ⁴Std. with 440 engine. ⁵Std. on V-8. O—Optional S—Standard N/A—Not available

1977 Chrysler-Plymouth Colors

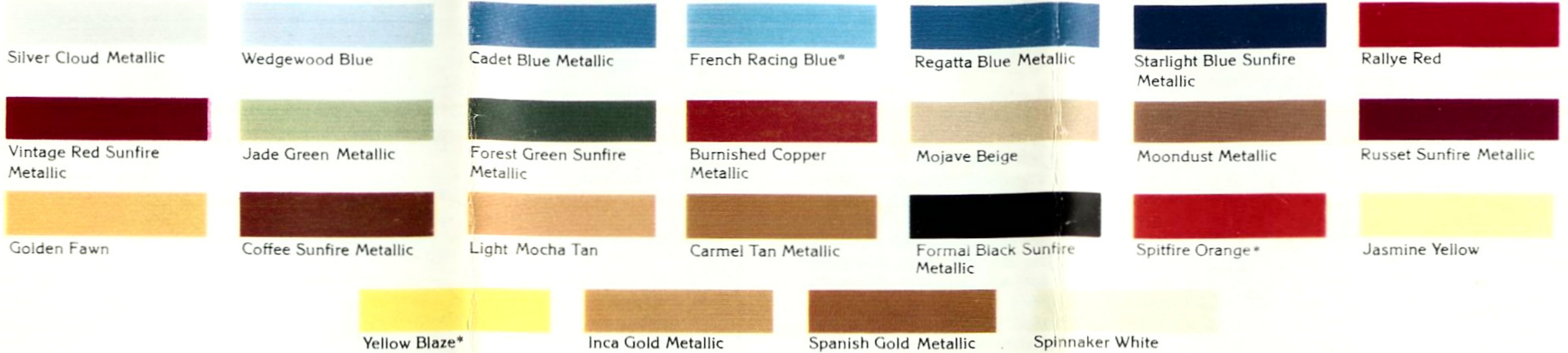

*High Impact Paint Colors—Designed primarily for Coupe usage.

1977 Voyager Colors



NOTE: Due to occasional printing irregularities, the colors shown may vary from actual hues. See your Chrysler-Plymouth Dealer for accurate color chips.

All product illustrations and specifications are based on authorized information. Although descriptions are believed correct at publication approval, accuracy cannot be guaranteed. Some of the equipment shown on product illustrations is optional, at extra cost. Chrysler Corporation reserves the right to make changes from time to time, without notice or obligation, in prices, specifications, colors and materials, and to change or discontinue models.