

1989 Plymouth

ACCLAIM

IF IT'S IMPORTANT TO YOU,
IT'S IMPORTANT TO PLYMOUTH.





Acclaim LX, shown in Bright White Clear Coat.

About this catalog. We have tried to make this catalog as complete as possible. However, since the time of printing, some of the information you'll find here may have been updated. Your dealer has details, and you should ask him for current information before ordering.

Some of the equipment shown or described throughout this catalog is optional or available at extra cost.



Customer satisfaction is built into every 1989 Plymouth. It's part of our corporate philosophy, which represents a solid commitment to teamwork, quality, *and* listening to our customers...and it shows. It shows in our products, our employees, our dealers, and our sales professionals.

Plymouth Acclaim is a perfect example. Consumer research helped us make Acclaim roomy, fun to drive, and a great value that's loaded with sophisticated technology and more than 50 standard features. Customer satisfaction is driving Plymouth. And it shows.

Lee A. Iacocca



1989 Plymouth

ACCLAIM



*Acclaim LX, shown in
Black Cherry Pearl Coat.*

**Plymouth Acclaim. Contemporary styling,
front-wheel drive, spacious seating.
Acclaim gives you more.**



PLYMOUTH ACCLAIM LX.
Luxurious driving pleasure.



Acclaim LX has a "Traveler" mini trip computer and graphic message center that includes light outage indicators.



(top) Acclaim's trunk, with remote release and low liftover height, has 14.4 cubic feet of capacity with seatback up. (above) Convenient map light for nighttime reading.

(left) Acclaim LX interior with optional 50/50 split bench seat (bucket seats and floor console standard), shown in Bordeaux. Includes driver's side manually adjustable lumbar support and adjustable head restraints.

Luxury and style in perfect balance, that's the top-of-the-line Plymouth Acclaim LX.

Standard LX exterior features include 15-inch cast aluminum "lace" wheels, lower bodyside cladding, fog lights, deck lid luggage rack, and aerodynamic styling. Acclaim LX's quiet, expansive interior has standard five-passenger seating, full-length center console (with storage bins, cup and coin holders, and fold-down armrest), or optional seating for six, plus a leather-wrapped luxury steering wheel.

Acclaim LX is powered by an advanced 3.0-liter V-6 multipoint EFI engine* and an all-new Ultradrive electronic fully adaptive four-speed overdrive automatic transaxle.

*See page 22 for further engine information.



Acclaim LX, shown in Black Cherry Pearl Coat.

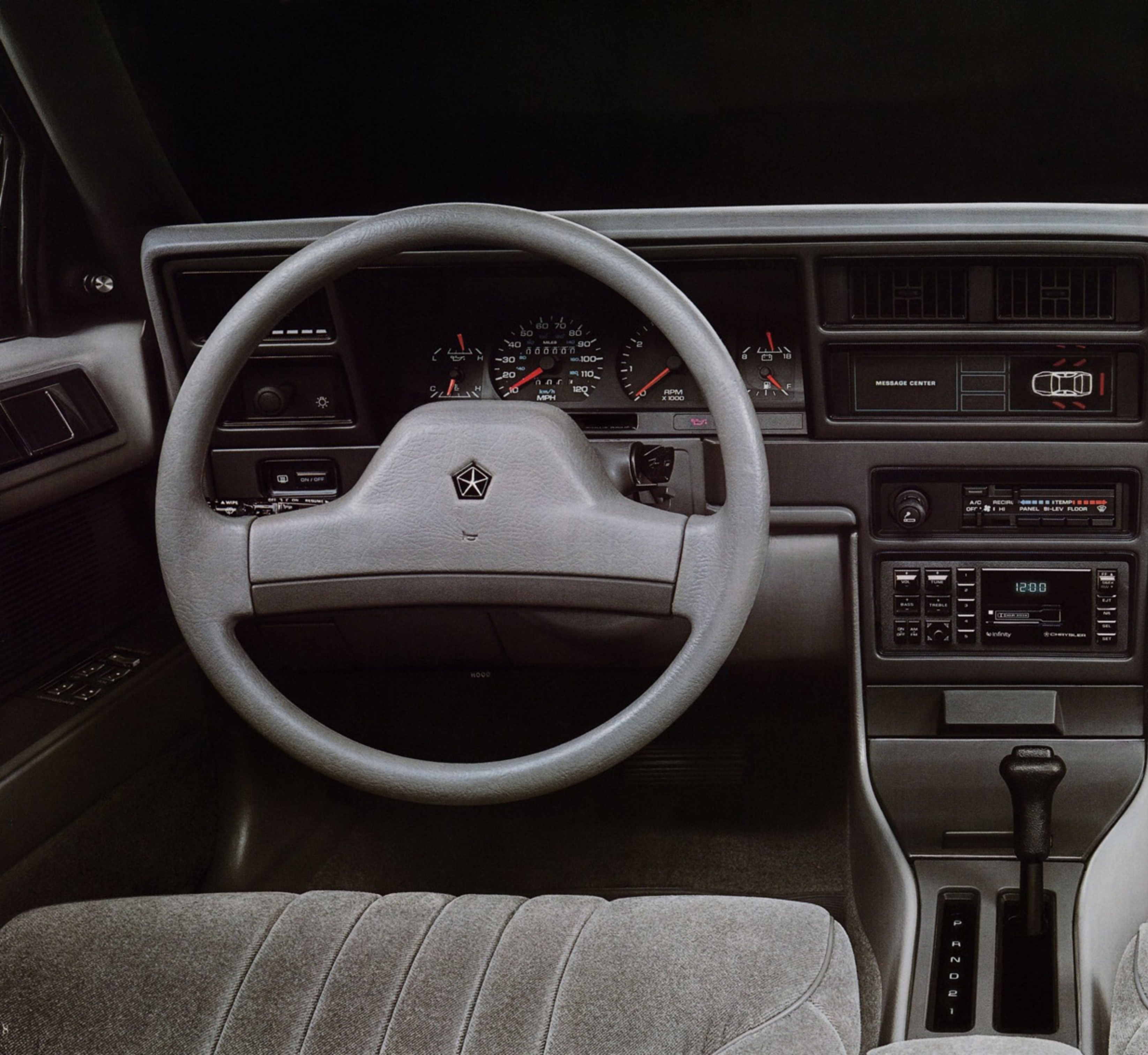

PLYMOUTH ACCLAIM LE.
It puts the fun back in family driving.



Dual illuminated visor vanity mirrors are standard on Acclaim LE and LX.

(left) Acclaim LE instrument panel, shown in Dark Gray Quartz. Includes electric speedometer, tachometer, and trip odometer; gauges for engine oil pressure, fuel level, voltage, and engine coolant temperature; and "Low Fuel," "Check Engine," "Low Oil Pressure," and "Check Gauges" warning lights.



(top) Acclaim LE and LX have 55/45 fold-down split rear seatback for spacious storage, locks for security. (above) Center console, with covered storage bin holds garage door opener, cassette tapes, cups, and coins. Interior shown in Medium Quartz.

Refined Acclaim LE offers luxurious driving and style with advanced engineering technology. Appealing interior fabrics, generous seating and leg room, plus expert fit and finish mean satisfaction for drivers and passengers.

Acclaim LE standard features include 14-inch "lace" wheel covers, accent stripes, lower bodyside cladding and upper bodyside protective molding, dual remote outside mirrors, tinted glass, rear window defroster, electronic speed control, tilt steering, AM stereo*/FM stereo radio with four coaxial speakers, and graphic message center (with warning lights for exterior light outages).

*Some AM stereo broadcasting may not be compatible with this radio.



Acclaim LE, shown in Dark Gray Quartz Clear Coat. Advanced Clear Coat paint gives every Acclaim a durable, high-gloss finish.



PLYMOUTH ACCLAIM LE.
The exterior promises greatness.
Acclaim's interior confirms it.



Acclaim LE standard bucket seats, with driver's side adjustable lumbar support and adjustable head restraints, shown in Medium Quartz.



Midsized Acclaim has seating for six with optional 50/50 split bench seat without floor console. Interior shown in Medium Quartz. Generous front and rear leg room, rear seat shoulder belts for outboard passengers, and child-guard rear door locks are standard.



Acclaim LE, shown in Black Clear Coat.

Plymouth carefully researched and listened to American drivers and passengers to create Acclaim LE, with features that bring you driving satisfaction. Comfortable cloth and vinyl upholstery is standard, along with generous front and rear leg room, side window demisters, flow-through ventilation, tilt steering, and electronic speed control. Premium cloth reclining bucket seats with driver's side lumbar support adjuster (an optional 50/50 split bench front seat offers seating for six), adjustable front head restraints, dual illuminated sun visor vanity mirrors, and full front console with folding center armrest are also standard.



Plymouth Acclaim, shown in Medium Taupe Clear Coat.



PLYMOUTH ACCLAIM.
The new standard in affordable midsize family sedans.

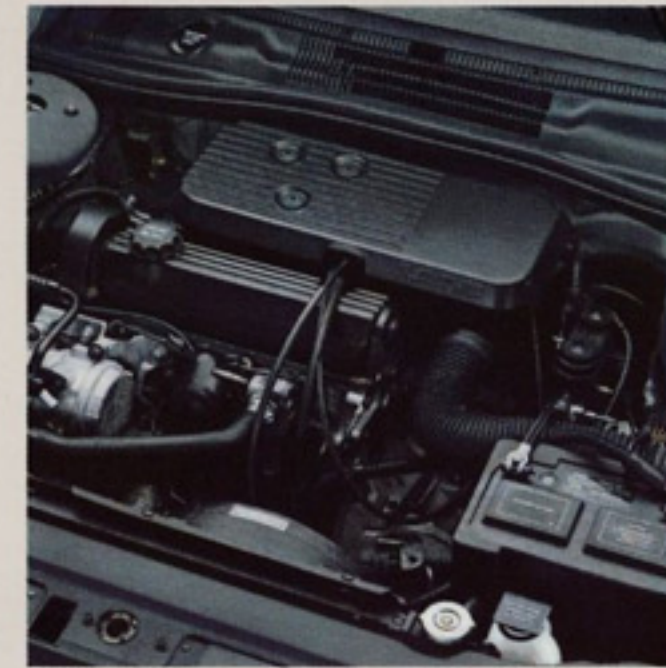

Acclaim's standard 2.5-liter dual balance-shaft EFI four-cylinder engine. Underhood service points are clearly labeled for easy maintenance.



Acclaim interior comfort, with controls that are close at hand, shown in Bordeaux.



Plymouth Acclaim, shown in Claret Red Pearl Coat.

Today is the right time for the new 1989 Plymouth Acclaim. Full-size roominess in a midsize car and more than 50 standard features help make driving easier, safer, and more satisfying.

A smooth-shifting five-speed manual transaxle and quick-ratio power-assisted steering and power-assisted brakes offer precise control. A two-coaxial speaker AM stereo*/FM stereo radio and acoustical sound insulation pamper your ears. While cloth low-back reclining bucket seats with adjustable head restraints ease the miles. Extensive use of galvanized exterior lower body panels and a stainless steel exhaust system give lasting protection.

*Some AM stereo broadcasting may not be compatible with this radio.

FEATURES

With more than 50 standard features, Plymouth Acclaim gives you equipment that costs extra or is unavailable in other midsize sedans.

(A) Easy-operating counterbalanced hood opens high for convenient access. Inside release lever provides security.

(B) Inside fuel door and deck lid release provide convenience and protection. Tethered fuel cap helps prevent accidental loss.

(C) Five-speed manual transaxle with improved synchronizers is smooth shifting, and has overdrive to help improve highway mileage on Acclaim and Acclaim LE.

(D) Analog instrumentation includes electric speedometer and tachometer, trip odometer, and gauges for electrical system voltage, engine oil pressure, engine temperature, and fuel level. Standard on all models.

(E) Reclining bucket seats, driver's side adjustable lumbar support, and adjustable head restraints are standard on Acclaim LE and LX.

(F) Reversible valet key operates the door and ignition only. Separate reversible master key operates all locks on car.

(G) Twin cup holders in console armrest serve rear seat passengers. (Standard on Acclaim LE and LX, available on Highline Acclaim.)

(H) Intermittent windshield wipers have fast, slow, and variable intermittent cycles. Wipers are semi-concealed for beauty and aerodynamic efficiency.

(I) Low liftover trunk height allows easy package loading. Flat trunk floor conceals spare tire. Deck lid opens high for maximum head room, trunk access.

(J) Fourteen-inch turbine wheel covers (set of four; see photo [A]).

(K) Stainless steel exhaust system fights corrosion. (Not shown.)

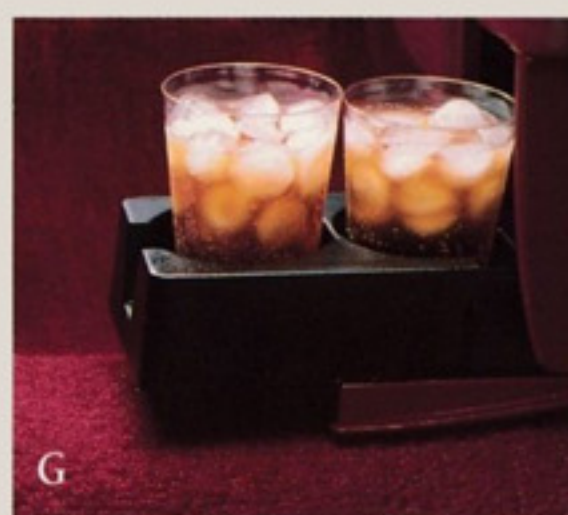
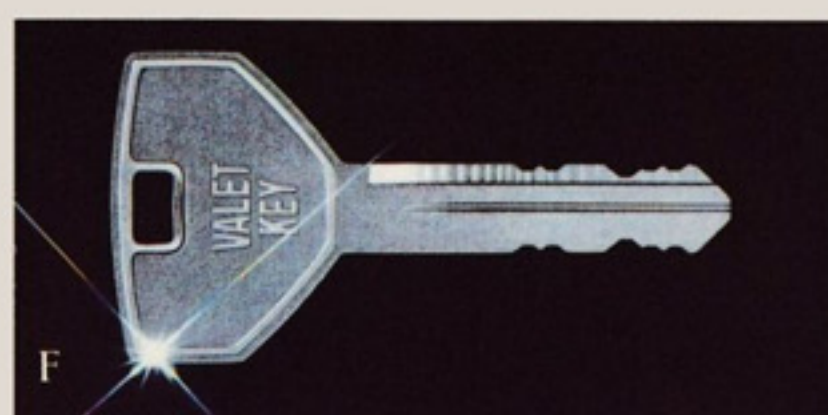
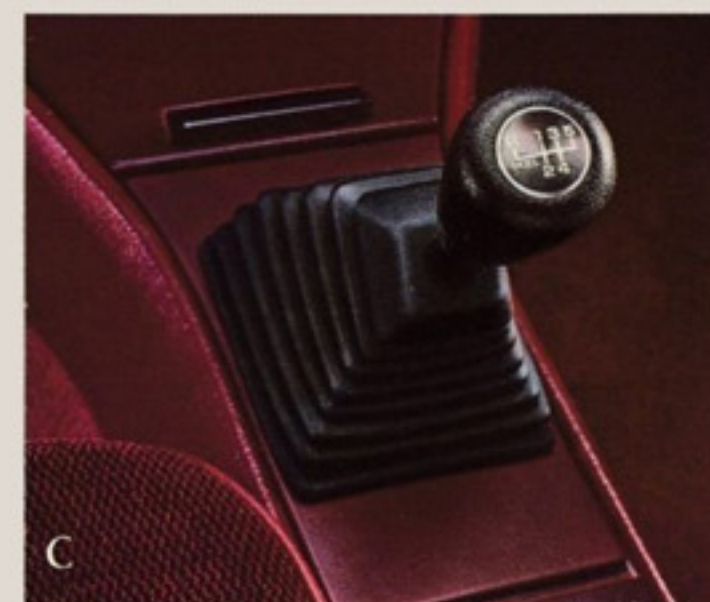

OPTIONS

Available equipment from Plymouth personalizes Acclaim while satisfying your driving needs. (See Technical Guide in the back of this catalog for complete option details and optional packages.)

(A) AM stereo*/FM stereo radio with cassette tape player (see page 20 for all sound system details).

(B) Chrysler Infinity I Sound System.

(C) Chrysler Infinity II Sound System.

(D) Electronic speed control reduces driver fatigue and helps improve fuel economy. Cancels automatically when traction is lost, brakes are applied, or clutch is disengaged.

(E) Tilt steering adjusts for comfort and control. Lever allows easy adjustment.

(F) Air conditioning† keeps passengers cool with bi-level ventilation, high-capacity fan.

(G) Dual heated power remote controlled rearview mirrors allow easy adjustment and help remove snow and ice during winter driving.

(H) Sun roof with sun shade may be removed or flipped up in back to allow ventilation. Removable shade reduces solar heating of interior.

(I) Electric rear window defroster‡ melts frost, clears condensation to enhance rear visibility.

(J) Six-way power driver's seat adjusts to different drivers.

(K) Turbo I engine gives Acclaim 150 horsepower for brisk acceleration, passing, and performance. Turbo I is based on Plymouth's 2.5-liter balance-shaft four-cylinder multipoint EFI engine.

(L) Power windows and door locks offer convenience and security.

*Some AM stereo broadcasting may not be compatible with this radio.
†There are special engine cooling requirements for field-installed air conditioning. Failure to follow these requirements may invalidate warranty. See your dealer for details.

‡Required on all passenger vehicles registered in New York state.

ENGINEERING

Creating new Plymouth Acclaim took more than engineers and designers. Plymouth researched and listened to car owners like you. Acclaim is the result of that exhaustive research. We think you'll find that Acclaim's performance and refinement make it one of today's most exciting sedans.

The Acclaim and Acclaim LE standard smooth-running 2.5-liter four-cylinder engine features dual counter-rotating balance shafts, single-point electronic fuel injection, and Phase II Quiet Idle features to reduce engine noise.

The standard engine and the 2.5-liter Turbo I engine* have stronger main bearing caps for smoothness and durability.

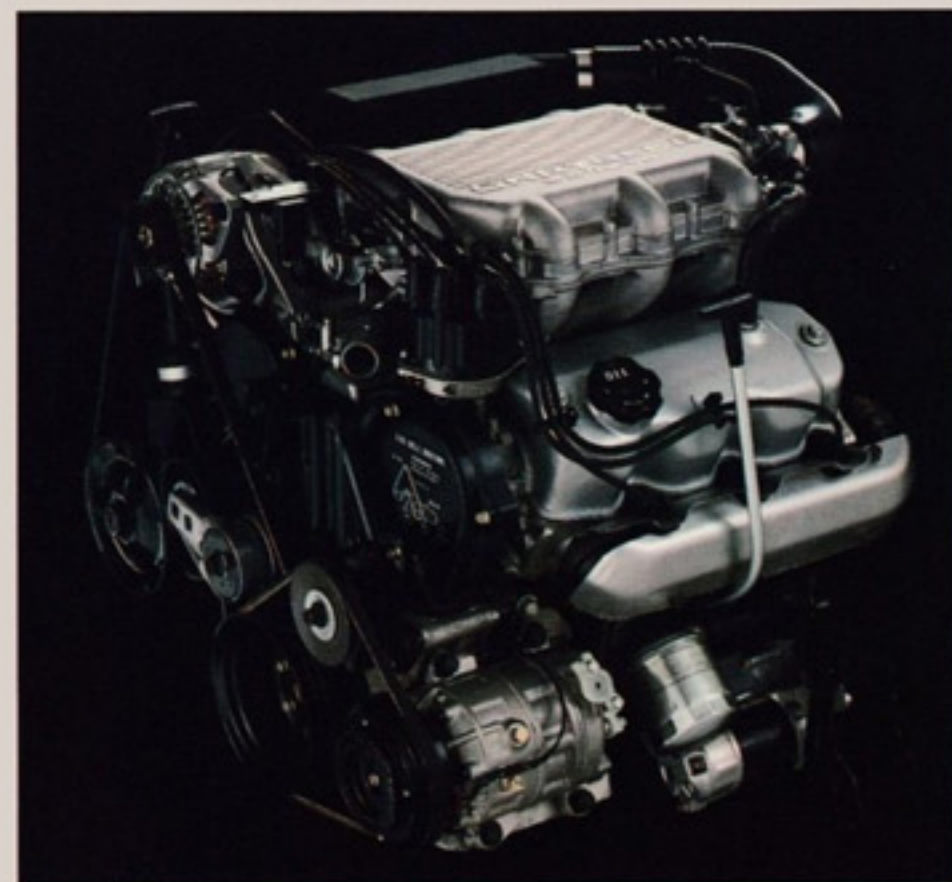

Acclaim LX's standard 141-horsepower 3.0-liter V-6* with high-tech light alloy aluminum cylinder heads, overhead camshafts, and multipoint fuel injection.

Ultradrive Automatic Transaxle

Lockup torque converter is actuated by the transaxle control computer.

Sealed 40-way connector ties Ultradrive to its state-of-the-art transaxle control computer that reads Acclaim's engine-operating parameters from the single module engine controller, then determines ideal gear ratio and shift points electronically.

A unique logic-controlled switching valve eliminates shifting conflicts.

Ultradrive uses only clutches to change gear ratios for smooth, consistent shifts.

P, R, N, Od, D, and L shift quadrant gives you precise control of four forward gear ratios.

Solenoids operate the clutches directly for maximum reliability.

Acclaim LX's standard Ultradrive electronic fully adaptive automatic four-speed overdrive transaxle is the first of its kind. This all-new transaxle allows smooth, crisp shifting, quick acceleration, and excellent fuel economy.†

The high-tech Ultradrive transaxle uses fewer parts than previous transaxle designs and has higher torque capacity, with a lockup overdrive fourth gear that is quiet at

cruising speeds. Sensors that monitor Acclaim LX's 3.0-liter V-6 engine* communicate with special transaxle control electronics to determine upshift and downshift points.

Meticulously designed and proven by countless miles of driving and hours of laboratory testing, every Ultradrive transaxle receives thorough testing and calibration at the factory to ensure refined performance.

*See page 22 for further engine information.
†See your dealer for mpg ratings.

Aerodynamic Styling. Dampens wind noise and helps improve fuel economy.* Flush windshield and backlight, semi-flush side windows, aerodynamic headlights, integrated bumpers, and outside rearview mirrors. Galvanized steel exterior body panels (except roof) provide maximum corrosion protection.

Suspension. Standard nitrogen-charged position-sensitive strut front/rear shock suspension has increased rebound damping and coil spring isolator cushions. Beam axle rear trailing arm suspension with integral antisway bar offers smooth ride, agile handling.

Energetic Engines. Acclaim and Acclaim LE have the 2.5-liter electronically fuel-injected dual balance-shaft four-cylinder engine with Phase II Quiet Idle feature. A 2.5-liter Turbo I engine is available in Acclaim and Acclaim LE. Acclaim LX standard 3.0-liter V-6 MPI engine† has overhead camshaft.

Five-Speed Overdrive Manual Transaxle. Standard with floor-mounted shifter on Acclaim and Acclaim LE. Overdrive fifth gear promotes quiet, high-efficiency cruising.* A three-speed automatic (with lockup torque converter for 2.5-liter engine only) is optional. The new Ultradrive electronically adaptive four-speed automatic overdrive transaxle is standard on Acclaim LX.

PLYMOUTH ACCLAIM TECHNICAL INFORMATION

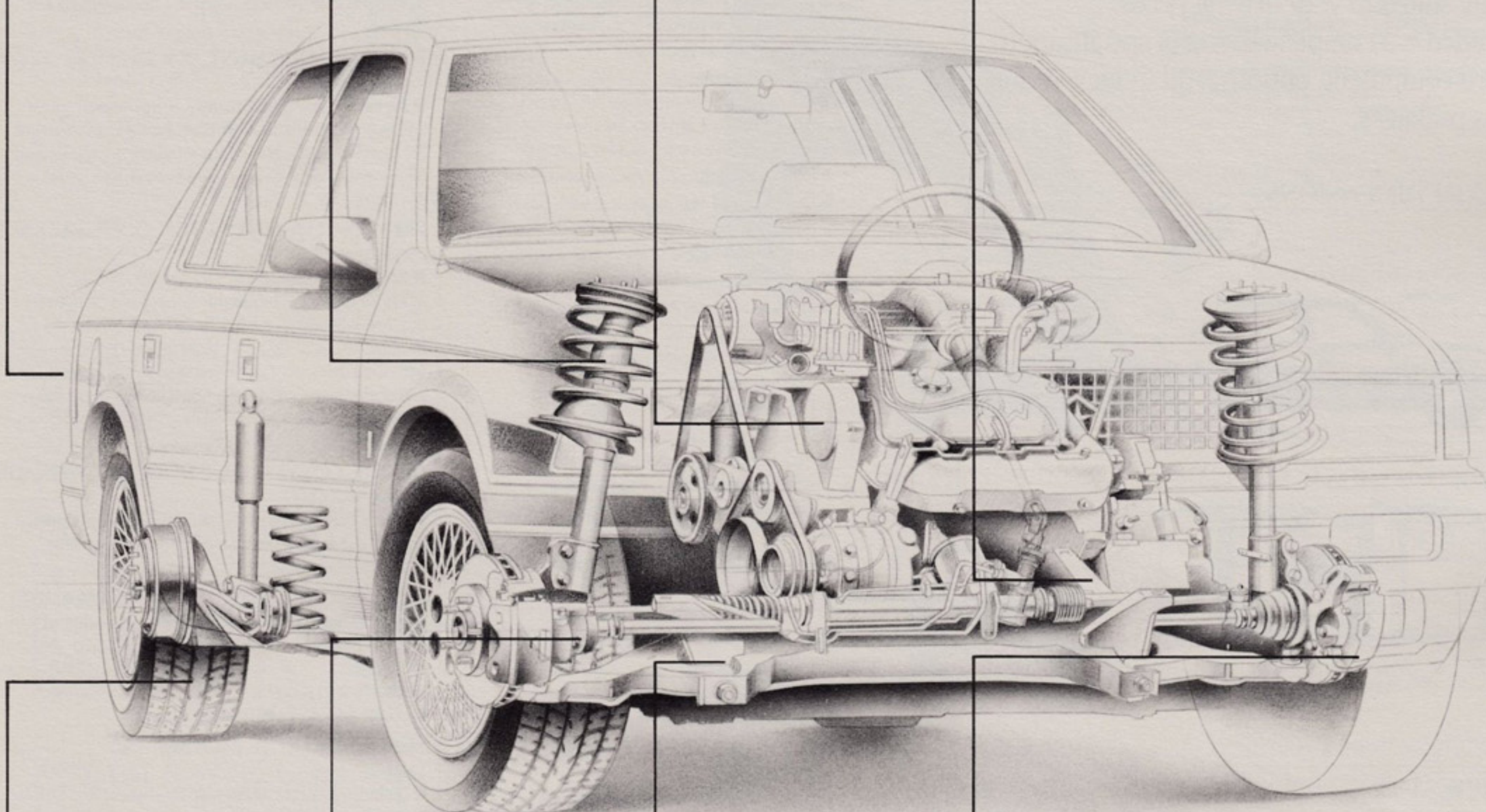

All-Season Touring Tires (set of four). P185/70R14 all-season touring tires with a new low-noise tread pattern. Standard on Acclaim. Acclaim LE's P195/70R14 tires have the same quiet tread. All-season P205/60R15 performance tires are standard on Acclaim LX for improved handling and responsiveness.

Front-Wheel Drive. New Acclaim has proven front-wheel drive for all-season traction and stability.

Power-Assisted Rack-and-Pinion Steering. Gives you precise road feel with modest steering effort, standard on every Acclaim.

Power-Assisted Brakes. Acclaim's standard power-assisted front discs are vented for rapid heat dissipation, rear drums are self-adjusting and vacuum-boosted. Master cylinder has two separate circuits for added safety.

*See your dealer for mileage figures.
†See page 22 for further engine information.

TECHNICAL

This Technical Guide provides all the facts you'll need to purchase the new Plymouth Acclaim that's perfectly suited to your driving needs.

Included is a complete listing of specifications, standard equipment, options, and money-saving options packages.

ACCLAIM DIMENSIONS

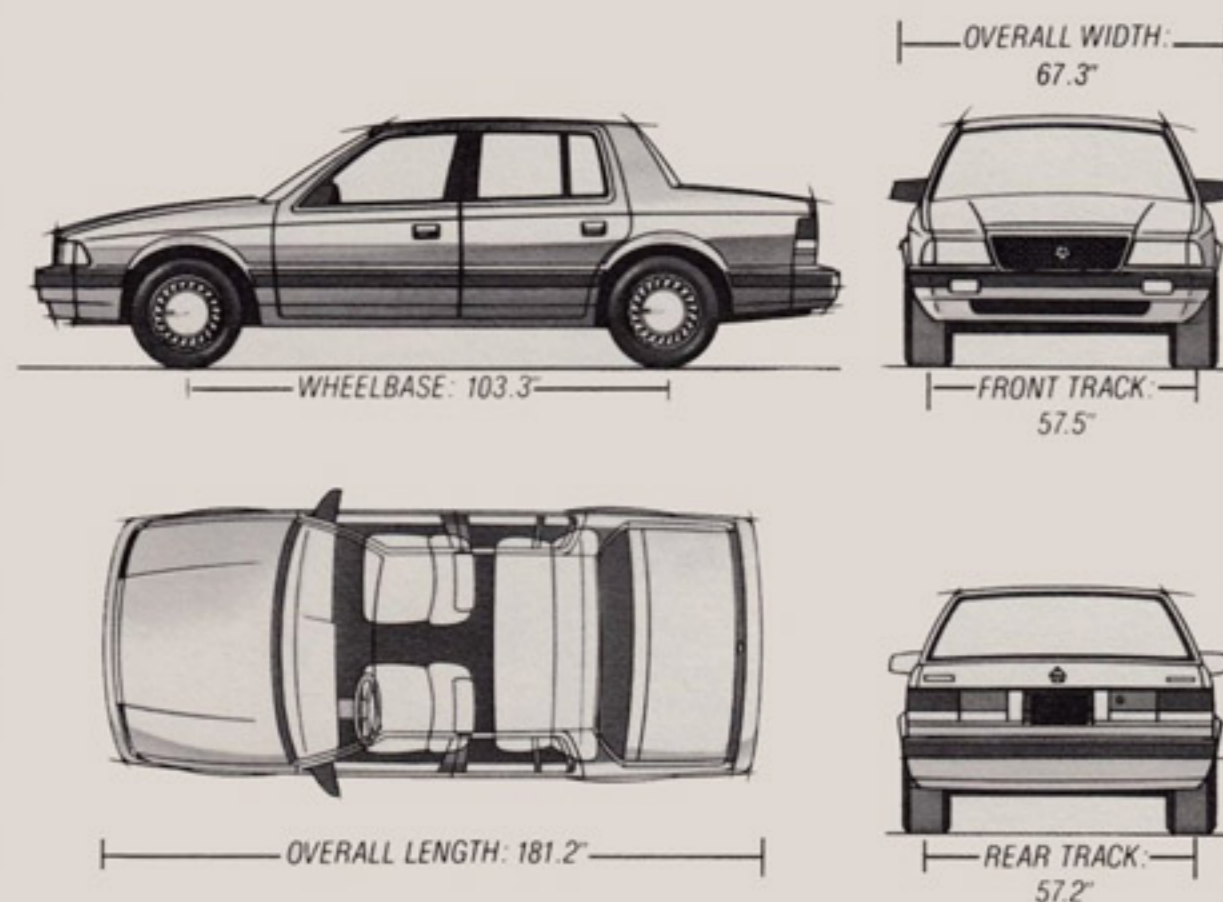

SPECIFICATIONS

Head Room—Front	38.4"
—Rear	37.9"
Leg Room—Front (maximum)	41.9"
—Rear (minimum)	38.3"
Hip Room—Front	51.7"
—Rear	52.0"
Shoulder Room—Front	54.3"
—Rear	54.9"
Trunk Capacity (estimated)	14.4 cu ft
Turning Diameter—Curb-to-Curb	37.6'
Curb Weight with Standard Engine (estimated)	Acclaim 2,753 lb
	Acclaim LE 2,827 lb
	Acclaim LX 2,968 lb

STANDARD SAFETY FEATURES

- Antitheft trunk lock
- Backup lights
- Brake fluid pressure loss warning light (also serves as parking brake indicator)
- Childproof rear door locks
- Combination lap/shoulder belts for the driver, right front passenger, and outside rear passengers; lap belts for all others; includes provision for child seat tethers
- Double ball-joint rearview mirror mount
- Dual diagonal braking system with separate brake fluid reservoirs in the master cylinder
- Electric windshield washers and wipers
- Energy-absorbing front seatbacks
- Energy-absorbing instrument panel and sun visors
- Energy-absorbing steering column and/or steering wheel
- Fade-resistant front vented disc brakes
- Front seat head restraints
- Glare reduction measures for instrument panel, steering wheel, windshield wipers, and windshield header and roof
- Hazard warning flasher system
- Headlight and wiper circuit breakers with automatic reset
- Ignition and steering column lock
- Impact-actuated fuel supply shutdown relay
- Inside and outside rearview mirrors
- Interlocking door latches
- Key left in ignition warning
- Non-override door locks (except driver's door)
- Recessed inside door release handles
- Reinforced windshield header and roof
- Resilient window crank knobs
- Safety glass
- Safety-Rim wheels
- Seat belt reminder system
- Side door beams
- Side marker lights and/or reflectors
- Squeeze glove box latch
- Supplemental center high-mounted stoplight
- Turn signals with lane-change feature and flashing front side marker lights

OPTIONS PACKAGES

BASIC EQUIPMENT DISCOUNT PACKAGE (Acclaim only.)

- Armrest mounted on standard console (available with bucket seats only; includes dual cup holders for rear seat passengers)*
- Two additional rear-mounted coaxial speakers†

POPULAR EQUIPMENT DISCOUNT PACKAGE (Acclaim only.)

- Air conditioning with manual temperature control and bi-level ventilation**
- Basic Equipment Discount Package
- Electric rear window defroster (required on all passenger vehicles registered in New York state)
- Tinted glass, all windows*

PREMIUM EQUIPMENT DISCOUNT PACKAGE (Acclaim only.)

- Graphic message center*: includes warning lights for door ajar; headlight, stoplight or taillight out; low windshield washer fluid; trunk lid ajar
- Light Package: includes lights for cigar lighter; ignition switch with time delay; roof-mounted map light;‡ underhood,* and under-instrument-panel-mounted courtesy lights*
- Premium body sound insulation* ■ Split fold-down rear seatback*

DELUXE CONVENIENCE DISCOUNT PACKAGE (Acclaim only.)

- Electronic speed control* ■ Front and rear carpeted floor mats* ■ Ignition switch light with time delay*
- Tilt steering column*

POWER EQUIPMENT DISCOUNT PACKAGE (Available on all models. Air conditioning required. Popular Equipment Discount Package required on Acclaim.)

- Dual heated power remote control black mirrors*
- Power door locks ■ Power windows*

SUPER DISCOUNT PACKAGE "A" (Acclaim only.)

- Includes contents of Popular Equipment and Deluxe Convenience Discount Packages.

SUPER DISCOUNT PACKAGE "B" (Acclaim only.)

- Includes contents of Popular Equipment, Deluxe Convenience, and Power Equipment Discount Packages.

SUPER DISCOUNT PACKAGE "C" (Acclaim LE and LX only.)

- Includes contents of Power Equipment Discount Package, plus air conditioning.
- *Available in package only.
- †Available in package or with radio upgrade.
- **There are special engine cooling requirements for field-installed air conditioning. Failure to follow these requirements may invalidate warranty. See dealer for details.
- ‡Available with sun roof.

OPTIONS PACKAGES

Options packages save you money and let you equip your new Acclaim to meet your driving comfort and convenience needs. You'll find your favorite automotive equipment packaged and priced below the individual option cost.

ACCLAIM PACKAGES	Acclaim	Acclaim LE	Acclaim LX
Basic Equipment Discount Package	O	S	S
Popular Equipment Discount Package	O	S ³	S ³
Premium Equipment Discount Package	O	S	S
Deluxe Equipment Discount Package	O	S	S
Power Equipment Discount Package	O ^{1,2}	O ²	O ²
Super Discount Package "A"	O	NA	NA
Super Discount Package "B"	O	NA	NA
Super Discount Package "C"	NA	O	O

O—Optionally available. S—Standard equipment. NA—Not available.
¹Popular Equipment Discount Package required.
²Air conditioning required.
³Air conditioning extra cost.

ACCLAIM TOWING CAPACITIES

Engine	Transaxle	Towing Capacity
2.5-liter	5-speed manual	1,000 lb
2.5-liter	3-speed automatic	2,000 lb
3.0-liter*	Ultradrive	2,000 lb

*See page 22 for further engine information.
 NOTE: Optional 2.5-liter turbocharged engine not recommended for trailer towing, and such use may damage engine and invalidate warranty. See dealer for details.

CORROSION PROTECTION

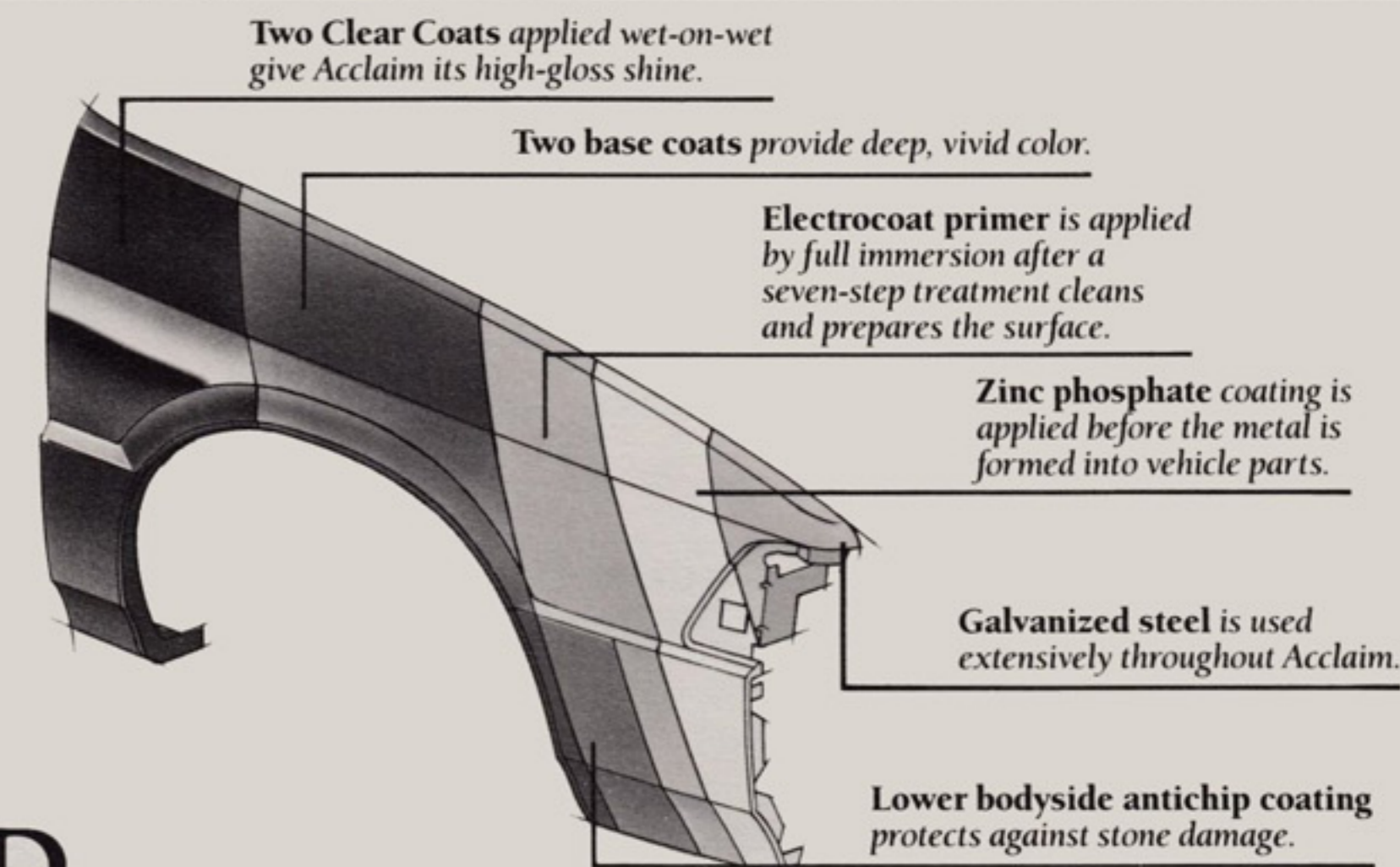

Plymouth Acclaim's design and manufacture include some of today's most comprehensive anticorrosion measures.

Galvanized steel body panels are coated with zinc-rich primer even before the metal is formed; and every Acclaim receives a seven-step full-immersion treatment that cleans and prepares the metal surface to help paint adhesion.

The body is then fully submerged and electrocoated with highly corrosion-resistant epoxy base coat paint primer, followed by a coat of high-gloss acrylic enamel, oven-baking, and sanding. Then come two coats of colored acrylic

enamel, and another two coats of acrylic Clear Coat enamel.

The result? A beautiful, durable high-gloss finish with deep, vivid color, and a "just-waxed" look that resists chipping, fading, weathering, and corrosion.

Additional corrosion-fighting features include fiberglass, plastics, and construction design that prevents the corrosive electrolytic action caused by contact between different metals.

Quality manufacturing and design. That's why Plymouth backs Acclaim with the powerful protection of a seven-year/100,000-mile Anticorrosion Limited Warranty.

ACCLAIM STANDARD AND OPTIONAL EQUIPMENT

	ACCLAIM	ACCLAIM LE	ACCLAIM LX
FUNCTIONAL			
Alternator—90-ampere	S	S	S
Battery—500-ampere, maintenance-free; with test indicator	S	S	S
Brake—Parking: foot-pedal-operated	S	S	S
Brakes—Dual diagonal, disc front, self-adjusting drum rear: power-assisted	S	S	S
Coolant Overflow Reservoir	S	S	S
Electronic Ignition, Voltage Regulator, and Fuel Injection	S	S	S
Emissions Controls and Testing—Required at extra cost on all vehicles registered in California; not available otherwise	O	O	O
Engines and Systems—(See Power Train Chart—page 22)	—	—	—
Front-Wheel Drive	S	S	S
Fuel Tank—16-gallon; with curbside fuel filler door	S	S	S
Steering—Rack-and-pinion, fast-ratio (14:1), precision-feel: power-assisted	S	S	S
Suspension—Front gas-charged position-sensitive struts and solid antisway bar; rear beam axle with trailing arms, tubular antisway bar, and gas-charged shock absorbers	S	S	S
Tire—Spare: compact, limited service, T125/70D14	S	S	S
Tire—Spare: conventional, P185/70R14 or P195/70R14	O	O	NA
Tires—P185/70R14 steel-belted radial all-season touring tread design black sidewall (set of four)	S	NA	NA
Tires—P195/70R14 steel-belted radial all-season touring tread design black sidewall (set of four)	O ¹	S	NA
Tires—P205/60R15 steel-belted radial all-season performance tread design low black letter (set of four)	NA	NA	S
Wheel Covers—Lace: 14-inch (set of four)	NA	S	NA
Wheel Covers—Turbine: 14-inch (set of four)	S	NA	NA
Wheels—Road: cast aluminum 15-inch (set of four)	NA	NA	S
EXTERIOR			
Bumpers—Energy-absorbing: color-keyed, with protective rub strips	S	S	S
Corrosion Protection—Extensive use of galvanized steel	S	S	S
Fog Lights—Integral in front fascia	NA	NA	S
Fuel Filler Cap Tether	S	S	S
Halogen Headlights—Aero-style	S	S	S
Hood—Counterbalanced	S	S	S
Mirrors—Dual remote control: black	S	S	S
Moldings—Belt (bright/black); door center pillars (black); upper door frame and belt (bright/black); windshield and rear window (black)	S	S	S

	ACCLAIM	ACCLAIM LE	ACCLAIM LX
EXTERIOR (Cont.)			
Moldings—Bodyside bumper protective rub strip extensions, grooved with bright edge	S	S	NA
Moldings—Bodyside bumper protective rub strip extensions (body color with bright edge)	NA	NA	S
Moldings—Lower bodyside cladding (bright upper/grooved Quartz color lower); narrow bodyside (body color with bright insert); sill (black); wheel lip, full (bright)	NA	S	S
Moldings—Wide bodyside, grooved with bright edge	S	NA	NA
Stripes—Bodyside: paint	S	NA	NA
Stripes—Bodyside and deck lid: paint	NA	S	S
Sun Roof—Removable, flip-up: includes air deflector, cargo compartment tie-down straps, removable sun shade, and vinyl storage bag	O ²	O	O
Urethane Protective Coating—Lower body	S	S	S
INTERIOR			
Acoustical Package—Insulation: body sound	S	S	S
Acoustical Package—Premium: body sound	P	S	S
Air Conditioning—Manual temperature control: with bi-level ventilation ³	P	O	O
Armrests—Center console mounted: storage bin and dual cup holder for rear passengers included	P	S	S
Armrests—Door mounted: two front, two rear	S	S	S
Ash Receivers—One front, two rear	S	S	S
Carpeting—Passenger compartment: color-keyed	S	NA	NA
Carpeting—Premium: low pile, color-keyed	NA	S	S
Carpeting—Trunk floor and sidewall	S	S	S
Chimes—Warning: fasten seat belt, headlights on, key in ignition	S	S	S
Cigar Lighter	S	S	S
Clock—Electronic digital (integral with radio)	S	S	S
Coat Hooks—Two rear	S	S	S
Console—Full floor: with cassette storage and garage door opener storage, coin-holder, covered bin, front cup holder	S	S	S
Cubby Bin—Instrument panel; open: flocked	S	NA	NA
Deck Lid Release—Cable-operated remote control; defeat mechanism located in trunk	S	S	S
Defroster—Rear window: electric (required on all passenger vehicles registered in New York state)	O	S	S
Demisters—Side window	S	S	S
Door Locks—Power	O	O	O
Door Release Handles—Interior: easy-open, with plunger type lock/unlock system	S	S	S
Floor Mats—Front and rear: carpeted	P	S	S

ACCLAIM STANDARD AND OPTIONAL EQUIPMENT

	ACCLAIM	ACCLAIM LE	ACCLAIM LX
INTERIOR (Cont.)			
Fuel Filler Door Release—Cable-operated remote control; override located in trunk	S	S	S
Glove Box—Lockable; includes storage for cassette tapes	S	S	S
Head Restraints—Front: two-way adjustable	S	S	S
Heater and Defroster—With bi-level ventilation and side window demisters	S	S	S
Hood Release—Inside	S	S	S
Horn—Single	S	NA	NA
Horns—Dual	NA	S	S
Instrument Cluster—Electric analog speedometer (120 mph) with secondary metric scale; electromechanical tachometer, odometer, trip odometer; gauges for electrical system voltage, engine coolant temperature, engine oil pressure, and fuel level; warning lights for brake system failure or parking brake on, check engine, check gauges, fasten seat belts, low fuel, low oil pressure	S	S	S
Key—Reversible: double bitted, with valet feature	S	S	S
Lights—Ash receiver, dome, front and rear door switches for dome light, glove box, trunk	S	S	S
Lights—Cigar lighter, ignition switch with time delay, instrument panel-mounted courtesy, map light, underhood	P	S	S
Locks—Interior rear doors: childproof	S	S	S
Message Center—Graphic: includes warning lights for door ajar, headlight out, low windshield washer fluid, stoplight out, taillight out, trunk lid ajar	P	S	S
Mini Travel Trip Computer—Includes average and instant miles per gallon, distance to empty, trip odometer, elapsed time: U.S. and metric readout	NA	NA	S
Mirror—Rearview day/night	S	S	S
Mirrors—Dual visor vanity	S	NA	NA
Mirrors—Dual visor vanity: illuminated	NA	S	S
Multifunction Control Lever—Mounted on steering column: includes controls for turn signals with lane change feature, headlight dimmer, and day/night flash/pass feature; windshield wiper/washer; controls for electronic speed control if applicable	S	S	S
Radio—AM stereo ⁴ /FM stereo: electronically tuned; Dynamic Noise Reduction ⁵ ; four coaxial speakers on Acclaim LE, two front coaxial speakers on Acclaim; integral digital clock	S	S	NA
Radio—AM stereo ⁴ /FM stereo: electronically tuned; Dynamic Noise Reduction ⁵ ; cassette tape player with automatic reverse; four coaxial speakers; integral digital clock	O	O	S

	ACCLAIM	ACCLAIM LE	ACCLAIM LX
INTERIOR (Cont.)			
Radio—Chrysler Infinity I Sound System AM stereo ⁴ /FM stereo: electronically tuned; memory scan, up-and-down seek-and-scan, Dynamic Noise Reduction ⁵ ; electronic cassette tape player with automatic reverse, true fast forward and rewind, automatic metal tape sensor, tape program music search, Dolby B ⁶ Noise Reduction, joystick balance/fader speaker control; Chrysler Infinity vehicle-equalized eight-speaker system; integral digital clock	O ²	O	O
Radio—Chrysler Infinity II Sound System AM stereo ⁴ /FM stereo: electronically tuned; with memory scan, up-and-down seek-and-scan, Dynamic Noise Reduction ⁵ ; electronic cassette tape player with automatic reverse, true fast forward and rewind, automatic metal tape sensor, tape program music search, Dolby B ⁶ Noise Reduction, five-band electronic graphic equalizer, joystick balance/fader speaker control; Chrysler Infinity vehicle-equalized eight-speaker system; integral digital clock	NA	O	O
Seat Belts—Unibelt, with automatic retractor on front and rear outboard seats, lap belts at all other positions: color-keyed	S	S	S
Seats—Front: cloth low-back bucket with reclining seatbacks and two-way adjustable head restraints	S	NA	NA
Seats—Front: cloth low-back bucket with reclining seatbacks and adjustable head restraints; driver's side manual lumbar support adjustment	NA	S	S
Seats—Front: cloth 50/50 split bench with individual armrests ⁷	O	NA	NA
Seats—Front: power, left side of 50/50 split bench or driver's side bucket	O ²	O	O
Seats—Front: premium cloth 50/50 split bench with individual armrests ⁷	NA	O	O
Seats—Rear: cloth bench	S	NA	NA
Seats—Rear: cloth, folding seatback, split 55/45; lockable latches	P	S	S
Speed Control—Electronic	P	S	S
Steering Column—Tilt	P	S	S
Steering Wheel—Deluxe two-spoke: color-keyed	S	S	NA
Steering Wheel—Luxury two-spoke: leather-wrapped	NA	NA	S
Visors—Driver and passenger side	S	S	S
Visors—Dual vanity with mirror: covered	S	NA	NA
Visors—Dual vanity with mirror: illuminated	NA	S	S
Windshield Wipers—Deluxe; with variable intermittent wipe feature	S	S	S

S—Standard. O—Optionally available. P—Package only. NA—Not available.
¹Required and available with 2.5-liter turbocharged engine option only.
²Popular Equipment Discount Package required.
³There are special engine cooling requirements for field-installed air conditioning. Failure to follow these requirements may invalidate warranty. See your dealer for details.
⁴Some AM stereo broadcasting may not be compatible with this radio.
⁵Dynamic Noise Reduction is a trademark of National Semiconductor Corporation.
⁶Dolby B is a trademark of Dolby Laboratories.
⁷Column-mounted shifter replaces console-mounted shifter and console. Includes instrument-panel-mounted cup holders/ashtray.

TECHNICAL

Type	Displacement	Bore & Stroke	Compression Ratio	Horsepower/Torque		Transaxle Availability
				SAE Net @ RPM	@ RPM	
4-cylinder EFI engine	2.5-liter (153 CID)	3.44" x 4.09"	8.9:1	100 hp @ 4,800	135 lb-ft @ 2,800	5-speed close-ratio manual overdrive (2.51 OTGR): standard on Acclaim and Acclaim LE; not available on Acclaim LX 3-speed automatic ⁴ (3.02 OTGR): optional on Acclaim and Acclaim LE; not available on Acclaim LX
4-cylinder turbocharged multipoint EFI engine (Turbo I) ²	2.5-liter (153 CID)	3.44" x 4.09"	7.8:1	150 hp @ 4,800	180 lb-ft @ 2,000	5-speed close-ratio manual overdrive (2.51 OTGR): optional on Acclaim ⁵ and Acclaim LE; not available on Acclaim LX 3-speed automatic (3.02 OTGR): optional on Acclaim ⁵ and Acclaim LE; not available on Acclaim LX
6-cylinder multipoint EFI engine ³	3.0-liter (181 CID)	3.59" x 2.99"	8.9:1	141 hp @ 5,000	171 lb-ft @ 2,800	4-speed automatic ⁶ (2.36 OTGR): standard on Acclaim LX; not available on Acclaim and Acclaim LE

OTGR—Overall top gear ratio. ¹California emissions controls and testing required at extra cost on all vehicles registered in California. Not available otherwise. ²Premium unleaded fuel recommended. Trailer towing is not recommended for vehicles equipped with turbocharged engine, and such use may damage engine and invalidate warranty. ³Manufactured by Mitsubishi Motors Corporation. ⁴Includes electromechanical lockup torque converter. ⁵P195/70R14 tires and Popular Equipment Discount Package required. ⁶Includes electronically controlled lockup torque converter.

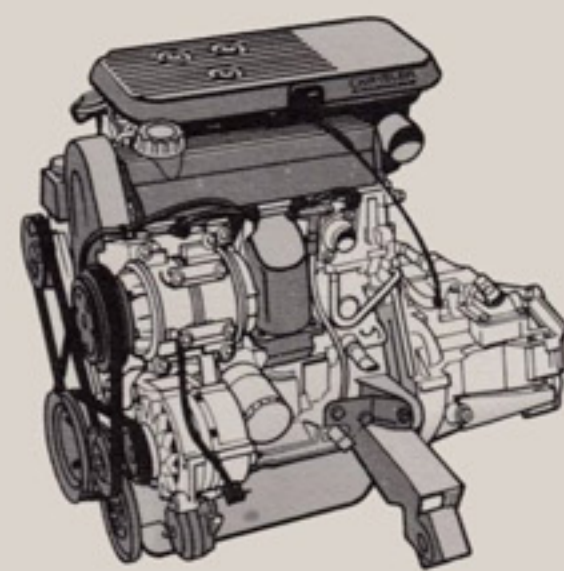

2.5-LITER EFI DUAL BALANCE-SHAFT ENGINE

The Acclaim and Acclaim LE standard 2.5-liter dual balance-shaft engine includes electronic fuel injection for optimal fuel metering and usage. The engine includes an overhead camshaft with roller tappets and counter-rotating balance shafts for smooth operation. A five-speed manual transaxle is standard, and a three-speed automatic transaxle is optional.

*Turbocharged engines are not recommended for trailer towing, and such use may damage engine and invalidate warranty.
† Manufactured by Mitsubishi Motors Corporation.

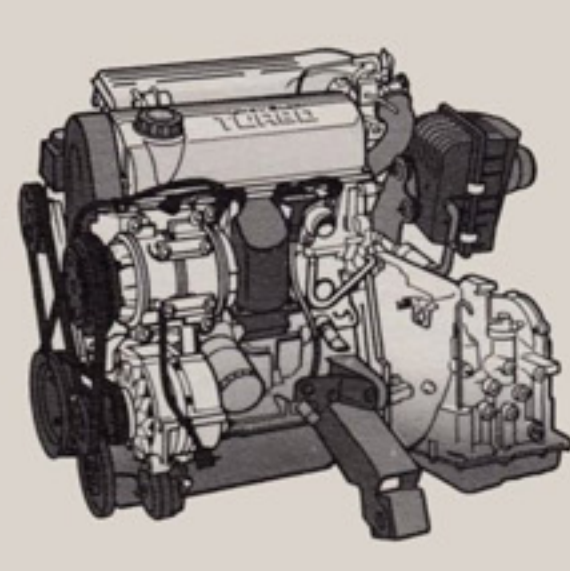

2.5-LITER TURBOCHARGED MPI ENGINE

Available in Acclaim and Acclaim LE, the 2.5-liter Turbo I* MPI engine features a single overhead camshaft design with dual counter-rotating balance shafts and a low-inertia turbine and compressor for higher sustained peak acceleration, substantial low-end torque, and quiet, low-vibration idle. Five-speed manual transaxle standard, three-speed automatic transaxle optional.

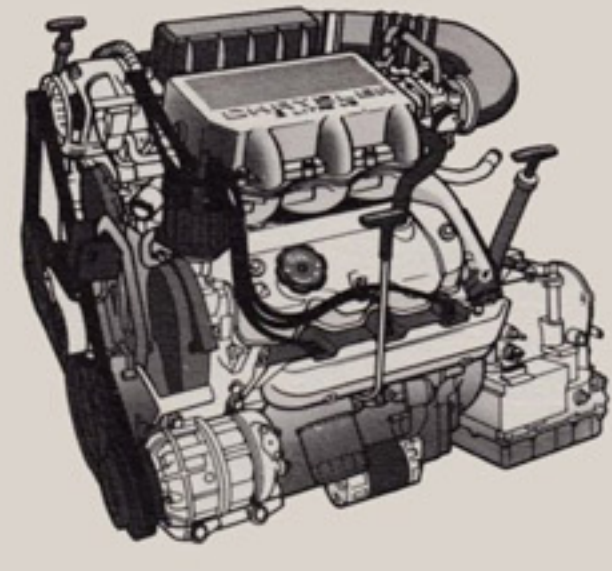

3.0-LITER V-6 MPI ENGINE†

This 3.0-liter V-6 MPI engine† is standard equipment on Acclaim LX. Contemporary features include a light alloy cast iron block and aluminum cylinder heads, belt-driven overhead camshafts, electronic multipoint fuel injection, and a long-life serpentine accessory drive belt. The new Ultradrive electronic fully adaptive four-speed overdrive automatic transaxle is standard. (See page 16 for details.)

EXTERIOR	INTERIOR
Black Clear Coat	Bordeaux, ⁴ Taupe, ⁵ Medium Quartz*
Black Cherry Pearl Coat	Bordeaux
Diamond Blue Clear Coat*	Twilight Blue
Twilight Blue Pearl Coat†	Twilight Blue
Dark Gray Quartz Clear Coat*	Medium Quartz
Claret Red Pearl Coat**	Bordeaux
Platinum Silver Clear Coat**	Medium Quartz
Medium Taupe Clear Coat*	Taupe
Light Taupe Clear Coat**	Taupe
Bright White Clear Coat	Bordeaux, ⁴ Twilight Blue, ⁵ Taupe, ⁵ Medium Quartz

*Acclaim and Acclaim LE only.
†Extra cost on Acclaim and Acclaim LE. No charge on Acclaim LX.
‡Extra cost.
§Acclaim only.
§Acclaim and Acclaim LX only.

SIZE	TYPE (set of four)	AVAILABILITY
P185/70R14	Steel-belted radial all-season touring tread design black sidewall	Standard Acclaim
P195/70R14	Steel-belted radial all-season touring tread design black sidewall	Standard Acclaim LE; required and available only with Turbo II engine on Acclaim
P205/60R15	Steel-belted radial all-season performance tread design low black letter	Standard Acclaim LX
T125/70D14	Compact-type spare (one)	Standard
P185/70R14 P195/70R14	Matching-type conventional-type spare (one)	Optional Acclaim and Acclaim LE; not available Acclaim LX

EXTERIOR COLORS



*Acclaim and Acclaim LE only.
†Extra cost on Acclaim and Acclaim LE. No charge on Acclaim LX.
NOTE: Due to printing limitations, the colors shown will vary slightly from actual hues. See your Plymouth dealer for actual color chips.

Quality Worth Backing



All Chrysler Motors automobiles and light trucks now benefit from the 7/70 Limited Warranty. Upon expiration of the basic 12-month or 12,000-mile limited warranty, coverage is extended on power train components to seven years or 70,000 miles.* This represents one of the most comprehensive original limited warranties available on cars and trucks built and sold in the United States, and points out Chrysler Motors' pride in building and backing its products the right way.

In addition to the 7/70 Limited Warranty described above, Chrysler Motors automobiles offer the 7/100 Anticorrosion Limited Warranty. Your dealer will repair or replace at no charge outer body sheet metal panels found to have developed perforation (rust-through) in normal use up to seven years or 100,000 miles. See your dealer for a copy of the limited warranty.

*A deductible applies. See your dealer for a copy of the warranty.

Chrysler Purchase Assistance Program For The Physically Challenged
Cash reimbursements of up to \$500 are available for qualified adaptive driving devices on 1989 Chrysler Motors cars and trucks. For further information, contact your dealer or the PHYSICALLY CHALLENGED RESOURCE CENTER at 1-800-255-9877.

Optional Service Contract Coverage

Chrysler Service Contracts provide you with additional peace of mind protection for your new vehicle. Chrysler Motors offers a variety of plans to meet your needs. Plan coverage begins after your vehicle's basic warranty expires. A deductible applies. Allowances for car rental and towing are also included. See your dealer for details.

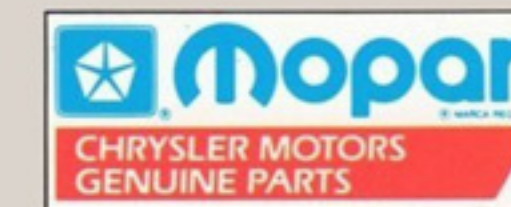

MOPAR parts are engineered by Chrysler Motors for use in your new Plymouth Acclaim. When replacement is necessary, be sure to specify MOPAR parts. Used by professional mechanics worldwide.

Consider Leasing

More consumers are considering leasing as an alternative to buying. Leasing a new Plymouth Acclaim usually involves a small security deposit and a first month's lease payment. Monthly payments are usually less than financing a new car purchase. Ask your dealer for details.



Making the best even more affordable.

Chrysler Credit offers a variety of finance programs that will help make your new Plymouth Acclaim even more affordable. These special finance and leasing programs are designed to meet the needs of today's automotive buyer. They include Gold Key Lease, America's Choice Payment Plan, College Graduate Plans, Retail Financing, and more. Ask your salesperson for details.

All product illustrations and specifications are based upon current information at the time of publication approval. Although descriptions are believed correct, accuracy cannot be guaranteed. Chrysler Motors reserves the right to make changes from time to time, without notice or obligation, in prices, specifications, colors and materials, and to change or discontinue models. See your dealer for the latest information.

Plymouth and MOPAR are registered trademarks, and Acclaim is a trademark of Chrysler Motors Corporation.

Buckle up for safety.

THE NINE MOST IMPORTANT WORDS PLYMOUTH KNOWS:

SATISFY THE CUSTOMER.[™]
SATISFY THE CUSTOMER.
SATISFY THE CUSTOMER.

